

DIGITAL PIANO

YDP-151/YDP-323

Owner's Manual Bedienungsanleitung Mode d'emploi Manual de instrucciones

IMPORTANT

Check your power supply

Make sure that your local AC mains voltage matches the voltage specified on the name plate on the bottom panel. In some areas a voltage selector may be provided on the bottom panel of the main keyboard unit near the power cord. Make sure that the voltage selector is set for the voltage in your area. The voltage selector is set at 240V when the unit is initially shipped. To change the setting use a "minus" screwdriver to rotate the selector dial so that the correct voltage appears next to the pointer on the panel.

WICHTIG

Überprüfung der Stromversorgung

Vergewissern Sie sich vor dem Anschließen an das Stromnetz, daß die örtliche Netzspannung den Betriebsspannungswerten auf dem Typenschild an der Unterseite des Instruments entspricht. In bestimmten Verkaufsgebieten ist das Instrument mit einem Spannungswähler an der Unterseite neben der Netzkabeldurchführung ausgestattet. Falls vorhanden, muß der Spannungswähler auf die örtliche Netzspannung eingestellt werden. Der Spannungswähler wurde werkseitig auf 240 V voreingestellt. Zum Verstellen drehen Sie den Spannungsregler mit einem Schlitzschraubendreher, bis der Zeiger auf den korrekten Spannungswert weist.

IMPORTANT

Contrôler la source d'alimentation

Vérifiez que la tension spécifiée sur le panneau inférieur correspond à la tension du secteur. Dans certaines régions, l'instrument peut être équipé d'un sélecteur de tension situé sur le panneau inférieur du clavier à proximité du cordon d'alimentation.

Vérifiez que ce sélecteur est bien réglé en fonction de la tension secteur de votre région. Le sélecteur de tension est réglé sur 240 V au départ d'usine. Pour modifier ce réglage, utilisez un tournevis à lame plate pour tourner le sélecteur afin de mettre l'indication correspondant à la tension de votre région vis à vis du repère triangulaire situé sur le panneau.

IMPORTANTE

Verifique la alimentación de corriente

Asegúrese de que tensión de alimentación de CA de su área corresponde con la tensión especificada en la placa de características del panel inferior. En algunas zonas puede haberse incorporado un selector de tensión en el panel inferior de la unidad del teclado principal, cerca del cable de alimentación. Asegúrese de que el selector de tensión esté ajustado a la tensión de su área. El selector de tensión se ajusta a 240V cuando la unidad sale de fábrica. Para cambiar el ajuste, emplee un destornillador de cabeza "recta" para girar el selector de modo que aparezca la tensión correcta al lado del indicador del panel.

ENGLISH

DEUTSCH

FRANÇAIS

ESPAÑOL

EN
DE
FR
ES

SPECIAL MESSAGE SECTION

PRODUCT SAFETY MARKINGS: Yamaha electronic products may have either labels similar to the graphics shown below or molded/stamped facsimiles of these graphics on the enclosure. The explanation of these graphics appears on this page. Please observe all cautions indicated on this page and those indicated in the safety instruction section.

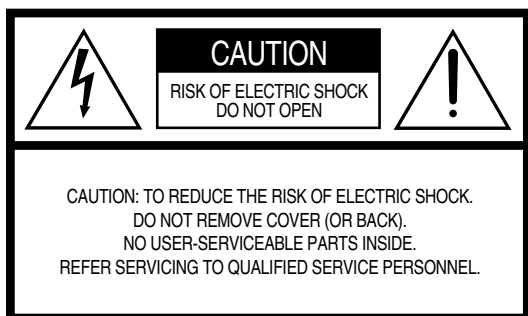

See bottom of Keyboard enclosure for graphic symbol markings.



The exclamation point within the equilateral triangle is intended to alert the user to the presence of important operating and maintenance (servicing) instructions in the literature accompanying the product.

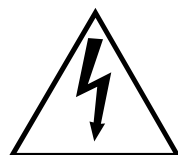

The lightning flash with arrowhead symbol, within the equilateral triangle, is intended to alert the user to the presence of uninsulated “dangerous voltage” within the product’s enclosure that may be of sufficient magnitude to constitute a risk of electrical shock.

IMPORTANT NOTICE: All Yamaha electronic products are tested and approved by an independent safety testing laboratory in order that you may be sure that when it is properly installed and used in its normal and customary manner, all foreseeable risks have been eliminated. DO NOT modify this unit or commission others to do so unless specifically authorized by Yamaha. Product performance and/or safety standards may be diminished. Claims filed under the expressed warranty may be denied if the unit is/has been modified. Implied warranties may also be affected.

SPECIFICATIONS SUBJECT TO CHANGE: The information contained in this manual is believed to be correct at the time of printing. However, Yamaha reserves the right to change or modify any of the specifications without notice or obligation to update existing units.

ENVIRONMENTAL ISSUES: Yamaha strives to produce products that are both user safe and environmentally friendly. We sincerely believe that our products and the production methods used to produce them, meet these goals. In keeping with both the letter and the spirit of the law, we want you to be aware of the following:

Battery Notice: This product MAY contain a small non-rechargeable battery which (if applicable) is soldered in place. The average life span of this type of battery is approximately five years. When replacement becomes necessary, contact a qualified service representative to perform the replacement.

Warning: Do not attempt to recharge, disassemble, or incinerate this type of battery. Keep all batteries away from children. Dispose of used batteries promptly and as regulated by applicable laws. Note: In some areas, the servicer is required by law to return the defective parts. However, you do have the option of having the servicer dispose of these parts for you.

Disposal Notice: Should this product become damaged beyond repair, or for some reason its useful life is considered to be at an end, please observe all local, state, and federal regulations that relate to the disposal of products that contain lead, batteries, plastics, etc.

NOTICE: Service charges incurred due to lack of knowledge relating to how a function or effect works (when the unit is operating as designed) are not covered by the manufacturer’s warranty, and are therefore the owners responsibility. Please study this manual carefully and consult your dealer before requesting service.

NAME PLATE LOCATION: The graphic below indicates the location of the name plate. The model number, serial number, power requirements, etc., are located on this plate. You should record the model number, serial number, and the date of purchase in the spaces provided below and retain this manual as a permanent record of your purchase.

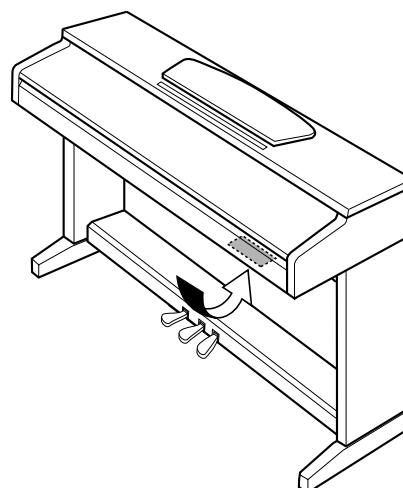

YDP-151/YDP-323

Model _____

Serial No. _____

Purchase Date _____

PRECAUTIONS

PLEASE READ CAREFULLY BEFORE PROCEEDING

* Please keep this manual in a safe place for future reference.



WARNING

Always follow the basic precautions listed below to avoid the possibility of serious injury or even death from electrical shock, short-circuiting, damages, fire or other hazards. These precautions include, but are not limited to, the following:

Power supply/Power cord

- Only use the voltage specified as correct for the instrument. The required voltage is printed on the name plate of the instrument.
- Check the electric plug periodically and remove any dirt or dust which may have accumulated on it.
- Use only the supplied power cord/plug.
- Do not place the power cord near heat sources such as heaters or radiators, and do not excessively bend or otherwise damage the cord, place heavy objects on it, or place it in a position where anyone could walk on, trip over, or roll anything over it.

Do not open

- Do not open the instrument or attempt to disassemble the internal parts or modify them in any way. The instrument contains no user-serviceable parts. If it should appear to be malfunctioning, discontinue use immediately and have it inspected by qualified Yamaha service personnel.

Water warning

- Do not expose the instrument to rain, use it near water or in damp or wet conditions, or place containers on it containing liquids which might spill into any openings.
- Never insert or remove an electric plug with wet hands.

Fire warning

- Do not put burning items, such as candles, on the unit. A burning item may fall over and cause a fire.

If you notice any abnormality

- If the power cord or plug becomes frayed or damaged, or if there is a sudden loss of sound during use of the instrument, or if any unusual smells or smoke should appear to be caused by it, immediately turn off the power switch, disconnect the electric plug from the outlet, and have the instrument inspected by qualified Yamaha service personnel.



CAUTION

Always follow the basic precautions listed below to avoid the possibility of physical injury to you or others, or damage to the instrument or other property. These precautions include, but are not limited to, the following:

Power supply/Power cord

- When removing the electric plug from the instrument or an outlet, always hold the plug itself and not the cord. Pulling by the cord can damage it.
- Remove the electric plug from the outlet when the instrument is not to be used for extended periods of time, or during electrical storms.
- Do not connect the instrument to an electrical outlet using a multiple-connector. Doing so can result in lower sound quality, or possibly cause overheating in the outlet.

Assembly

- Read carefully the attached documentation explaining the assembly process. Failure to assemble the instrument in the proper sequence might result in damage to the instrument or even injury.

Location

- Do not expose the instrument to excessive dust or vibrations, or extreme cold or heat (such as in direct sunlight, near a heater, or in a car during the day) to prevent the possibility of panel disfiguration or damage to the internal components.
- Do not use the instrument in the vicinity of a TV, radio, stereo equipment, mobile phone, or other electric devices. Otherwise, the instrument, TV, or radio may generate noise.
- Do not place the instrument in an unstable position where it might accidentally fall over.
- Before moving the instrument, remove all connected cables.
- When setting up the instrument, make sure that the AC outlet you are using is easily accessible. If some trouble or malfunction occurs, immediately turn off the power switch and disconnect the plug from the outlet.

Connections

- Before connecting the instrument to other electronic components, turn off the power for all components. Before turning the power on or off for all components, set all volume levels to minimum. Also, be sure to set the volumes of all components at their minimum levels and gradually raise the volume controls while playing the instrument to set the desired listening level.

Maintenance

- When cleaning the instrument, use a soft, dry or slightly damp cloth. Do not use paint thinners, solvents, cleaning fluids, or chemical-impregnated wiping cloths.

Handling caution

- Take care that the key cover does not pinch your fingers, and do not insert a finger or hand in any gaps on the key cover or instrument.
- Never insert or drop paper, metallic, or other objects into the gaps on the key cover, panel or keyboard. If this happens, turn off the power immediately and unplug the power cord from the AC outlet. Then have the instrument inspected by qualified Yamaha service personnel.
- Do not place vinyl, plastic or rubber objects on the instrument, since this might discolor the panel or keyboard.
- Do not rest your weight on, or place heavy objects on the instrument, and do not use excessive force on the buttons, switches or connectors.
- Do not operate the instrument for a long period of time at a high or uncomfortable volume level, since this can cause permanent hearing loss. If you experience any hearing loss or ringing in the ears, consult a physician.

Using the bench (If included)

- Do not place the bench in an unstable position where it might accidentally fall over.
- Do not play carelessly with or stand on the bench. Using it as a tool or step-ladder or for any other purpose might result in accident or injury.
- Only one person should sit on the bench at a time, in order to prevent the possibility of accident or injury.
- If the bench screws become loose due to extensive long-term use, tighten them periodically using the included tool.

Saving data

Saving and backing up your data

- Data in the instrument's internal memory can be lost due to operational errors or malfunction. Be sure to save any important data to external media via a computer connected to the instrument. (page 31)

Yamaha cannot be held responsible for damage caused by improper use or modifications to the instrument, or data that is lost or destroyed.

Always turn the power off when the instrument is not in use.

Welcome

Thank you for purchasing the Yamaha Digital Piano! We recommend that you read this manual carefully so that you can take full advantage of the advanced and convenient functions of your new digital piano.

We also recommend that you keep this manual in a safe, convenient place for future reference.

About this Owner's Manual

This manual consists of three main sections: "Introduction," "Reference" and "Appendix."

■ Introduction (page 2):

Please read this section first.

■ Reference (page 13):

This section explains how to make detailed settings for the instrument's various functions.

■ Appendix (page 39):

This section introduces reference material.

- * The illustrations as shown in this owner's manual are for instructional purposes only, and may be different from the ones on your instrument.

COPYRIGHT NOTICE

This product incorporates and bundles computer programs and contents in which Yamaha owns copyrights or with respect to which it has license to use others' copyrights. Such copyrighted materials include, without limitation, all computer software, MIDI files and WAVE data. Any unauthorized use of such programs and contents outside of personal use is not permitted under relevant laws. Any violation of copyright has legal consequences. **DON'T MAKE, DISTRIBUTE OR USE ILLEGAL COPIES.**

Copying of the commercially available software is strictly prohibited except for your personal use.

Trademarks:

- Apple and Macintosh are trademarks of Apple Computer, Inc.
- Windows is a registered trademark of Microsoft® Corporation.
- All other trademarks are the property of their respective holders.

Table of Contents

Introduction

SPECIAL MESSAGE SECTION	2
PRECAUTIONS	3
About this Owner's Manual	5
Application Index	7
Accessories	8
Maintenance	8
Features	9
Before Using the Digital Piano	10
Key Cover	10
Music Rest	10
Turning the Power On.....	11
Setting the Volume.....	12
Using Headphones.....	12

Reference

Part Names	14
Listening to the Demo Songs	15
Listening to 50 Piano Preset Songs	16
Listening to Songs Loaded from the Computer	17
Selecting & Playing Voices	18
Selecting Voices.....	18
Using the Pedals	19
Adding Variations to the Sound – Reverb.....	20
Layering Two Voices (Dual mode)	21
Transposition	22
Fine-tuning the Pitch	22
Using the Metronome.....	23
Adjusting the Keyboard Touch (Touch Sensitivity)	24
Recording your Performance	25
Playing Back Recorded Performance Data	26
Connecting MIDI Instruments	27
About MIDI.....	27
MIDI's Capability.....	27
Connecting the Digital Piano to a Computer	28
MIDI Functions	29
MIDI Transmit/Receive Channel Selection.....	29
Local Control ON/OFF.....	29
Program Change ON/OFF.....	30
Control Change ON/OFF	30

Transmitting Song Data between the Computer and the Digital Piano	31
Loading Song Data from a Computer to the Digital Piano	31
Transmitting Song Data from the Digital Piano to a Computer	31
Backing up Data and Initializing the Settings ..	32
Troubleshooting	33
Options	33
Keyboard Stand Assembly	34
Index	37

Appendix

MIDI Data Format	40
MIDI Implementation Chart	44
Specifications	45

Application Index

Use this index to find reference pages that may be helpful for your particular application and situation.

Listening

- Listening to demo songs with different voices..... “Listening to the Demo Songs” on page 15
- Listening to songs from “50 Greats for the Piano” “Listening to 50 Piano Preset Songs” on page 16
- Listening to recorded performances..... “Playing Back Recorded Performance Data” on page 26
- Listening to songs loaded from the computer “Listening to Songs Loaded from the Computer” on page 17

Playing

- Using three pedals “Using the Pedals” on page 19
- Shifting the pitch of the keyboard up or down in semitone steps “Transposition” on page 22
- Fine-tuning the pitch of the entire instrument when you play this instrument
along with other instruments or CD music..... “Fine-tuning the Pitch” on page 22
- Adjusting the key touch response (sensitivity) for changing the volume
..... “Adjusting the Keyboard Touch (Touch Sensitivity)” on page 24

Changing voices

- Viewing the list of voices..... “Selecting Voices” on page 18
- Simulating a concert hall “Adding Variations to the Sound – Reverb” on page 20
- Combining two voices..... “Layering Two Voices (Dual mode)” on page 21

Practicing

- Practicing with an accurate and steady tempo “Using the Metronome” on page 23

Recording

- Recording your performances “Recording your Performance” on page 25

Connecting this instrument to other devices

- What is MIDI? “Connecting MIDI Instruments” on page 27
- Connecting the computer “Connecting the Digital Piano to a Computer” on page 28
- Transmitting the recording of your performance to a computer
..... “Transmitting Song Data from the Digital Piano to a Computer” on page 31
- Transmitting song data from a computer to the instrument
..... “Loading Song Data from a Computer to the Digital Piano” on page 31

Assembling

- Assembling and disassembling this instrument..... “Keyboard Stand Assembly” on pages 34–36

Accessories

- “50 Greats for the Piano” (Music Book)
- Owner’s Manual
This manual contains complete instructions for operating your digital piano.
- Quick Guide
- Headphone hanger set
- Assembly parts

Maintenance

Clean the instrument using a dry or slightly damp soft cloth (wring well).

 **CAUTION**

Do not use benzene, thinner, detergent, or chemically-treated cloth for cleaning. Do not place vinyl, plastic or rubber products on the instrument.

Otherwise, the panel or keys may become discolored or degraded.

 **CAUTION**

Before using this instrument, be sure to read “Precautions” on pages 3 – 4.

■ **Tuning**

Unlike an acoustic piano, this instrument does not need to be tuned. It always stays perfectly in tune.

■ **Transporting**

If you move to another location, you can transport this instrument along with your other belongings. You can move the unit as it is (assembled) or you can disassemble the unit before moving.

Transport the keyboard horizontally. Do not lean it up against a wall or stand it up on its side. Do not subject the instrument to excessive vibration or shock.

Features

The Yamaha digital piano offers unmatched sonic realism and natural grand-piano type playability as well as Yamaha's original "AWM Stereo Sampling" tone-generation technology for rich, musical voices, and a special "Graded Hammer" keyboard that provides graded key weight and response throughout the keyboard range.

Two of the piano voices, "Grand Piano 1" and "Grand Piano 2," feature totally new samples recorded from a full-size concert grand piano. The "Electric Piano 1" voice features multiple samples for different velocities (Dynamic Sampling); that is, different samples are used depending on how fast or strong you strike the keys.

This digital piano sounds much closer to a true acoustic piano.

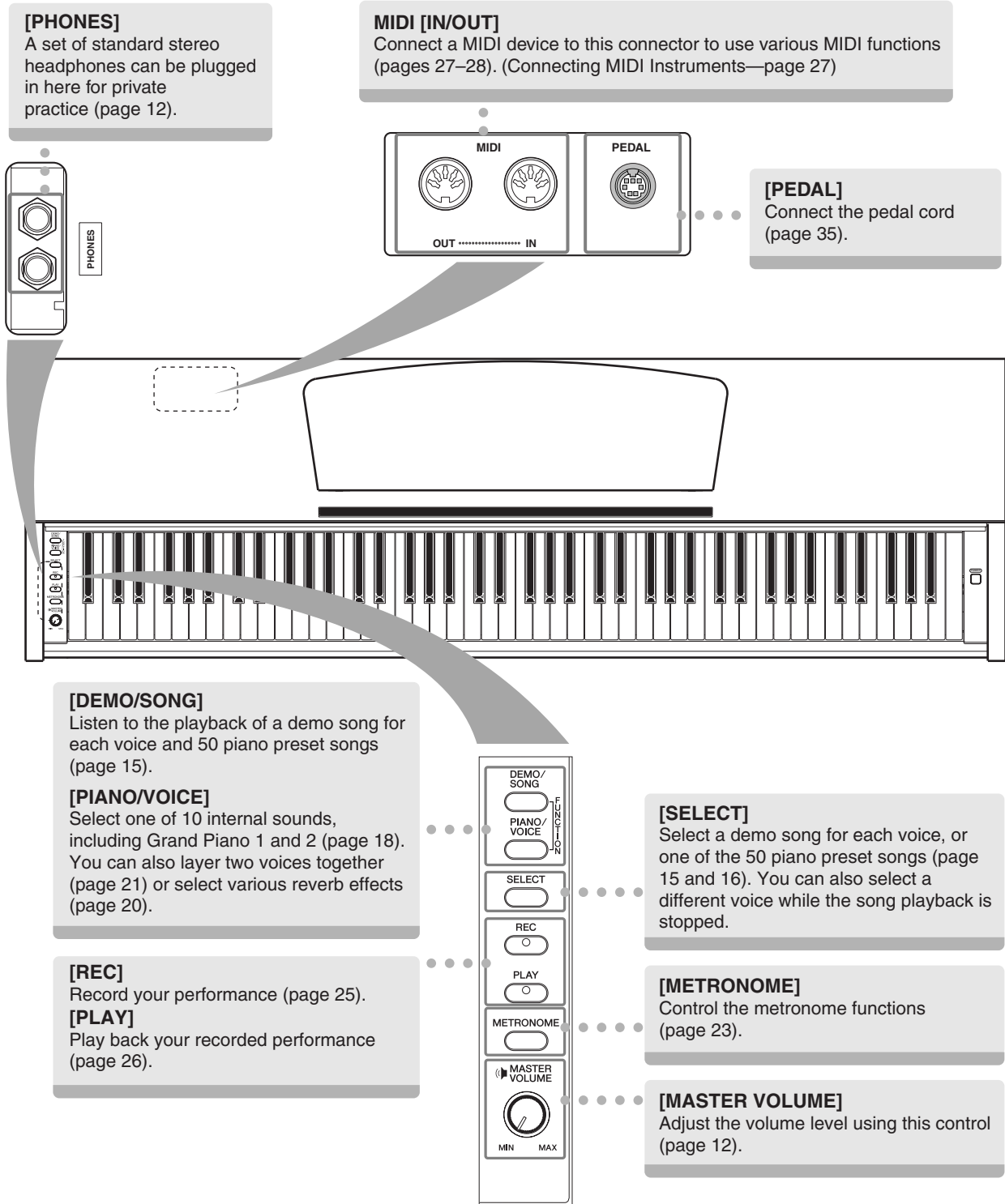

Before Using the Digital Piano

Key Cover

To open the key cover:

Lift the cover slightly, then push and slide it open.

To close the key cover:

Slide the cover toward you and gently lower the cover over the keys.

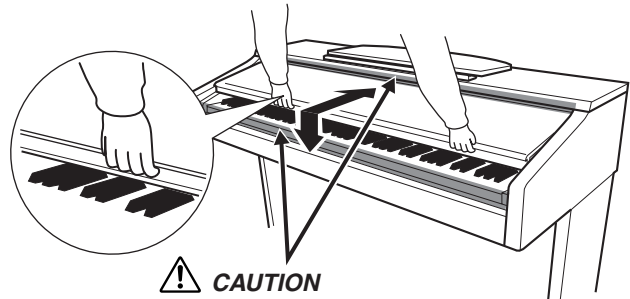

⚠ CAUTION

Be careful to avoid catching your fingers when opening or closing the cover.

⚠ CAUTION

Hold the cover with both hands when opening or closing it. Do not release it until it is fully opened or closed. Be careful to avoid catching fingers (yours or others, especially children's) between the cover and main unit.

⚠ CAUTION

Do not place objects, such as a piece of metal or paper, on top of the key cover. Small objects placed on the key cover may fall inside the unit when the cover is opened and may be nearly impossible to remove. This could cause electric shock, short circuit, fire or other serious damage to the instrument.

Music Rest

To raise the music rest:

1. Pull the music rest up and toward yourself as far as it will go.
2. Flip down the two metal supports at the left and right on the rear of the music rest.
3. Lower the music rest so that it rests on the metal supports.

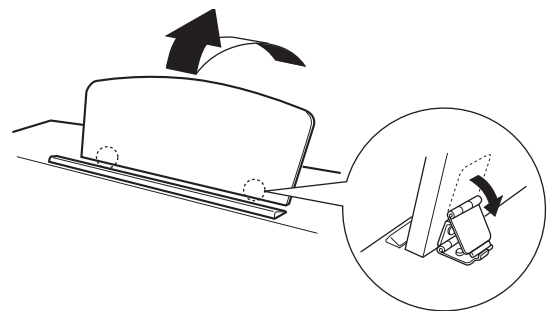

To lower the music rest:

1. Pull the music rest toward yourself as far as it will go.
2. Raise the two metal supports (at the rear of the music rest).
3. Gently lower the music rest backward until it is all the way down.

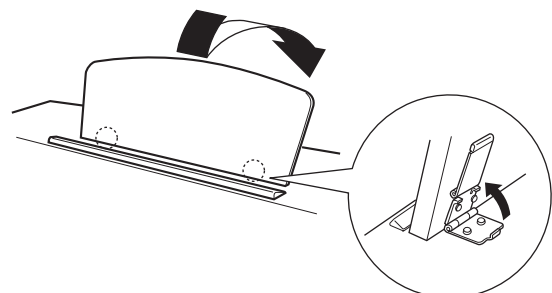

⚠ CAUTION

Do not try to use the music rest in a half-raised position. When lowering the music rest, do not release your hands from the music rest until it is all the way down.

Turning the Power On

1. Connect the power cord.

Insert the plugs at the ends of the cord: one into the AC INLET on this instrument, and the other into a standard AC outlet.

In some areas, a plug adaptor may be provided to match the pin configuration of AC wall outlets in your area.

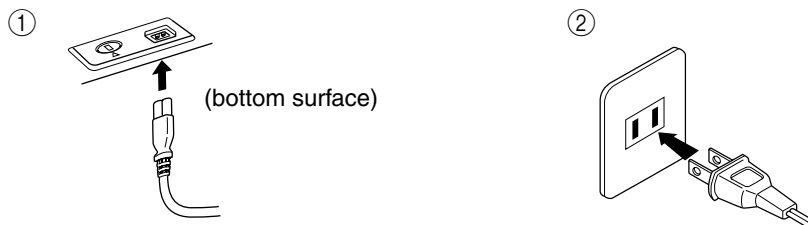

(The shape of the plug differs depending on locale.)

CAUTION

Make sure your digital piano is rated for the AC voltage supplied in the area in which the piano will be used. (The voltage rating appears on the name plate on the bottom panel). In some areas, a voltage selector may be provided on the bottom panel of the main keyboard unit near the power cord. Make sure that the voltage selector is set for the voltage in your area. Connecting the unit to an inappropriate AC supply can seriously damage the internal circuitry and may even pose a shock hazard!

Use only the AC power cord supplied with the instrument. If the supplied power cord is lost or damaged and needs to be replaced, contact your Yamaha dealer. The use of an inappropriate replacement can pose a fire and shock hazard!

The type of AC power cord provided with the instrument may be different depending on the country in which the instrument was purchased. (In some areas a plug adaptor may be provided to match the pin configuration of the AC wall outlets in your area.)

Do NOT modify the plug provided with the instrument. If the plug will not fit the outlet, have a proper outlet installed by a qualified electrician.

2. Turn the power on.

Press the **[POWER]** button.

- The power indicator located below the left end of the keyboard lights up.

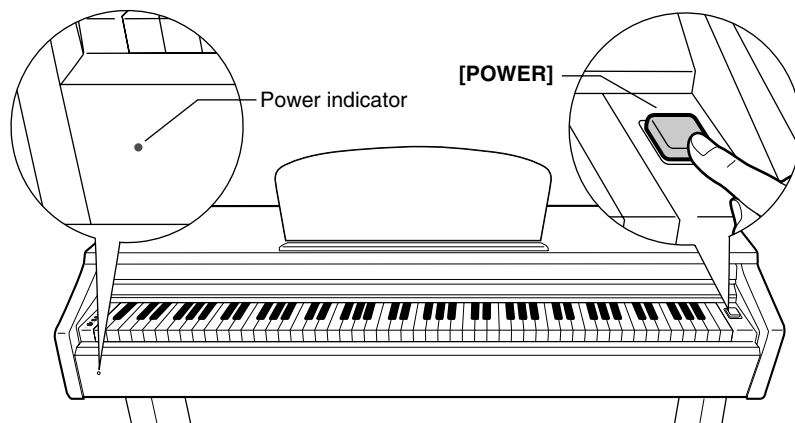

To turn the power off, press the **[POWER]** button again.

- The power indicator turns off.

Power indicator

If you forget to turn off the power to the piano and close the key cover, the power indicator will remain lit, indicating that the power is still on.

Setting the Volume

When you start playing, adjust the [MASTER VOLUME] control to the most comfortable listening level.

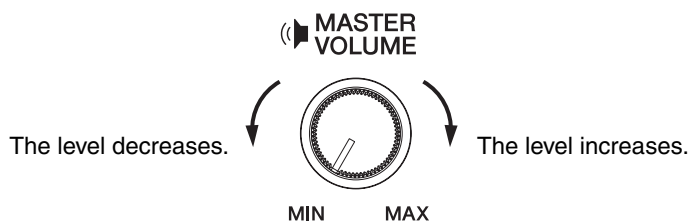

CAUTION

Do not use this instrument at a high volume level for a long period of time, or your hearing may be damaged.

Using Headphones

Connect a pair of headphones to one of the [PHONES] jacks.

Two [PHONES] jacks are provided.

You can connect two sets of standard stereo headphones. (If you are using only one pair of headphones, you can plug them into either jack.)

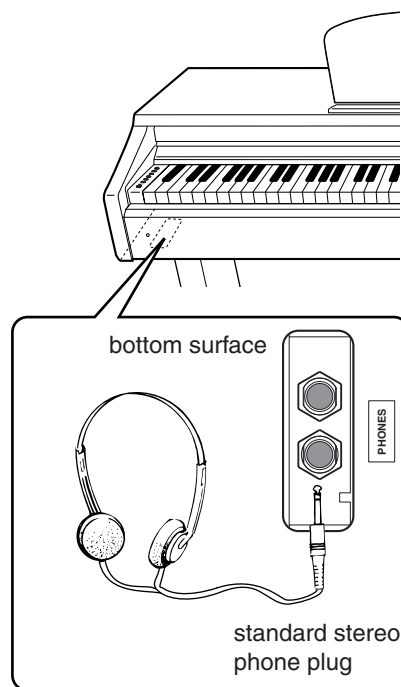

Using the Headphone Hanger

A headphone hanger is included in the package so that you can hang the headphones on this instrument. Install the headphone hanger using the included two screws (4 × 10mm) as shown in the figure.

CAUTION

Do not hang anything other than the headphones on the hanger. Otherwise, this instrument or the hanger may be damaged.

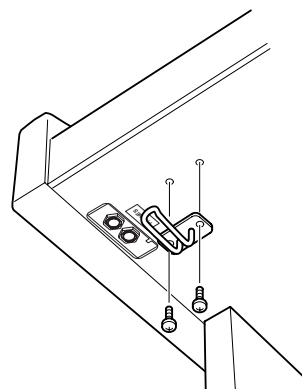

Reference

This section explains how to make detailed settings for this instrument's various functions.

Part Names.....	14	Keyboard Stand Assembly	34
Listening to the Demo Songs.....	15	Index.....	37
Listening to 50 Piano Preset Songs.....	16		
Listening to Songs Loaded from the Computer	17		
Selecting & Playing Voices	18		
Selecting Voices	18		
Using the Pedals	19		
Adding Variations to the Sound – Reverb.....	20		
Layering Two Voices (Dual mode)	21		
Transposition.....	22		
Fine-tuning the Pitch	22		
Using the Metronome	23		
Adjusting the Keyboard Touch (Touch Sensitivity) ..	24		
Recording your Performance	25		
Playing Back Recorded Performance Data	26		
Connecting MIDI Instruments	27		
About MIDI.....	27		
MIDI's Capability.....	27		
Connecting the Digital Piano to a Computer	28		
MIDI Functions.....	29		
MIDI Transmit/Receive Channel Selection	29		
Local Control ON/OFF.....	29		
Program Change ON/OFF	30		
Control Change ON/OFF	30		
Transmitting Song Data between the Computer and the Digital Piano.....	31		
Loading Song Data from a Computer to the Digital Piano	31		
Transmitting Song Data from the Digital Piano to a Computer	31		
Backing up Data and Initializing the Settings	32		
Troubleshooting	33		
Options	33		

Part Names

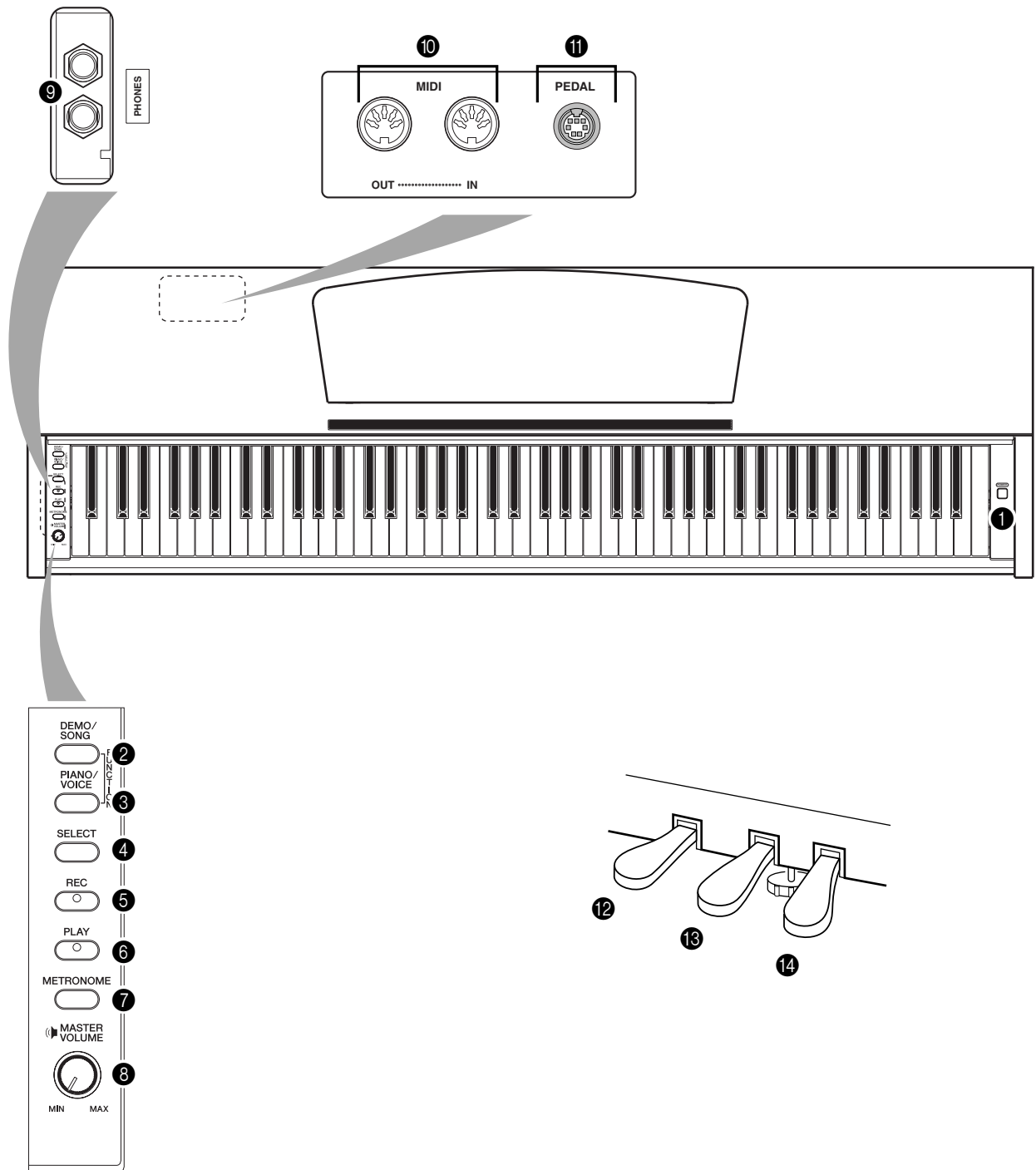

- ① [POWER] P11
- ② [DEMO/SONG] P15
- ③ [PIANO/VOICE] P18–21
- ④ [SELECT] P15, 16, 18
- ⑤ [REC] P25
- ⑥ [PLAY] P25, 26
- ⑦ [METRONOME] P23

- ⑧ [MASTER VOLUME] P12
- ⑨ [PHONES] P12
- ⑩ MIDI [IN] [OUT] P27
- ⑪ [PEDAL] P35
- ⑫ Soft (Left) Pedal P19
- ⑬ Sostenute (Center) Pedal P19
- ⑭ Damper (Right) Pedal P19

Listening to the Demo Songs

Demo songs are provided that effectively demonstrate each of this instrument's voices.

Procedure

1. Turn on the power.

(In case the power is not turned ON) Press the **[POWER]** button.

When you start playing, adjust the **[MASTER VOLUME]** control to the most comfortable listening level.

2. Start playing back a demo song.

Press the **[DEMO/SONG]** button.

⇒ The demo song for the currently-selected voice starts playing.

3. Select and play a demo song.

While a demo song is playing, press the **[SELECT]** button to select and play the next demo song.

If you wish to select a particular demo song from 10 voice demo songs, while holding down the **[DEMO/SONG]** button, press one of the C1–A1 keys.

⇒ The selected demo song starts to play. Starting with the selected song, the playback of the demo songs will continue in the following sequence: other voice demo songs, followed by 50 piano preset songs, and any songs loaded from the computer. The sequence then returns to the first demo song and repeats until you stop it.

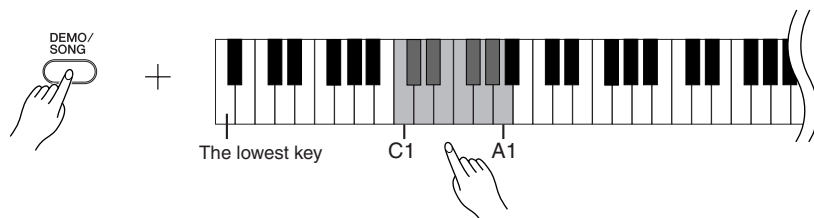

Demo Songs

Each of the 10 voices features its own demo song that showcases the corresponding voice. Please refer to “Selecting Voices” on page 18.

The demo songs listed below are re-arranged excerpts from the original compositions.

The other demo songs are Yamaha's original pieces (©2005 Yamaha Corporation).

Key	Voice Name	Title	Composer
C1	GrandPiano1	“Eintritt” Waldszenen Op.82	R. Schumann
E1	Harpsichord1	Gavotte	J.S. Bach
F1	Harpsichord2	Invention No.1	J.S. Bach

Adjusting the Volume

Use the **[MASTER VOLUME]** control to adjust the volume.

4. Stop the Voice demo.

Press the **[DEMO/SONG]** button to stop playback.

Refer to the voice list on page 18 for more information on the characteristics of each preset voice.

You cannot adjust the tempo of demo songs.

The demo songs will not be transmitted via MIDI.

Listening to 50 Piano Preset Songs

This digital piano provides performance data for 50 piano songs as well as voice demo songs. You can simply listen to these songs. You can also refer to the included "50 Greats for the Piano" that contains scores for 50 piano preset songs.

Procedure

1. Select and play back a piano preset song.

The number of each piano preset song is assigned to the C2-C#6 keys.

While holding down the [DEMO/SONG] button, press one of the C2-C#6 keys to select a song to play back.

⇒ The selected piano song starts to play.

To play all preset songs consecutively in sequence, while holding down the [DEMO/SONG] button, press the D6 key.

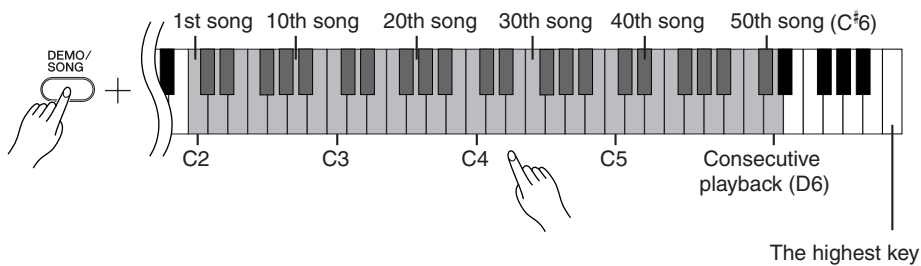

Press the [SELECT] button to change to the next piano song.

Adjusting the Volume

Use the [MASTER VOLUME] control to adjust the volume.

2. Stop playback.

To stop the song during playback (or continuous playback), press the [DEMO/SONG] button.

- To continue playing other songs, see procedure 1 above.

Song:

On this instrument, performance data is called a "Song." This includes demo songs and 50 piano preset tunes.

You can play the keyboard along with the preset song. You can change the voice playing on the keyboard.

The default tempo is automatically selected whenever a new preset song is selected, and when a new preset song begins playback.

To adjust the tempo of the preset song playback, see page 23.

When you select a different song (or a different song is selected during chained playback), an appropriate reverb type will be selected accordingly.

The 50 piano preset songs will not be transmitted via MIDI.

Listening to Songs Loaded from the Computer

You can transfer song data from your computer to this instrument and play back the songs. (See page 31 for more information on loading song data from the computer.)

Procedure

1. Select and play back a song.

Song numbers (1 through 10) are assigned to the D#6-C7 keys (see the illustration below).

While holding down the [DEMO/SONG] button, press one of the D#6-C7 keys to select a song to play back.

⇒ The selected song starts to play.

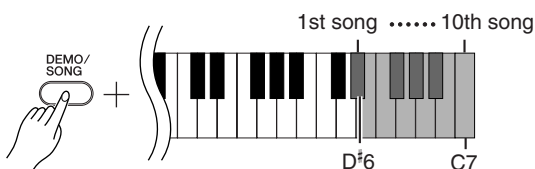

Adjusting the Volume

Use the [MASTER VOLUME] control to adjust the volume while listening to the song.

2. Stop playback.

Playback will stop automatically when the selected song has finished. To stop the song during playback, press the [DEMO/SONG] button.

Selecting a Song Playback Channel

If a song loaded from the computer uses a voice that is not supported by this instrument, the originally-assigned voice may not be reproduced accurately. In this case, switching the song playback channel from “All” to “1 + 2” may improve the tone to more natural sound.

Selecting all song playback channels:

While pressing and holding down the [DEMO/SONG] button and the [PIANO/VOICE] button simultaneously, press the B6 key.

⇒ All channels 1 through 16 will produce the sound.

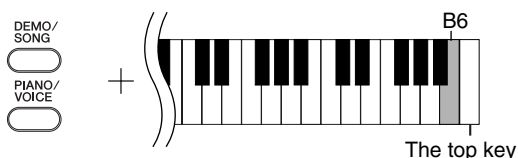

Selecting 1 + 2 song playback channels:

While pressing and holding down the [DEMO/SONG] button and the [PIANO/VOICE] button simultaneously, press the C7 key.

⇒ Channels 1 + 2 will produce the sound.

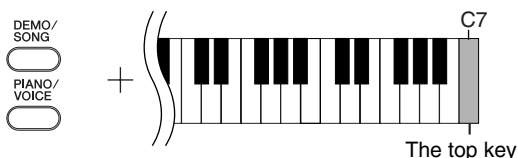

You can load up to 10 songs or up to 352 KB of data from the computer.

Use the following table to write down the song titles you loaded from the computer.

Key	Song title
D#6	
E6	
F6	
F#6	
G6	
G#6	
A6	
A#6	
B6	
C7	

Selecting & Playing Voices

Selecting Voices

Procedure

Press and release the **[PIANO/VOICE]** button to select the Grand Piano 1 voice.

While holding down the **[PIANO/VOICE]** button, press one of the C1-A1 keys to select a voice. Alternatively, you can press the **[PIANO/VOICE]** button, then press the **[SELECT]** button repeatedly to select a different voice.

Turn the **[MASTER VOLUME]** control to adjust the volume level while playing the keyboard.

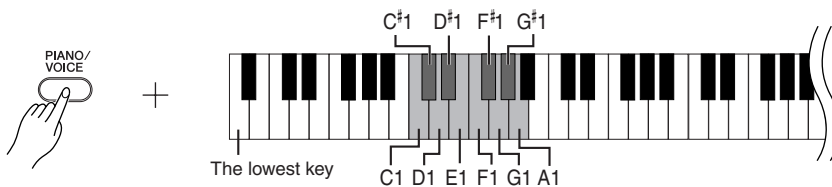

To understand the characteristics of various voices, listen to demo songs for each voice (page 15).

Voice:

On this instrument, a voice means a "tone" or "tonal color."

Selecting a voice automatically engages the best-suited reverb type and depth (page 20) for that particular voice.

Key	Voice Name	Description
C1	Grand Piano 1	Recorded samples from a full concert grand piano. Perfect for classical compositions as well as any other style that requires acoustic piano.
C#1	Grand Piano 2	Spacious and clear piano with bright reverb. Good for popular music.
D1	E.Piano 1	An electronic piano sound created by FM synthesis. Good for popular music.
D#1	E.Piano 2	The sound of an electric piano using hammer-struck metallic "tines." Soft tone when played lightly, and an aggressive tone when played hard.
E1	Harpsichord 1	The definitive instrument for baroque music. Since the strings of a harpsichord are plucked, there is no touch response.
F1	Harpsichord 2	Mixes the same voice an octave higher for a more brilliant tone.
F#1	Vibraphone	The sound of a vibraphone played with relatively soft mallets.
G1	Church Organ 1	This is a typical pipe organ sound (8 feet + 4 feet + 2 feet). Good for sacred music from the Baroque period.
G#1	Church Organ 2	This is the organ's full coupler sound, often associated with Bach's "Toccatina and Fugue".
A1	Strings	Spacious and large-scale string ensemble. Try combining this voice with piano in DUAL mode.

Using the Pedals

Damper (Right) Pedal

The damper pedal functions in the same way as a damper pedal on an acoustic piano. When the damper pedal is pressed, notes sustain longer. Releasing the pedal immediately stops (damps) any sustained notes.

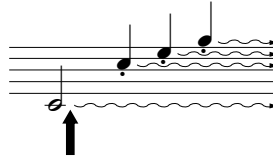

When you press the damper pedal here, the notes you play before you release the pedal sustain longer.

Sostenuto (Center) Pedal

If you play a note or chord on the keyboard and press the sostenuto pedal while the note(s) are held, those notes will sustain as long as you hold the pedal (as if the damper pedal had been pressed) but all subsequently played notes will not be sustained. This makes it possible to sustain a chord, for example, while other notes are played “staccato.”

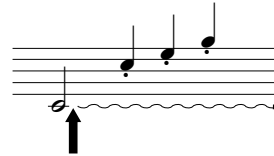

When you press the sostenuto pedal here while holding the note, the note will sustain as long as you hold the pedal.

Soft (Left) Pedal

The soft pedal reduces the volume and slightly changes the timbre of notes played while the pedal is pressed. The soft pedal will not affect notes that are already playing when it is pressed.

If the damper pedal doesn't work, make sure that the pedal cord is properly plugged into the main unit (page 35).

Organ and string voices will continue to sound for as long as the sostenuto pedal is depressed.

Adding Variations to the Sound – Reverb

This control enables you to select various digital reverb effects that add extra depth and expression to the sound to create a realistic acoustic ambience.

Procedure

While holding down the **[PIANO/VOICE]** button, press one of the C2–E2 keys to select a reverb type.

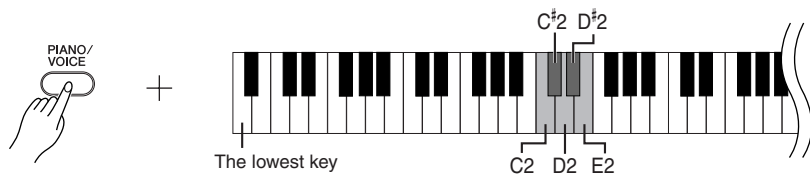

Key	Reverb Type	Description
C2	Room	This setting adds a continuous reverb effect to the sound, similar to the acoustic reverberation you would hear in a room.
C#2	Hall1	For a “bigger” reverb sound, use the HALL 1 setting. This effect simulates the natural reverberation of a small-size concert hall.
D2	Hall2	For a truly spacious reverb sound, use the HALL 2 setting. This effect simulates the natural reverberation of a large concert hall.
D#2	Stage	Simulates the reverb of a stage environment.
E2	Off	No effect is applied.

Adjusting Reverb Depth

Adjust the reverb depth for the selected voice by pressing one of the C3–G#4 keys while holding down the **[PIANO/VOICE]** button. The depth range is from 0 through 20.

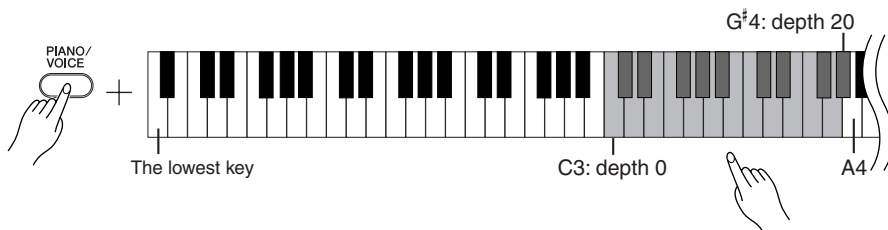

The depth value increases as you press higher keys.

While holding down the **[PIANO/VOICE]** button, press the A4 key to set the reverb to the depth most suitable for the selected voice.

The default reverb type (including OFF) and depth settings are different for each voice.

depth 0: no effect
depth 20: maximum reverb depth

Layering Two Voices (Dual mode)

You can layer two voices and play them simultaneously to create a thicker and more supple sound.

Procedure

1. Engage Dual mode.

While holding down the [PIANO/VOICE] button, press two keys in the range of C1 through A1 simultaneously to select the two desired voices. Alternatively, while holding down the [PIANO/VOICE] button, press and hold down one key, then press another. Refer to “Selecting & Playing Voices” on page 18 for information on the voices that are assigned to the keys.

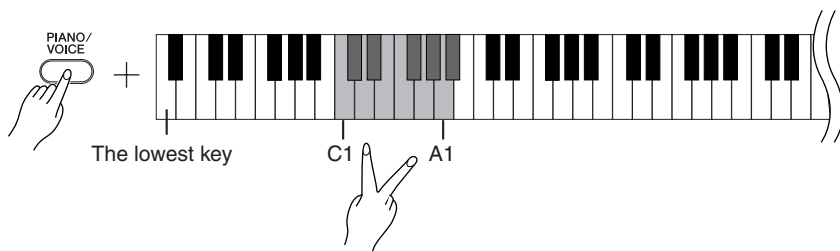

The voice assigned to the lower key will be designated as Voice 1, and the voice assigned to the higher key will be designated as Voice 2.

You can make the following settings for Voices 1 and 2 in Dual mode:

Setting the Octave

You can shift the pitch up and down in octave steps for Voice 1 and Voice 2 independently. Depending on which voices you combine in Dual mode, the combination may sound better if one of the voices is shifted up or down an octave.

While holding down the [PIANO/VOICE] button, press one of the C5–F5 keys.

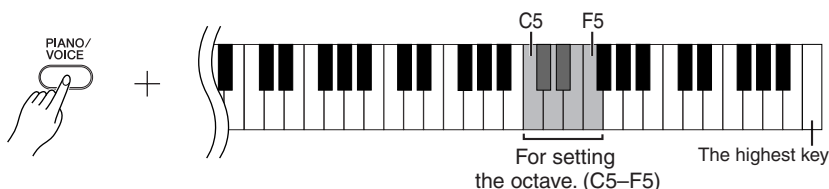

C5 key: -1 (Voice 1), C#5 key: 0 (Voice 1), D5 key: +1 (Voice 1),
 D#5 key: -1 (Voice 2), E5 key: 0 (Voice 2), F5 key: +1 (Voice 2)

Setting the Balance

You can adjust the volume balance between two voices. For example, you can set one voice as the main voice with a louder setting, and make the other voice softer. While holding down the [PIANO/VOICE] button, press one of the F#5–F#6 keys. A setting of “0” produces an equal balance between the two Dual mode voices. Settings below “0” increases the volume of Voice 2 in relation to Voice 1, and settings above “0” increases the volume of Voice 1 in relation to Voice 2.

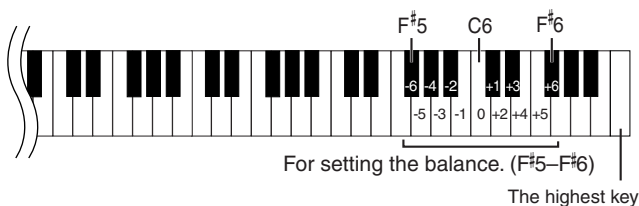

2. Exit Dual mode and return to normal play mode.

While holding down the [PIANO/VOICE] button, press one of the C1–A1 keys.

You cannot assign the same voice to Voice 1 and Voice 2 simultaneously in Dual mode.

Reverb in Dual Mode

The reverb type assigned to Voice 1 will take priority. (If the reverb assigned to Voice 1 is set to OFF, the reverb assigned to Voice 2 will be in effect.) The reverb depth setting (page 20) will be applied only to Voice 1.

Transposition

Your digital piano's Transpose function makes it possible to shift the pitch of the entire keyboard up or down in semitone intervals up to a maximum of six semitones, and lets you easily match the pitch of the keyboard to the range of a singer or other instruments.

For example, if you set the transposition amount to "5," playing key C produces pitch F. In this way, you can play a song as though it were in C major, and this instrument will transpose it to the key of F.

Procedure

While holding down the [DEMO/SONG] and [PIANO/VOICE] buttons, press one of the F#2–F#3 keys to set the desired amount of transposition.

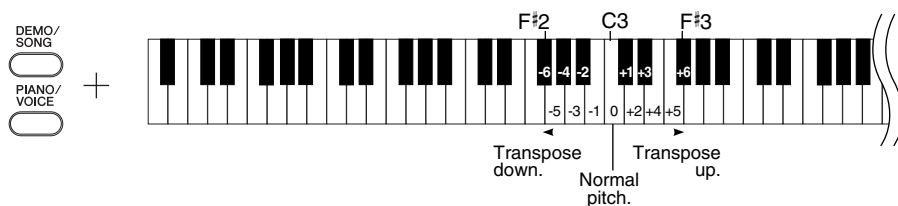

Transpose:

Changing the key signature. On this instrument, transposing shifts the pitch of the entire keyboard.

[DEMO/SONG] + [PIANO/VOICE] + C3 key: Plays normal keyboard pitch.

[DEMO/SONG] + [PIANO/VOICE] + B2 key (white key to the left of C3):

Transposes the pitch down by one semitone.

[DEMO/SONG] + [PIANO/VOICE] + B^b2 key (the first black key to the left of C3):

Transposes the pitch down a whole tone (two semitones).

[DEMO/SONG] + [PIANO/VOICE] + F#2 key:

Transposes the pitch down by six semitones.

[DEMO/SONG] + [PIANO/VOICE] + C#3 key (black key to the right of C3):

Transposes the pitch up by one semitone.

[DEMO/SONG] + [PIANO/VOICE] + D3 key (the first white key to the right of C3):

Transposes the pitch up a whole tone (two semitones).

[DEMO/SONG] + [PIANO/VOICE] + F#3 key: Transposes the pitch up by six semitones.

Fine-tuning the Pitch

You can fine-tune the pitch of the entire instrument. This function is useful when you play the digital piano along with other instruments or CD music.

Procedure

To tune up (in about 0.2Hz steps):

Hold down the A-1 and B-1 keys simultaneously and press any key between C3 and B3.

To tune down (in about 0.2Hz steps):

Hold down the A-1 and A#-1 keys simultaneously and press any key between C3 and B3.

To restore standard pitch:

Hold down the A-1, A#-1 and B-1 simultaneously and press any key between C3 and B3.

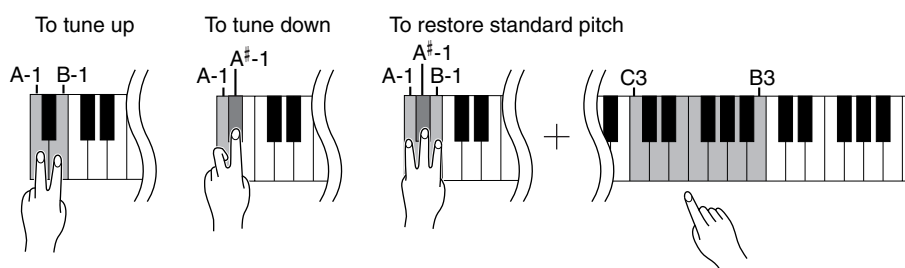

Hz (Hertz):

This unit of measurement refers to the frequency of a sound and represents the number of times a sound wave vibrates in a second.

Setting range: 427.0-453.0 Hz

Standard pitch: 440.0 Hz

Using the Metronome

Your digital piano features a built-in metronome (a device that keeps an accurate tempo) that is convenient for practicing.

Procedure

1. Start the metronome.

Press the [METRONOME] button to turn on the metronome.

Determines the Time Signature

While holding down the [METRONOME] button, press one of the C3–F3 keys.

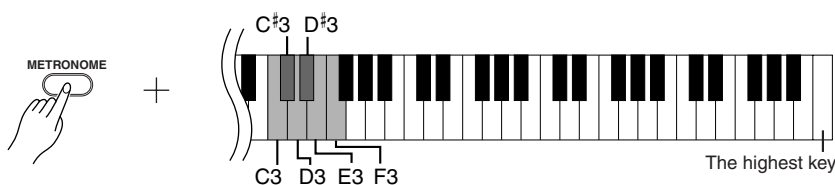

C3 key: No downbeat, C[#]3 key: 2/4, D3 key: 3/4, D[#]3 key: 4/4, E3 key: 5/4, F3 key: 6/4

Adjusting the Tempo

The tempo of the metronome and preset song playback can be set from 32 to 280 beats per minute.

A number is assigned to each of the following keys.

While holding down the [METRONOME] button, press a sequence of C4–A4 keys to specify a three-digit number.

Select a number starting from the left-most digit. For example, to set the tempo “95,” press the C4 (0), A4 (9) and F4 (5) keys in sequence.

Increasing the tempo value in steps of one:

While holding down the [METRONOME] button, press the C[#]5 key.

Decreasing the tempo value in steps of one:

While holding down the [METRONOME] button, press the B4 key.

Increasing the tempo value in steps of ten:

While holding down the [METRONOME] button, press the D5 key.

Decreasing the tempo value in steps of ten:

While holding down the [METRONOME] button, press the A[#]4 key.

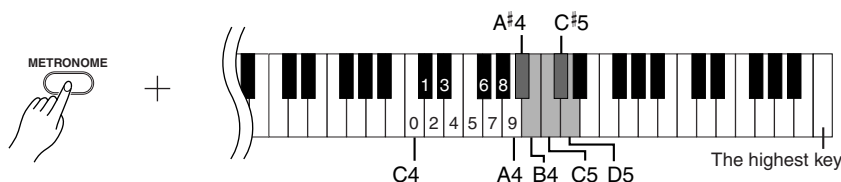

Resetting the tempo to default:

While holding down the [METRONOME] button, press the C5 key.

Adjusting the Volume

You can change the volume of the metronome sound.

While holding down the **[METRONOME]** button, press one of the C1–G2 keys to determine the volume.

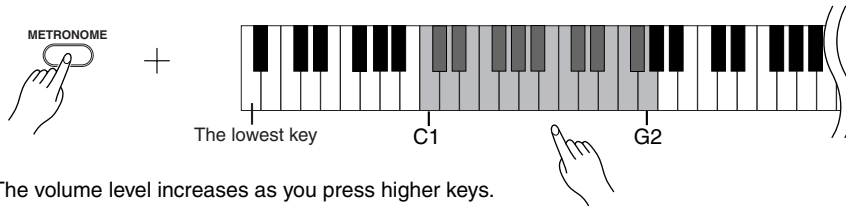

The volume level increases as you press higher keys.

2. Stop the metronome.

Turn off the metronome by pressing the **[METRONOME]** button.

Adjusting the Keyboard Touch (Touch Sensitivity)

You can adjust the volume level that changes depending on how fast or strong you hit the keys. The following four settings are available.

- A6The volume level does not change at all regardless of whether you play the keyboard soft or hard.
- A#6The volume level does not change much when you play the keyboard soft or hard.
- B6This is the standard piano touch response. (This is the default setting.)
- C7The volume level changes very widely from pianissimo to fortissimo to facilitate dynamic and dramatic expression. You have to hit the keys hard to produce a loud sound.

This setting is disabled with some voices, such as an organ sound.

Procedure

While holding down the **[PIANO/VOICE]** button, press one of the A6–C7 keys to select the desired touch sensitivity.

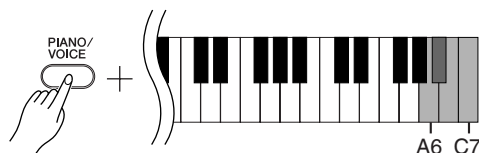

Recording your Performance

Your digital piano's recording function enables you to record your performance of one song.

The recorded performance is called the "user song."

Follow the steps below to record and play back your performance.

Audio recording and data recording

Cassette tape recordings use a different data format than this instrument. Cassette tapes record audio signals. On the other hand, this instrument records information about the notes and voices being played and about the timing and tempo of those notes. It does not record audio signals. When you play back a recorded performance on this instrument, its internal tone generator reproduces the sound according to the recorded information.

⚠ CAUTION

Be careful not to erase the recorded data:

After you record a performance on this instrument, the [PLAY] button indicator lights up. When this indicator remains on, recording another performance will erase the recorded data.

Procedure

1. Select a voice and other settings for the recording.

While holding down the [PIANO/VOICE] button, press one of the C1–A1 keys to select the desired voice(s). (See page 18.)

If you desire, you can select other settings, such as the reverb setting.

Use the [MASTER VOLUME] control to adjust the volume to a comfortable listening level. You can also use the [MASTER VOLUME] control to adjust the volume level during playback.

2. Engage Record mode.

Press the [REC] button.



Press the [REC] button again if you wish to cancel Record mode.

3. Start recording.

Recording starts as soon as you play the keyboard.

Alternatively, press the [PLAY] button to start recording.

4. Stop recording.

Press the [REC] button.

You cannot engage Record mode while a demo song is playing.

Recording capacity

"Recording capacity" is the maximum amount of performance data that you can record. This instrument's recording capacity is 65 KB (approximately 11,000 notes).

Changing the settings for the recorded user song

To change the settings for the recorded user song, engage Record mode, change the settings as you desire, then stop recording without playing the keyboard. For example, if you wish to change the voice of the user song, press the [REC] button to engage Record mode (see Step 2), then select a different voice (see Step 1). Without playing the keyboard, press the [REC] button to stop recording (see Step 4).

⚠ CAUTION

Do not turn off the power to this instrument while it is recording the data in its internal memory (that is, while the [REC] and [PLAY] button indicators are flashing). Otherwise, all recorded data, including the data being recorded, will be lost.

You can save the recorded user song to a computer. You can also load the user song data from a computer and play it back on this instrument. (See page 31.)

Playing Back Recorded Performance Data

Procedure

1. Start the playback.

Press the [PLAY] button.



2. Stop the playback.

When the user song finishes playing back, this instrument automatically returns to the previous mode.

To stop the playback, press the [PLAY] button.

You cannot adjust the tempo of the recorded user song. The user song always plays at the recorded tempo.

Connecting MIDI Instruments

Your digital piano features MIDI connectors. Using the MIDI functions enables you to access a variety of musical genres.

About MIDI

MIDI (Musical Instrument Digital Interface) is a global format standard for performance data transmission and reception between electronic musical instruments.

Connecting musical instruments that support MIDI via MIDI cables enables you to transfer performance and setting data between multiple musical instruments. Using MIDI, you can also achieve more advanced performances than using just a single musical instrument.

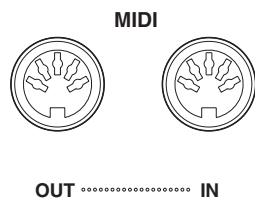

MIDI's Capability

MIDI functions enable you to transfer performance data between MIDI devices, load song data from a connected computer to your instrument, and transmit and save user song data to a computer.

● Transferring performance data to and from another MIDI device

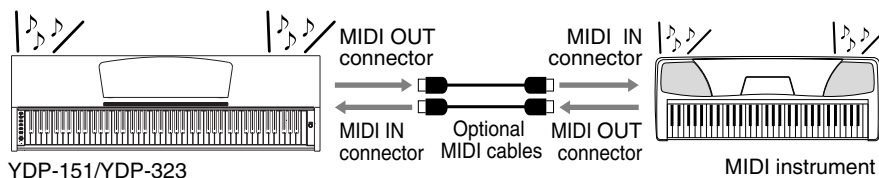

● Transferring MIDI data to and from a computer

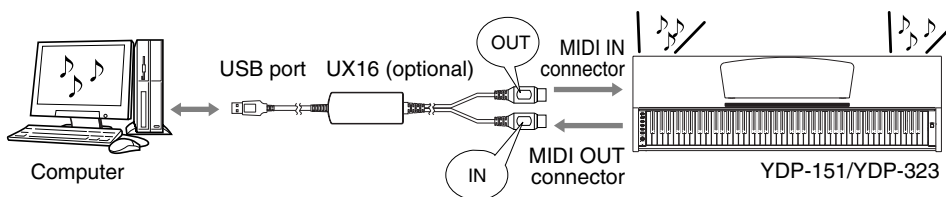

Since MIDI data that can be transmitted or received varies depending on the type of MIDI device, check the "MIDI Implementation Chart" to find out what MIDI data and commands your devices can transmit or receive. This instrument's MIDI Implementation Chart appears on page 44.

You need a dedicated MIDI cable (optional) to make a MIDI connection. You can purchase MIDI cables at musical instrument stores.

If you connect a very long MIDI cable, data transmission errors may result. Use a MIDI cable of 15 meters or less.

Before connecting a MIDI device to this instrument, first turn off the power to both this instrument and the MIDI device. After connecting them, turn on the power to the MIDI device first, then turn on the power to this instrument.

You cannot transmit the voice demo songs and the 50 piano preset songs from this instrument to another MIDI device.

For more information on the transmission and reception of song data, refer to "Transmitting Song Data between the Computer and the Digital Piano" on page 31.

Connecting the Digital Piano to a Computer

Connecting the digital piano to a computer using the MIDI connectors enables you to transfer MIDI data between the piano and the computer.

When this instrument is used as a tone module, performance data with voices that are not found on this instrument will not be played correctly.

Before you connect this instrument to a computer, first turn off the power to both this instrument and the computer. After you make the connections, turn on the power to the computer first, then turn on the power to this instrument.

An example of connecting this instrument to the USB port on a computer

Use an optional USB-MIDI interface (such as a Yamaha UX16) to connect this instrument's MIDI connectors to the computer's USB port.

You must install the USB-MIDI driver on the computer correctly so that you can control your MIDI instrument from the computer. The USB-MIDI driver is a software application that enables MIDI signals to be transmitted between the sequence software on the computer and the connected MIDI instrument. For more information, refer to the user's manual that came with the USB interface device.

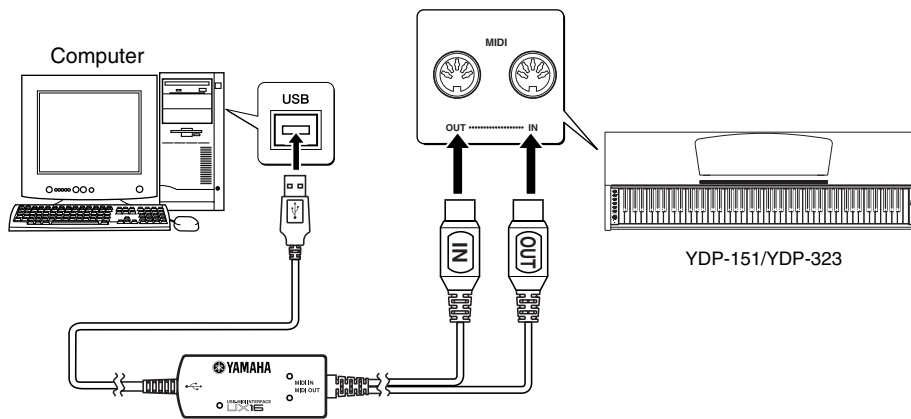

Connecting this instrument to the computer using a UX16

Turn off the power to this instrument. Connect the MIDI OUT cable from the USB-MIDI interface to this instrument's MIDI IN connector, and connect the MIDI IN cable from the USB-MIDI interface to this instrument's MIDI OUT connector.

The connection between this instrument and the computer has now been established.

Turn on the power to this instrument and try to transfer MIDI data to or from the computer.

For more information on connecting the UX16, refer to the user's manual that came with the UX16.

You must install a software application on the computer to be able to transfer MIDI data between this instrument and a computer.

MIDI Functions

You can make detailed adjustments to MIDI settings.

MIDI Transmit/Receive Channel Selection

In any MIDI control setup, the MIDI channels of the transmitting and receiving equipment must be matched for proper data transfer.

This parameter enables you to specify the channel on which the digital piano transmits or receives MIDI data.

Procedure

Setting the transmit channel

While holding down the [DEMO/SONG] and [PIANO/VOICE] buttons simultaneously, press one of the C1-E2 keys.

Setting the receive channel

While holding down the [DEMO/SONG] and [PIANO/VOICE] buttons simultaneously, press one of the C4-F5 keys.

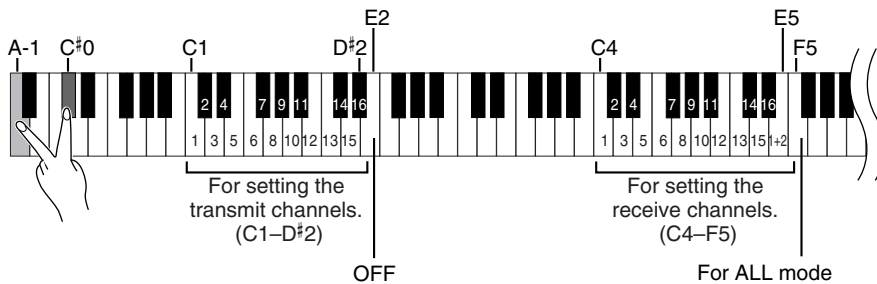

In Dual mode, Voice 1 data is transmitted on its specified channel and Voice 2 data is transmitted on the next greater channel number relative to the specified channel. In this mode, no data is transmitted if the transmit channel is set to "OFF."

ALL:

A "Multi-timbre" Receive mode is available. In this mode, this instrument receives different parts from the connected MIDI device on any or all 16 MIDI channels and plays multi-channel song data.

1+2:

A "1+2" Receive mode is available. It allows simultaneous reception on channels 1 and 2 only, enabling this instrument to play 1 and 2 channel song data received from a music computer or sequencer.

Program change and other like channel messages received will not affect this instrument's panel settings or the notes you play on the keyboard.

Data for the demo song and 50 piano preset songs cannot be transmitted via MIDI.

Local Control ON/OFF

"Local Control" refers to the fact that, normally, the keyboard of this digital piano controls its internal tone generator, allowing the internal voices to be played directly from the keyboard. This situation is "Local Control On," since the internal tone generator is controlled locally by its own keyboard.

Local control can be turned OFF, however, so that the keyboard of this digital piano does not play the internal voices, but the appropriate MIDI information is still transmitted via the MIDI OUT connector when notes are played on the keyboard. At the same time, the internal tone generator responds to MIDI information received via the MIDI IN connector.

Procedure

While holding down the [DEMO/SONG] and [PIANO/VOICE] buttons simultaneously, press the C6 key. Pressing the C6 key repeatedly toggles between Local Control On and Off.

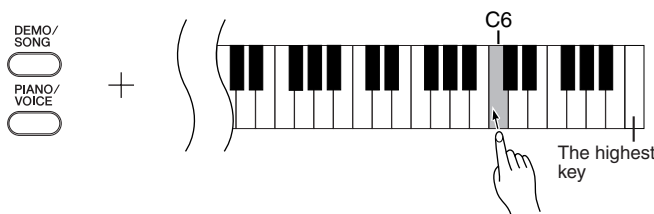

CAUTION

When Local control is turned OFF, the keyboard of this instrument does not play the internal voices.

Program Change ON/OFF

Normally this instrument will respond to MIDI program change numbers received from an external keyboard or other MIDI device, causing the correspondingly-numbered voice to be selected on the corresponding channel (the keyboard voice does not change). This instrument will normally also send a MIDI program change number whenever one of its voices is selected, causing the correspondingly-numbered voice or program to be selected on the external MIDI device if the device is set up to receive and respond to MIDI program change numbers.

This function makes it possible to cancel program change number reception and transmission so that voices can be selected on this instrument without affecting the external MIDI device.

For information on program change numbers for each of this instrument's voices, refer to page 40 in the MIDI Data Format section.

Procedure

While holding down the **[DEMO/SONG]** and **[PIANO/VOICE]** buttons simultaneously, press the **C#6** key. Pressing the **C#6** key repeatedly toggles between Program Change On and Off.

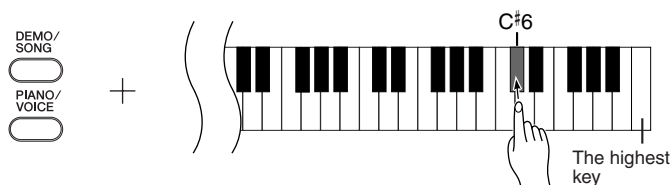

Control Change ON/OFF

MIDI Control Change data refers to MIDI information related to performance expression (such as damper pedal information).

You can transmit MIDI Control Change data from this instrument to control the operation of the connected MIDI device. (For example, if you operate this instrument's damper pedal, this instrument will transmit MIDI Control Change data.)

On the other hand, MIDI performance data of this instrument will respond to MIDI Control Change data received from the connected MIDI device. (At this time, the voice you are playing on the keyboard will not be affected by the Control Change data.)

The ability to transmit and receive MIDI Control Change data is sometimes very useful. Turn Control Change On if it is convenient for you to have this capability. Turn Control Change Off if you rather prefer not to have this capability.

For information on control changes that can be used with this instrument, refer to the MIDI Data Format on page 40.

Procedure

While holding down the **[DEMO/SONG]** and **[PIANO/VOICE]** buttons simultaneously, press the **D6** key. Pressing the **D6** key repeatedly toggles between Control Change On and Off.

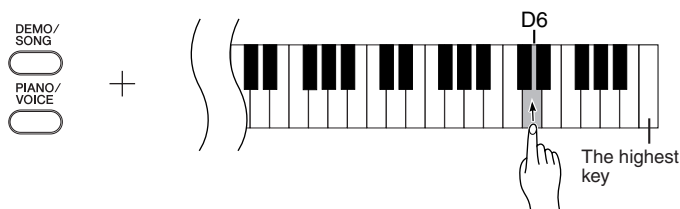

Transmitting Song Data between the Computer and the Digital Piano

In addition to the demo songs and the 50 piano preset songs stored in this instrument, you can play data for other song by loading it from a connected computer.

To be able to use this function, you must first download Musicsoft Downloader from Yamaha website at the following URL, and install it on your computer.

<http://music.yamaha.com/download/>

● System requirement for Musicsoft Downloader

- | | |
|---------------------------------|---|
| • OS | : Windows 98SE/Me/2000/XP Home Edition/XP Professional |
| • CPU | : Intel® Pentium® or Celeron® chip of 233MHz or higher (500MHz or higher recommended) |
| • Memory | : 64MB or higher (256MB or higher recommended) |
| • Available hard disk capacity: | 128MB or higher (512MB or higher recommended) |
| • Display | : 800 × 600 High Color (16-bit) |
| • Others | : Microsoft® Internet Explorer® version 5.5 or higher |

Loading Song Data from a Computer to the Digital Piano

You can load piano song data from a computer to this instrument. Also, after you record your performance on this instrument and save the recording to a computer, you can load the recording back to the instrument.

This instrument can read MIDI data in SMF Format 0. However, if such data includes any information for functions that are not supported by this instrument, the instrument will not play the data correctly.

For more information on loading song data from a computer to this instrument, please refer to “Transferring Data Between the Computer and Instrument (for unprotected data)” in the Help file that came with Musicsoft Downloader.

● Requirements for song data that can be loaded from a computer to this instrument

- | | |
|---------------------|--|
| • Number of songs | : Up to 10 songs plus one user song |
| • Maximum data size | : Total 352 KB |
| • Data format | : SMF Format 0 and YDP-151.BUP (user song) |

Transmitting Song Data from the Digital Piano to a Computer

Musicsoft Downloader enables you to transfer the user song in this instrument to a computer. For more information on transferring song data from this instrument to a computer, please refer to “Transferring Data Between the Computer and Instrument (for unprotected data)” in the Help file that came with Musicsoft Downloader.

● Data you can transfer from this instrument to a computer

- | | |
|---|---------------|
| • User song | : YDP-151.BUP |
| • Song data (once it has been loaded from the computer) | |

You can download free Musicsoft Downloader from the Yamaha website.

SMF (Standard MIDI File)

This file features a popular sequence format (for recording performance data). This file is sometimes called a “MIDI file.” The file extension is MID.

You can play the SMF format song using music software or a sequencer that supports SMF. This instrument also supports SMF.

⚠ CAUTION

Do not turn off the power to this instrument or unplug the instrument during data transmission. Otherwise, the data being transmitted will not be saved. Furthermore, flash memory operation may become unstable, causing the entire memory to be erased when you turn the power to the instrument on or off.

Before you use this instrument, close the Musicsoft Downloader window and quit the application.

Backing up Data and Initializing the Settings

Backing up data to flash memory

The following items will be stored in flash memory on this instrument. This data will be kept after you turn off the power to the instrument.

Backup data
Metronome volume
Metronome tempo
Touch sensitivity
Tuning
Recorded performance data (user song)
Song data once loaded from a computer

Initializing the settings

When you initialize the settings, all data, excluding the user song and songs loaded from a computer, will be initialized and reset to the factory default settings.

While holding down the C7 (the highest) key, turn on the power to the instrument.

- ⇒ The data (excluding the data for the recorded performance and songs loaded from a computer) will be initialized.

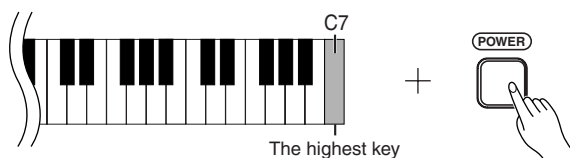

CAUTION

Do not turn off the power to this instrument while it is initializing the data in its internal memory (that is, while the [REC] and [PLAY] button indicators are flashing).

If this instrument somehow becomes disabled or malfunctions, turn off the power to the instrument, then perform the initialization procedure.

Troubleshooting

Problem	Possible Cause and Solution
This instrument does not turn on.	This instrument has not been plugged in properly. Securely insert the female plug into the socket on this instrument, and the male plug into a proper AC outlet (page 11).
A click or pop is heard when the power is turned on or off.	This is normal when electrical current is being applied to the instrument.
Noise from the speakers or headphones is audible.	The noise may be due to interference caused by the use of a mobile phone in close proximity to this instrument. Turn off the mobile phone, or move it further away from this instrument.
The overall volume is low, or no sound is heard.	<ul style="list-style-type: none">• The Master Volume is set too low. Set it to an appropriate level using the [MASTER VOLUME] control.• Make sure a pair of headphones is not connected to the headphones jack.• Make sure that Local Control (page 29) is ON.
The damper pedal has no effect, or the sound continuously sustains even when the damper pedal is not pressed.	The pedal cord may not be properly connected. Make sure to securely insert the pedal cord into the [PEDAL] jack (page 36).

Options

BC-100 Bench

A comfortable bench styled to match your Yamaha digital piano.

UX16

USB-MIDI interface

Keyboard Stand Assembly

⚠ CAUTION

- Be careful not to confuse parts, and be sure to install all parts in the correct direction. Please assemble in accordance with the sequence given below.
- Assembly should be carried out by at least two persons.
- Be sure to use the included screws only, and insert screws of the correct size in the correct hole locations. Do not use any other screws. Use of incorrect screws can cause damage or malfunction of the product.
- Be sure to tighten up all screws upon completing assembly of each unit.
- To disassemble, reverse the assembly sequence given below.

Have a Phillips-head (+) screwdriver ready

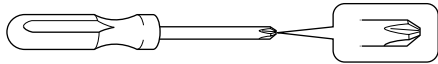

Remove all parts from the package and make sure you have all of the items.

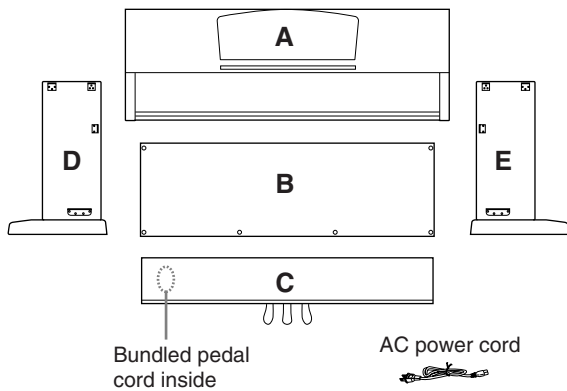

Assembly Parts

6 × 20 mm long screws × 4 ❶



4 × 20 mm tapping screws × 4 ❷

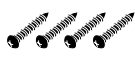

6 × 16 mm short screws × 4 ❸



Cord holders × 2



4 × 12 mm thin screws × 2 ❹



Headphone hanger set

4 × 10 mm thin screws × 2 ❺



Headphone hanger



1. Attach (finger-tighten) C to D and E.

- 1-1 Untie and straighten out the bundled pedal cord. Don't discard the vinyl tie. You will need it later in step 6.
- 1-2 Align D and E with each end of C.
- 1-3 Attach D and E to C by finger-tightening the long screws ❶ (6 × 20mm).

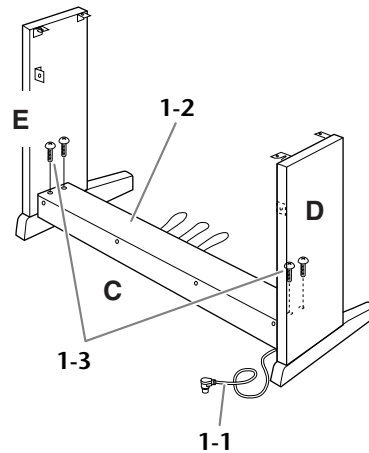

2. Attach B.

Depending on the model of digital piano you purchased, the surface color of one side of B may be different from the other side. In this case, position B so that the side of the surface color similar to D and E faces the player.

- 2-1 Place the lower side of B on each foot of D and E, then attach the upper side to D and E.
- 2-2 Attach the top of B to D and E by finger-tightening the thin screws ❸ (4 × 12mm).
- 2-3 While pushing the lower part of D and E from outside, secure the bottom ends of B using two tapping screws ❷ (4 × 20mm).
- 2-4 Insert the other two tapping screws ❷ (4 × 20mm) into the other two screw holes to secure B.

2-5 Securely tighten the screws on the top of B that were attached in Step 2-2.

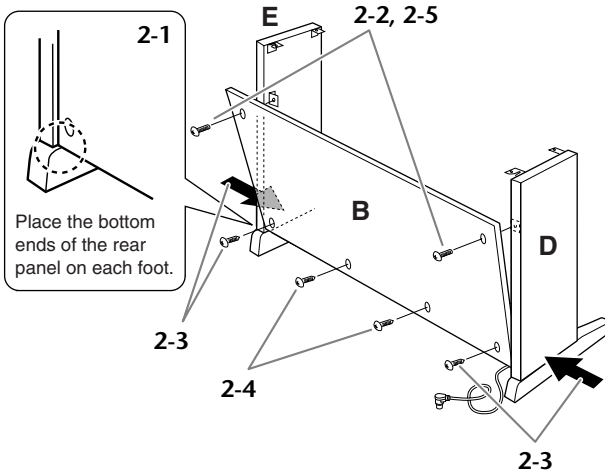

3. Securely tighten the screws on C that were attached in Step 1-3.

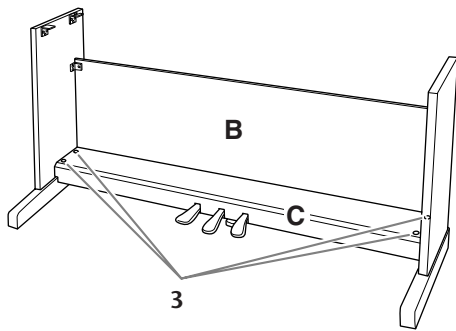

4. Mount A.

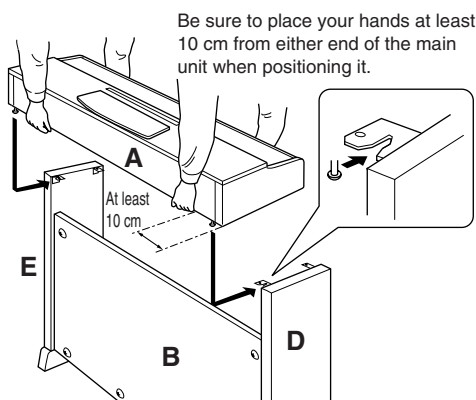

CAUTION

- Fingers can become pinched between the main unit and the rear or side panels, be extra careful so as not to drop the main unit.
- Do not hold the keyboard in any position other than the position shown in the illustration.

5. Secure A.

5-1 Adjust the position of A so that the left and right ends of A will project beyond D and E equally when seen from the front.

5-2 Secure A by tightening the short screws ② (6 × 16mm) from the front.

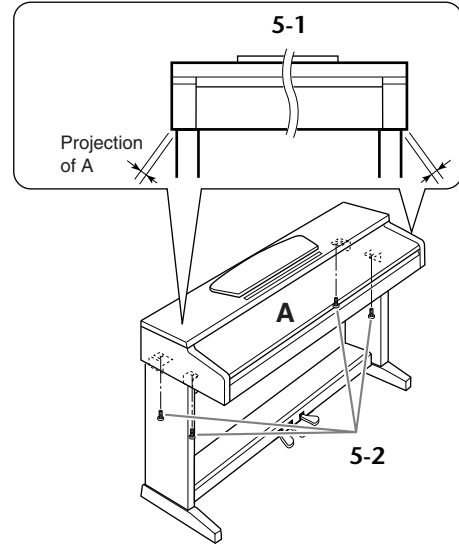

6. Connect the pedal cord.

6-1 Insert the pedal cord plug to the pedal connector from the rear.

6-2 Attach the cord holders to the rear panel as shown, then clip the cord into the holders.

6-3 Use a vinyl tie to take up any slack in the pedal cord.

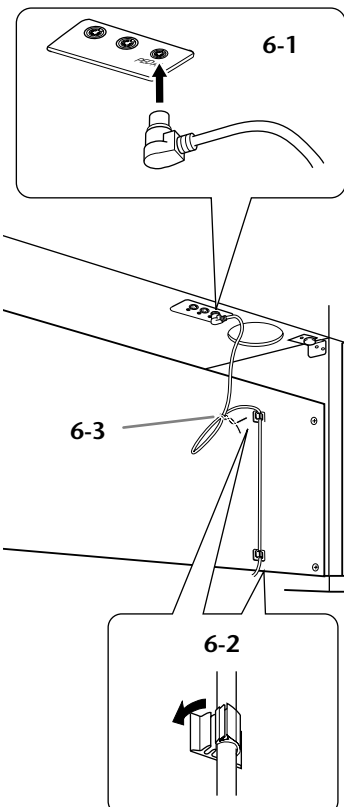

- 7.** Set the voltage selector and connect the power cord.

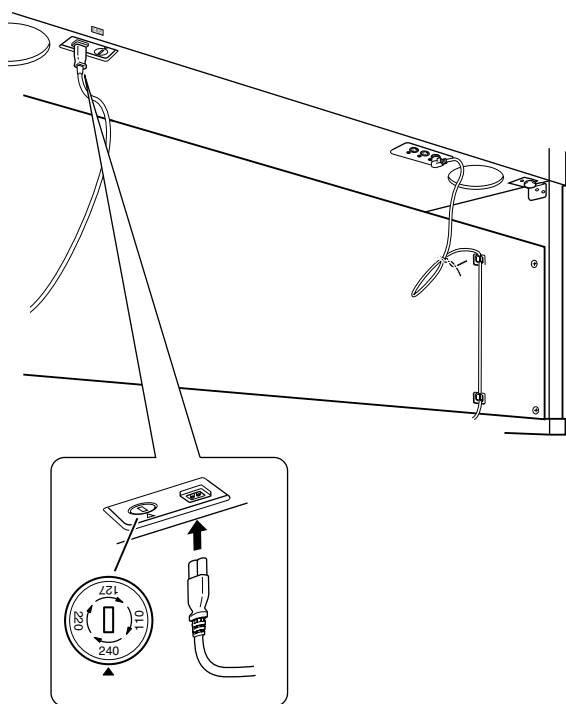

Voltage Selector

Before connecting the AC power cord, check the setting of the voltage selector which is provided in some areas. To set the selector for 110V, 127V, 220V or 240V main voltages, use a “minus” screwdriver to rotate the selector dial so that the correct voltage for your region appears next to the pointer on the panel. The voltage selector is set at 240V when the unit is initially shipped. After the proper voltage has been selected, connect the AC power cord to the AC INLET and an AC wall outlet. A plug adaptor may be also provided in some areas to match the pin configuration of the AC wall outlets in your area.

⚠ WARNING

An improper voltage setting can cause serious damage to this instrument or result in improper operation.

- 8.** Set the adjuster.

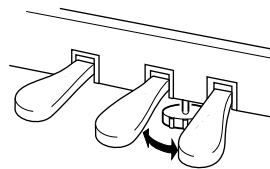

Rotate the adjuster until it comes in firm contact with the floor surface.

- 9.** Attach the headphone hanger.

Use the included two screws **5** (4x10mm) to attach the hanger as shown in the illustration below.

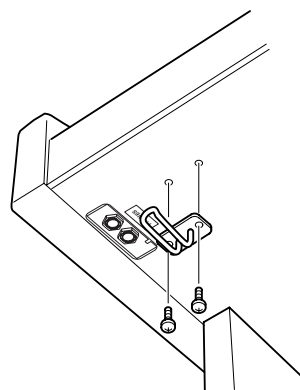

After completing the assembly, please check the following.

- **Are there any parts left over?**
→ Review the assembly procedure and correct any errors.
- **Is this instrument clear of doors and other movable fixtures?**
→ Move the instrument to an appropriate location.
- **Does this instrument make a rattling noise when you shake it?**
→ Tighten all screws.
- **Does the pedal box rattle or give way when you step on the pedals?**
→ Turn the adjuster so that it is set firmly against the floor.
- **Are the pedal and power cords inserted securely into the sockets?**
→ Check the connection.
- **If the main unit creaks or is otherwise unsteady when you play on the keyboard, refer to the assembly diagrams and retighten all screws.**

When moving the instrument after assembly, always hold the bottom of the main unit.

⚠ CAUTION

Do not hold the key cover or top portion. Improper handling can result in damage to the instrument or personal injury.

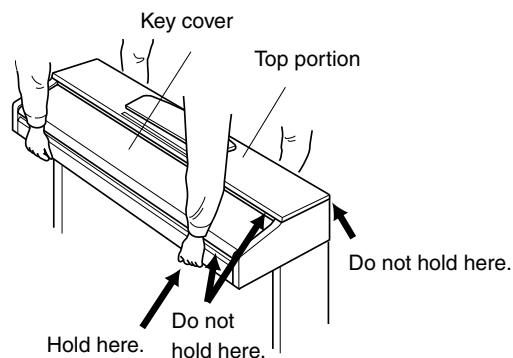

Index

Numerics

50 Piano Preset Songs 16

A

Accessories 8

Adjust

Keyboard Touch 24

Reverb Depth 20

Tempo (metronome) 23

Volume (metronome) 24

Assembly 34–36

C

Center Pedal 14, 19

Connecting a Computer 28

D

Damper Pedal 14, 19

DEMO/SONG 14, 15–17

Dual mode 21

I

Initializing the Settings 32

K

Key Cover 10

Keyboard Stand 34–36

L

Layering Two Voices (Dual mode) 21

Left Pedal 14, 19

M

MASTER VOLUME 12, 14

METRONOME 14, 23

MIDI 27

MIDI [IN] [OUT] 14, 27, 28

MIDI cables 27

MIDI connectors 27, 28

MIDI Data Format 40

MIDI Implementation Chart 44

Music Rest 10

Musicsoft Downloader 31

P

PEDAL 14, 19, 35

PHONES 12, 14

PIANO/VOICE 14, 18

PLAY 14, 26

Playing Back Recorded Performance Data 26

POWER 11, 14

Precautions 3–4

Preset songs → 50 Piano Preset Songs 16

R

REC 14, 25

Recording your Performance 25

Reverb 20

Right Pedal 14, 19

S

SELECT 14–16

Soft Pedal 14, 19

Song 16

Sostenute Pedal 14, 19

Specifications 45

Stand 34–36

Start/Stop playback

50 Piano Preset Songs 16

Demo Songs 15

User Song 26

T

Touch Sensitivity 24

Transmitting Song Data 31

Transporting 8

Transposition 22

Troubleshooting 33

U

User Song 25

MEMO

ENGLISH

Appendix / Anhang / Annexe / Apéndice

This section introduces reference material.

In diesem Abschnitt finden Sie Referenzmaterial.

Cette section présente le matériel de référence.

En esta sección se incluye material de referencia.

MIDI Data Format / MIDI-Datenformat / Format des données MIDI / Formato de datos MIDI	40
MIDI Implementation Chart / MIDI Implementierung stabelle / Feuille d'implantation MIDI / Gráfica de implementación MIDI	44
Specifications / Technische Daten / Caractéristiques techniques / Especificaciones	45

MIDI Data Format / MIDI-Datenformat / Format des données MIDI / Formato de datos MIDI

If you're already very familiar with MIDI, or are using a computer to control your music hardware with computer-generated MIDI messages, the data provided in this section can help you to control this instrument.

Falls Sie bereits mit MIDI vertraut sind oder einen Computer zur Erzeugung von MIDI-Steuermeldungen für die Instrumente verwenden, können Sie sich zur Steuerung des YDP-151/YDP-323 nach den im folgenden Abschnitt aufgeführten Spezifikationen richten.

1. NOTE ON/OFF

Data format: [9nH] -> [kk] -> [vv]

9nH = Note ON/OFF event (n = channel number)
kk = Note number (Transmit: 09H ~ 78H = A-2 ~ C8 /
Receive: 00H ~ 7FH = C-2 ~ G8)
vv = Velocity (Key ON = 01H ~ 7FH, Key OFF = 00H)

Data format: [8nH] -> [kk] -> [vv] (reception only)

8nH = Note OFF event (n = channel number)
kk = Note number: 00H ~ 7FH = C-2 ~ G8)
vv = Velocity

2. CONTROL CHANGE

Data format: [BnH] -> [cc] -> [vv]

BnH = Control change (n = channel number)
cc = Control number
vv = Data Range

(1) Bank Select

ccH	Parameter	Data Range (vvH)
00H	Bank Select MSB	00H:Normal
20H	Bank Select LSB	00H...7FH

Bank selection processing does not occur until receipt of next Program Change message.

(2) Main Volume

ccH	Parameter	Data Range (vvH)
07H	Volume MSB	00H...7FH

(3) Expression (reception only)

ccH	Parameter	Data Range (vvH)
0BH	Expression MSB	00H...7FH

(4) Damper

ccH	Parameter	Data Range (vvH)
40H	Damper MSB	00H...7FH

(5) Sostenuto

ccH	Parameter	Data Range (vvH)
42H	Sostenuto	00H-3FH:off, 40H-7FH:on

(6) Soft Pedal

ccH	Parameter	Data Range (vvH)
43H	Soft Pedal	00H-3FH:off, 40H-7FH:on

(7) Effect1 Depth (Reverb Send Level)

ccH	Parameter	Data Range (vvH)
5BH	Effect1 Depth	00H...7FH

Adjusts the reverb send level.

(8) Effect4 Depth (Variation Effect Send Level)

ccH	Parameter	Data Range (vvH)
5EH	Effect4 Depth	00H...7FH

(9) RPN

65H	RPN	MSB
64H	RPN	LSB
06H	Data Entry	MSB
26H	Data Entry	LSB
60H	Data	Increment
61H	Data	Decrement

* Parameters that are controllable with RPN

- Coarse Tune
- Fine Tune
- Pitch Bend Range

Si vous êtes très familier avec l'interface MIDI ou si vous utilisez un ordinateur pour commander votre matériel de musique au moyen de messages MIDI générés par ordinateur, les données suivantes vous seront utiles et vous aideront à commander le YDP-151/YDP-323.

Si usted está ya familiarizado con MIDI, o si emplea una computadora para controlar sus aparatos musicales con mensajes MIDI generados por computadora, los datos proporcionados en esta sección le ayudarán a controlar la YDP-151/YDP-323.

3. MODE MESSAGES

Data format: [BnH] -> [cc] -> [vv]

BnH = Control event (n = channel number)
cc = Control number
vv = Data Range

(1) All Sound Off

ccH	Parameter	Data Range (vvH)
78H	All Sound Off	00H

(2) Reset All Controllers

ccH	Parameter	Data Range (vvH)
79H	Reset All Controllers	00H

Resets controllers as follows.

Controller	Value
Expression	127 (max)
Damper Pedal	0 (off)
Sostenuto	0 (off)
Soft Pedal	0 (off)

(3) Local Control (reception only)

ccH	Parameter	Data Range (vvH)
7AH	Local Control	00H (off), 7FH (on)

(4) All Notes Off

ccH	Parameter	Data Range (vvH)
7BH	All Notes Off	00H

Switches OFF all the notes that are currently ON on the specified channel. Any notes being held by the damper or sostenuto pedal will continue to sound until the pedal is released.

(5) Omni Off (reception only)

ccH	Parameter	Data Range (vvH)
7CH	Omni Off	00H

Same processing as for All Notes Off.

(6) Omni On (reception only)

ccH	Parameter	Data Range (vvH)
7DH	Omni On	00H

Same processing as for All Notes Off.

(7) Mono (reception only)

ccH	Parameter	Data Range (vvH)
7EH	Mono	00H

Same processing as for All Sound Off.

(8) Poly (reception only)

ccH	Parameter	Data Range (vvH)
7FH	Poly	00H

Same processing as for All Sound Off.

- When Control Change is turned OFF, Control Change messages will not be transmitted or received.
- Local on/off, OMNI on/off are not transmitted. (The appropriate note off number is supplied with "All Note Off" transmission).
- When a voice bank MSB/LSB is received, the number is stored in the internal buffer regardless of the received order, then the stored value is used to select the appropriate voice when a program change message is received.
- Poly mode is always active. This mode will not change when the instrument receives MONO/POLY mode message.

4. PROGRAM CHANGE

Data format: [CnH] -> [ppH]

CnH = Program event (n = channel number)

ppH = Program change number

P.C.#=Program Change number

YDP-151/YDP-323	MSB	LSB	P.C.#
Grand Piano 1	0	122	1
Grand Piano 2	0	112	1
E.Piano 1	0	122	6
E.Piano 2	0	122	5
Harpsichord 1	0	122	7
Harpsichord 2	0	123	7
Vibraphone	0	122	12
Church Organ 1	0	123	20
Church Organ 2	0	122	20
Strings	0	122	49

- When program change reception is turned OFF, no program change data is transmitted or received.
- When you specify a program change as a number in the range of 0-127, specify a number that is one less than the program change number listed above. For example, to specify program change number 1, you would specify program change 0.

5. Pitch Bend Change

[EnH] -> [ccH] -> [ddH]

ccH = LSB

ddH = MSB

6. SYSTEM REALTIME MESSAGES

[rrH]

F8H: Timing clock

FAH: Start

FCH: Stop

FEH: Active sensing

Data	Transmission	Reception
F8H	Transmitted every 96 clocks	Received as 96-clock tempo timing when MIDI clock is set to External.
FAH	Song start	Song start Not received when the MIDI clock is set to Internal.
FCH	Song stop	Song stop Not received when the MIDI clock is set to Internal.
FEH	Transmitted every 200 milliseconds	If a signal is not received via MIDI for more than 400 milliseconds, the same processing will take place for All Sound Off, All Notes Off and Reset All Controllers as when those signals are received.

- If an error occurs during MIDI reception, the Damper, Sostenu, and Soft effects for all channels are turned off and an All Note Off occurs.

7. SYSTEM EXCLUSIVE MESSAGES (Universal System Exclusive)

(1) Universal Realtime Message

Data format: [F0H] -> [7FH] -> [XnH] -> [04H] -> [01H] -> [IH] -> [mmH] -> [F7H]

MIDI Master Volume

- Simultaneously changes the volume of all channels.
- When a MIDI master volume message is received, the volume only has affect on the MIDI receive channel, not the panel master volume.

F0H = Exclusive status

7FH = Universal Realtime

7FH = ID of target device

04H = Sub-ID #1=Device Control Message

01H = Sub-ID #2=Master Volume

//H = Volume LSB

mmH = Volume MSB

F7H = End of Exclusive

or

F0H = Exclusive status

7FH = Universal Realtime

XnH = When n is received n=0~F, whichever is received.

X = don't care

04H = Sub-ID #1=Device Control Message

01H = Sub-ID #2=Master Volume

//H = Volume LSB

mmH = Volume MSB

F7H = End of Exclusive

(2) Universal Non-Realtime Message (GM On)

General MIDI Mode On

Data format: [F0H] -> [7EH] -> [XnH] -> [09H] -> [01H] -> [F7H]

F0H = Exclusive status

7EH = Universal Non-Realtime

7FH = ID of target device

09H = Sub-ID #1=General MIDI Message

01H = Sub-ID #2=General MIDI On

F7H = End of Exclusive

or

F0H = Exclusive status

7EH = Universal Non-Realtime

XnH = When received, n=0~F.

X = don't care

09H = Sub-ID #1=General MIDI Message

01H = Sub-ID #2=General MIDI On

F7H = End of Exclusive

When the General MIDI mode ON message is received, the MIDI system will be reset to its default settings.

This message requires approximately 50ms to execute, so sufficient time should be allowed before the next message is sent.

8. SYSTEM EXCLUSIVE MESSAGES (XG Standard)

(1) XG Native Parameter Change

Data format: [F0H] -> [43H] -> [1nH] -> [4CH] -> [hhH] -> [mmH] -> [lH] -> [ddH] -> [F7H]

F0H = Exclusive status
 43H = YAMAHA ID
 1nH = When received, n=0~F.
 When transmitted, n=0.
 4CH = Model ID of XG
 hhH = Address High
 mmH = Address Mid
 lH = Address Low
 ddH = Data
 |
 F7H = End of Exclusive

Data size must match parameter size (2 or 4 bytes).

When the XG System On message is received, the MIDI system will be reset to its default settings.

The message requires approximately 50ms to execute, so sufficient time should be allowed before the next message is sent.

(2) XG Native Bulk Data (reception only)

Data format: [F0H] -> [43H] -> [0nH] -> [4CH] -> [aaH] -> [bbH] -> [hhH] -> [mmH] -> [lH] -> [ddH] -> ... -> [ccH] -> [F7H]

F0H = Exclusive status
 43H = YAMAHA ID
 0nH = When received, n=0~F.
 When transmitted, n=0.
 4CH = Model ID of XG
 aaH = ByteCount
 bbH = ByteCount
 hhH = Address High
 mmH = Address Mid
 lH = Address Low
 ddH = Data
 | |
 | |
 ccH = Check sum
 F7H = End of Exclusive

- Receipt of the XG SYSTEM ON message causes reinitialization of relevant parameters and Control Change values. Allow sufficient time for processing to execute (about 50 msec) before sending this instrument another message.
- XG Native Parameter Change message may contain two or four bytes of parameter data (depending on the parameter size).
- For information about the Address and Byte Count values, refer to Table 1 below. Note that the table's Total Size value gives the size of a bulk block. Only the top address of the block (00H, 00H, 00H) is valid as a bulk data address.

9. SYSTEM EXCLUSIVE MESSAGES (Digital Piano MIDI Format)

Data format: [F0H] -> [43H] -> [73H] -> [xxH] -> [nnH] -> [F7H]

F0H = Exclusive status
 43H = Yamaha ID
 73H = Digital Piano ID
 01H = Product ID (digital piano common)
 xxH = Substatus
 nn Control
 02H Internal MIDI clock
 03H External MIDI clock
 06H Bulk Data (the bulk data follows 06H)
 F7H = End of Exclusive

10. SYSTEM EXCLUSIVE MESSAGES (Special Control)

Data format: [F0H] -> [43H] -> [73H] -> [66H] -> [11H] -> [0nH] -> [ccH] -> [vvH] -> [F7H]

F0H = Exclusive status
 43H = Yamaha ID
 73H = Digital Piano ID
 7FH = Extended Product ID
 4BH = Product ID
 11H = Special control
 0nH = Control MIDI change (n=channel number)
 cc = Control number
 vv = Value
 F7H = End of Exclusive

Control	Channel	ccH	vvH
Metronome	Always 00H	1BH	00H : off
			01H : -
			02H : 2/4
			03H : 3/4
			04H : 4/4
			05H : 5/4
			06H : 6/4
Channel Detune ch:	00H-0FH	43H	(Sets the Detune value for each channel)
			00H-7FH
Voice Reserve ch:	00H-0FH	45H	00H : Reserve off 7FH : on*

* When Volume, Expression is received for Reserve On, they will be effective from the next Key On. Reserve Off is normal.

11. SYSTEM EXCLUSIVE MESSAGES (Others)

Data format: [F0H] -> [43H] -> [1nH] -> [27H] -> [30H] -> [00H] -> [00H] -> [mmH] -> [lH] -> [ccH] -> [F7H]

Master Tuning (XG and last message priority) simultaneously changes the pitch of all channels.

F0H = Exclusive Status
 43H = Yamaha ID
 1nH = When received, n=0~F.
 When transmitted, n=0.
 27H = Model ID of TG100
 30H = Sub ID
 00H =
 00H =
 mmH = Master Tune MSB
 lH = Master Tune LSB
 ccH = don't care (under 7FH)
 F7H = End of Exclusive

<Table 1>

MIDI Parameter Change table (SYSTEM)

Address (H)	Size (H)	Data (H)	Parameter	Description	Default value (H)
00 00 00	4	020C - 05F4(*1)	MASTER TUNE	-50 - +50[cent]	00 04 00 00
01				1st bit 3 - 0 → bit 15 - 12	400
02				2nd bit 3 - 0 → bit 11 - 8	
03				3rd bit 3 - 0 → bit 7 - 4	
04	1	00 - 7F	MASTER VOLUME	0 - 127	7F
7E		00	XG SYSTEM ON	00=XG sytem ON	
7F		00	RESET ALL PARAMETERS	00=ON (receive only)	
TOTAL SIZE 07					

*1: Values lower than 020CH select -50 cents. Values higher than 05F4H select +50 cents.

<Table 2>

MIDI Parameter Change table (EFFECT 1)

Refer to the "Effect MIDI Map" for a complete list of Reverb, Chorus and Variation type numbers.

Address (H)	Size (H)	Data (H)	Parameter	Description	Default value (H)
02 01 00	2	00-7F	REVERB TYPE MSB	Refer to Effect MIDI Map	01(=HALL1)
		00-7F	REVERB TYPE LSB	00 : basic type	00
02 01 40	2	00-7F	VARIATION TYPE MSB	Refer to Effect MIDI Map	00(=Effect off)
		00-7F	VARIATION TYPE LSB	00 : basic type	00

• "VARIATION" refers to the EFFECT on the panel.

<Table 3>

MIDI Parameter Change table (MULTI PART)

Address (H)	Size (H)	Data (H)	Parameter	Description	Default value (H)
08 nn 11	1	00 - 7F	DRY LEVEL	0 - 127	7F

nn = Part Number

• **Effect MIDI Map**

REVERB

	MSB	LSB
ROOM	02H	10H
HALL 1	01H	10H
HALL 2	01H	11H
STAGE	03H	10H
OFF	00H	00H

EFFECT

	MSB	LSB
CHORUS	42H	10H
PHASER	48H	10H
TREMOLO	46H	10H
ROTARY SP	47H	10H
OFF	00H	00H

Function...	Transmitted	Recognized	Remarks
Basic Channel Default Changed	1-16 x	1-16 1-16	
Mode Default Messages Altered	3 x *****	3 x x	
Note Number : True voice	0-127 *****	0-127 0-127	
Velocity Note ON Note OFF	o 9nH, v=1-127 x	o 9nH, v=1-127 x	
After Touch Key's Ch's	x *1 x	x x	
Pitch Bend	x *1	o 0-24 semi	
Control Change 0, 32 1 7 10 11 6, 38 64, 66, 67 84 91, 94 96-97 100-101	o x *1 o x *1 x *1 x *1 o o x *1 o x *1 x *1	o o o o o o o o o o	Bank Select Modulation Main Volume Panpot Expression Data Entry Portament Control Effect Depth RPN Inc, Dec RPN LSB, MSB
Prog Change : True #	o 0 - 127 *****	o 0 - 127	
System Exclusive	o	o	
Common : Song Pos. : Song Sel. : Tune	x x x	x x x	
System : Clock Real Time : Commands	o o	o o	
Aux Messages : All Sound Off : Reset All Cntrls : Local ON/OFF : All Notes OFF : Active Sense : Reset	o o x o o x	o (120,126,127) o (121) o (122) o (123-125) o x	
Notes:	*1 These Control Change messages are not transmitted via panel operation, but may be transmitted during song playback.		

Mode 1 : OMNI ON, POLY
Mode 3 : OMNI OFF, POLY

Mode 2 : OMNI ON, MONO
Mode 4 : OMNI OFF, MONO

o : Yes
x : No

Specifications / Technische Daten / Caractéristiques techniques / Especificaciones

Item	YDP-151/YDP-323
Keyboard	88 keys (A-1 - C7)
Sound Source	AWM Stereo Sampling
Polyphony	64 Notes Max.
Voice Selection	10
Effect	Reverb
Volume	Master Volume
Controls	Dual, Metronome, Transpose
Pedal	Damper, Sostenuto, Soft
Demo Songs	10 Demo Songs, 50 Piano Preset Songs
Recording Function	One song 65 KB (approx. 11,000 notes)
Loading song data from a computer	Up to 10 songs; Total maximum size 352 KB
Jacks/Connectors	MIDI (IN/OUT), PHONES × 2
Main Amplifiers	20W × 2
Speakers	Oval (12cm × 6cm) × 2
Dimensions (W × D × H) (with music rest)	YDP-151: 1357mm × 420mm × 819mm [53-3/8" × 16-1/2" × 32-1/4"] (1357mm × 420mm × 973mm) [53-3/8" × 16-1/2" × 38-1/3"]
	YDP-323: 1357mm × 420mm × 814mm [53-3/8" × 16-1/2" × 32-1/16"] (1357mm × 420mm × 987mm) [53-3/8" × 16-1/2" × 38-7/8"]
Weight	41kg (90lbs., 6oz)
Accessories	Owner's Manual, "50 greats for the Piano" (Music Book), Bench (included or optional depending on locale), Quick Operation Guide, Headphone hanger set, Assembly parts

- * Specifications and descriptions in this owner's manual are for information purposes only. Yamaha Corp. reserves the right to change or modify products or specifications at any time without prior notice. Since specifications, equipment or options may not be the same in every locale, please check with your Yamaha dealer.
- * Die technischen Daten und Beschreibungen in dieser Bedienungsanleitung dienen nur der Information. Yamaha Corp. behält sich das Recht vor, Produkte oder deren technische Daten jederzeit ohne vorherige Ankündigung zu verändern oder zu modifizieren. Da die technischen Daten, das Gerät selbst oder Sonderzubehör nicht in jedem Land gleich sind, setzen Sie sich im Zweifel bitte mit Ihrem Yamaha-Händler in Verbindung.
- * Les caractéristiques techniques et les descriptions du mode d'emploi ne sont données que pour information. Yamaha Corp. se réserve le droit de changer ou modifier les produits et leurs caractéristiques techniques à tout moment sans aucun avis. Du fait que les caractéristiques techniques, les équipements et les options peuvent différer d'un pays à l'autre, adressez-vous au distributeur Yamaha le plus proche.
- * Las especificaciones y descripciones de este manual del propietario tienen sólo el propósito de servir como información. Yamaha Corp. se reserva el derecho a efectuar cambios o modificaciones en los productos o especificaciones en cualquier momento sin previo aviso. Puesto que las especificaciones, equipos u opciones pueden no ser las mismas en todos los mercados, solicite información a su distribuidor Yamaha.

MEMO

IMPORTANT SAFETY INSTRUCTIONS

INFORMATION RELATING TO PERSONAL INJURY, ELECTRICAL SHOCK, AND FIRE HAZARD POSSIBILITIES HAS BEEN INCLUDED IN THIS LIST.

WARNING- When using any electrical or electronic product, basic precautions should always be followed. These precautions include, but are not limited to, the following:

- 1.** Read all Safety Instructions, Installation Instructions, Special Message Section items, and any Assembly Instructions found in this manual **BEFORE** making any connections, including connection to the main supply.
- 2.** Main Power Supply Verification: Yamaha products are manufactured specifically for the supply voltage in the area where they are to be sold. If you should move, or if any doubt exists about the supply voltage in your area, please contact your dealer for supply voltage verification and (if applicable) instructions. The required supply voltage is printed on the name plate. For name plate location, please refer to the graphic found in the Special Message Section of this manual.
- 3.** This product may be equipped with a polarized plug (one blade wider than the other). If you are unable to insert the plug into the outlet, turn the plug over and try again. If the problem persists, contact an electrician to have the obsolete outlet replaced. Do **NOT** defeat the safety purpose of the plug.
- 4.** Some electronic products utilize external power supplies or adapters. Do **NOT** connect this type of product to any power supply or adapter other than one described in the owners manual, on the name plate, or specifically recommended by Yamaha.
- 5.** **WARNING:** Do not place this product or any other objects on the power cord or place it in a position where anyone could walk on, trip over, or roll anything over power or connecting cords of any kind. The use of an extension cord is not recommended! If you must use an extension cord, the minimum wire size for a 25' cord (or less) is 18 AWG. **NOTE:** The smaller the AWG number, the larger the current handling capacity. For longer extension cords, consult a local electrician.
- 6.** Ventilation: Electronic products, unless specifically designed for enclosed installations, should be placed in locations that do not interfere with proper ventilation. If instructions for enclosed installations are not provided, it must be assumed that unobstructed ventilation is required.
- 7.** Temperature considerations: Electronic products should be installed in locations that do not significantly contribute to their operating temperature. Placement of this product close to heat sources such as; radiators, heat registers and other devices that produce heat should be avoided.
- 8.** This product was **NOT** designed for use in wet/damp locations and should not be used near water or exposed to rain. Examples of wet/damp locations are; near a swimming pool, spa, tub, sink, or wet basement.
- 9.** This product should be used only with the components supplied or; a cart, rack, or stand that is recommended by the manufacturer. If a cart, rack, or stand is used, please observe all safety markings and instructions that accompany the accessory product.
- 10.** The power supply cord (plug) should be disconnected from the outlet when electronic products are to be left unused for extended periods of time. Cords should also be disconnected when there is a high probability of lightning and/or electrical storm activity.
- 11.** Care should be taken that objects do not fall and liquids are not spilled into the enclosure through any openings that may exist.
- 12.** Electrical/electronic products should be serviced by a qualified service person when:
 - a. The power supply cord has been damaged; or
 - b. Objects have fallen, been inserted, or liquids have been spilled into the enclosure through openings; or
 - c. The product has been exposed to rain; or
 - d. The product does not operate, exhibits a marked change in performance; or
 - e. The product has been dropped, or the enclosure of the product has been damaged.
- 13.** Do not attempt to service this product beyond that described in the user-maintenance instructions. All other servicing should be referred to qualified service personnel.
- 14.** This product, either alone or in combination with an amplifier and headphones or speaker/s, may be capable of producing sound levels that could cause permanent hearing loss. **DO NOT** operate for a long period of time at a high volume level or at a level that is uncomfortable. If you experience any hearing loss or ringing in the ears, you should consult an audiologist. **IMPORTANT:** The louder the sound, the shorter the time period before damage occurs.
- 15.** Some Yamaha products may have benches and/or accessory mounting fixtures that are either supplied as a part of the product or as optional accessories. Some of these items are designed to be dealer assembled or installed. Please make sure that benches are stable and any optional fixtures (where applicable) are well secured **BEFORE** using. Benches supplied by Yamaha are designed for seating only. No other uses are recommended.

PLEASE KEEP THIS MANUAL

FCC INFORMATION (U.S.A.)

1. **IMPORTANT NOTICE: DO NOT MODIFY THIS UNIT!**

This product, when installed as indicated in the instructions contained in this manual, meets FCC requirements. Modifications not expressly approved by Yamaha may void your authority, granted by the FCC, to use the product.

2. **IMPORTANT:** When connecting this product to accessories and/or another product use only high quality shielded cables. Cable/s supplied with this product **MUST** be used. Follow all installation instructions. Failure to follow instructions could void your FCC authorization to use this product in the USA.

3. **NOTE:** This product has been tested and found to comply with the requirements listed in FCC Regulations, Part 15 for Class "B" digital devices. Compliance with these requirements provides a reasonable level of assurance that your use of this product in a residential environment will not result in harmful interference with other electronic devices. This equipment generates/uses radio frequencies and, if not installed and used according to the instructions found in the users manual, may cause interference harmful to the operation of

other electronic devices. Compliance with FCC regulations does not guarantee that interference will not occur in all installations. If this product is found to be the source of interference, which can be determined by turning the unit "OFF" and "ON", please try to eliminate the problem by using one of the following measures:

Relocate either this product or the device that is being affected by the interference.

Utilize power outlets that are on different branch (circuit breaker or fuse) circuits or install AC line filter/s.

In the case of radio or TV interference, relocate/reorient the antenna. If the antenna lead-in is 300 ohm ribbon lead, change the lead-in to co-axial type cable.

If these corrective measures do not produce satisfactory results, please contact the local retailer authorized to distribute this type of product. If you can not locate the appropriate retailer, please contact Yamaha Corporation of America, Electronic Service Division, 6600 Orangethorpe Ave, Buena Park, CA90620

The above statements apply **ONLY** to those products distributed by Yamaha Corporation of America or its subsidiaries.

* This applies only to products distributed by YAMAHA CORPORATION OF AMERICA.

(class B)

IMPORTANT NOTICE FOR THE UNITED KINGDOM

Connecting the Plug and Cord

IMPORTANT. The wires in this mains lead are coloured in accordance with the following code:

BLUE : NEUTRAL

BROWN : LIVE

As the colours of the wires in the mains lead of this apparatus may not correspond with the coloured markings identifying the terminals in your plug proceed as follows:

The wire which is coloured BLUE must be connected to the terminal which is marked with the letter N or coloured BLACK.

The wire which is coloured BROWN must be connected to the terminal which is marked with the letter L or coloured RED.

Making sure that neither core is connected to the earth terminal of the three pin plug.

(2 wires)

- This applies only to products distributed by Yamaha-Kemble Music (U.K.) Ltd.

CAUTION: TO PREVENT ELECTRIC SHOCK, MATCH WIDE BLADE OF PLUG TO WIDE SLOT, FULLY INSERT.

ATTENTION: POUR ÉVITER LES CHOCS ÉLECTRIQUES, INTRODUIRE LA LAME LA PLUS LARGE DE LA FICHE DANS LA BORNE CORRESPONDANTE DE LA PRISE ET POUSSER JUSQU' AU FOND.

(polarity)

- This applies only to products distributed by Yamaha Canada Music Ltd.
- Ceci ne s'applique qu'aux produits distribués par Yamaha Canada Musique Ltée.

For details of products, please contact your nearest Yamaha representative or the authorized distributor listed below.

Pour plus de détails sur les produits, veuillez-vous adresser à Yamaha ou au distributeur le plus proche de vous figurant dans la liste suivante.

Die Einzelheiten zu Produkten sind bei Ihrer unten aufgeführten Niederlassung und bei Yamaha Vertragshändlern in den jeweiligen Bestimmungsländern erhältlich.

Para detalles sobre productos, contacte su tienda Yamaha más cercana o el distribuidor autorizado que se lista debajo.

NORTH AMERICA

CANADA

Yamaha Canada Music Ltd.
135 Milner Avenue, Scarborough, Ontario,
M1S 3R1, Canada
Tel: 416-298-1311

U.S.A.

Yamaha Corporation of America
6600 Orangethorpe Ave., Buena Park, Calif. 90620,
U.S.A.
Tel: 714-522-9011

CENTRAL & SOUTH AMERICA

MEXICO

Yamaha de México S.A. de C.V.
Calz. Javier Rojo Gómez #1149,
Col. Guadalupe del Moral
C.P. 09300, México, D.F., México
Tel: 55-5804-0600

BRAZIL

Yamaha Musical do Brasil Ltda.
Av. Reboucas 2636-Pinheiros CEP: 05402-400
Sao Paulo-SP. Brasil
Tel: 011-3085-1377

ARGENTINA

Yamaha Music Latin America, S.A.
Sucursal de Argentina
Viamonte 1145 Piso2-B 1053,
Buenos Aires, Argentina
Tel: 1-4371-7021

PANAMA AND OTHER LATIN AMERICAN COUNTRIES/ CARIBBEAN COUNTRIES

Yamaha Music Latin America, S.A.
Torre Banco General, Piso 7, Urbanización Marbella,
Calle 47 y Aquilino de la Guardia,
Ciudad de Panamá, Panamá
Tel: +507-269-5311

EUROPE

THE UNITED KINGDOM

Yamaha-Kemble Music (U.K.) Ltd.
Sherbourne Drive, Tilbrook, Milton Keynes,
MK7 8BL, England
Tel: 01908-366700

IRELAND

Danfay Ltd.
61D, Sallynoggin Road, Dun Laoghaire, Co. Dublin
Tel: 01-2859177

GERMANY

Yamaha Music Central Europe GmbH
Siemensstraße 22-34, 25462 Rellingen, Germany
Tel: 04101-3030

SWITZERLAND/LIECHTENSTEIN

Yamaha Music Central Europe GmbH,
Branch Switzerland
Seefeldstrasse 94, 8008 Zürich, Switzerland
Tel: 01-383 3990

AUSTRIA

Yamaha Music Central Europe GmbH,
Branch Austria
Schleiergasse 20, A-1100 Wien, Austria
Tel: 01-60203900

POLAND

Yamaha Music Central Europe GmbH
Sp.z o.o. Oddział w Polsce
ul. 17 Stycznia 56, PL-02-146 Warszawa, Poland
Tel: 022-868-07-57

THE NETHERLANDS

Yamaha Music Central Europe,
Branch Nederland
Clarissenhof 5-b, 4133 AB Vianen, The Netherlands
Tel: 0347-358 040

BELGIUM/LUXEMBOURG

Yamaha Music Central Europe GmbH,
Branch Belgium
Rue de Geneve (Genevstraat) 10, 1140 - Brussels,
Belgium
Tel: 02-726 6032

FRANCE

Yamaha Musique France
BP 70-77312 Marne-la-Vallée Cedex 2, France
Tel: 01-64-61-4000

ITALY

Yamaha Musica Italia S.P.A.
Viale Italia 88, 20020 Lainate (Milano), Italy
Tel: 02-935-771

SPAIN/PORTUGAL

Yamaha-Hazen Música, S.A.
Ctra. de la Coruna km. 17, 200, 28230
Las Rozas (Madrid), Spain
Tel: 91-639-8888

GREECE

Philippos Nakas S.A. The Music House
147 Skiathou Street, 112-55 Athens, Greece
Tel: 01-228 2160

SWEDEN

Yamaha Scandinavia AB
J. A. Wettergrens Gata 1
Box 30053
S-400 43 Göteborg, Sweden
Tel: 031 89 34 00

DENMARK

YS Copenhagen Liaison Office
Generatorvej 6A
DK-2730 Herlev, Denmark
Tel: 44 92 49 00

FINLAND

F-Musiikki Oy
Kluuvikatu 6, P.O. Box 260,
SF-00101 Helsinki, Finland
Tel: 09 618511

NORWAY

Norsk filial av Yamaha Scandinavia AB
Grini Næringspark 1
N-1345 Østerås, Norway
Tel: 67 16 77 70

ICELAND

Skifan HF
Skeifan 17 P.O. Box 8120
IS-128 Reykjavik, Iceland
Tel: 525 5000

OTHER EUROPEAN COUNTRIES

Yamaha Music Central Europe GmbH
Siemensstraße 22-34, 25462 Rellingen, Germany
Tel: +49-4101-3030

AFRICA

Yamaha Corporation,
Asia-Pacific Music Marketing Group
Nakazawa-cho 10-1, Hamamatsu, Japan 430-8650
Tel: +81-53-460-2312

MIDDLE EAST

TURKEY/CYPRUS

Yamaha Music Central Europe GmbH
Siemensstraße 22-34, 25462 Rellingen, Germany
Tel: 04101-3030

OTHER COUNTRIES

Yamaha Music Gulf FZE
LB21-128 Jebel Ali Freezone
P.O.Box 17328, Dubai, U.A.E.
Tel: +971-4-881-5868

ASIA

THE PEOPLE'S REPUBLIC OF CHINA

Yamaha Music & Electronics (China) Co.,Ltd.
25/F., United Plaza, 1468 Nanjing Road (West),
Jingan, Shanghai, China
Tel: 021-6247-2211

HONG KONG

Tom Lee Music Co., Ltd.
11/F., Silvercord Tower 1, 30 Canton Road,
Tsimshatsui, Kowloon, Hong Kong
Tel: 2737-7688

INDONESIA

PT. Yamaha Music Indonesia (Distributor)
PT. Nusantik
Gedung Yamaha Music Center, Jalan Jend. Gatot
Subroto Kav. 4, Jakarta 12930, Indonesia
Tel: 21-520-2577

KOREA

Yamaha Music Korea Ltd.
Tong-Yang Securities Bldg. 16F 23-8 Yoido-dong,
Youngdungpo-ku, Seoul, Korea
Tel: 02-3770-0660

MALAYSIA

Yamaha Music Malaysia, Sdn., Bhd.
Lot 8, Jalan Perbandaran, 47301 Kelana Jaya,
Petaling Jaya, Selangor, Malaysia
Tel: 3-78030900

PHILIPPINES

Yupangco Music Corporation
339 Gil J. Puyat Avenue, P.O. Box 885 MCPO,
Makati, Metro Manila, Philippines
Tel: 819-7551

SINGAPORE

Yamaha Music Asia Pte., Ltd.
#03-11 A-Z Building
140 Paya Lebar Road, Singapore 409015
Tel: 747-4374

TAIWAN

Yamaha KHS Music Co., Ltd.
3F, #6, Sec.2, Nan Jing E. Rd. Taipei.
Taiwan 104, R.O.C.
Tel: 02-2511-8688

THAILAND

Siam Music Yamaha Co., Ltd.
891/1 Siam Motors Building, 15-16 floor
Rama 1 road, Wangmai, Pathumwan
Bangkok 10330, Thailand
Tel: 02-215-2626

OTHER ASIAN COUNTRIES

Yamaha Corporation,
Asia-Pacific Music Marketing Group
Nakazawa-cho 10-1, Hamamatsu, Japan 430-8650
Tel: +81-53-460-2317

OCEANIA

AUSTRALIA

Yamaha Music Australia Pty. Ltd.
Level 1, 99 Queensbridge Street, Southbank,
Victoria 3006, Australia
Tel: 3-9693-5111

NEW ZEALAND

Music Houses of N.Z. Ltd.
146/148 Captain Springs Road, Te Papapa,
Auckland, New Zealand
Tel: 9-634-0099

COUNTRIES AND TRUST TERRITORIES IN PACIFIC OCEAN

Yamaha Corporation,
Asia-Pacific Music Marketing Group
Nakazawa-cho 10-1, Hamamatsu, Japan 430-8650
Tel: +81-53-460-2312

HEAD OFFICE Yamaha Corporation, Pro Audio & Digital Musical Instrument Division
Nakazawa-cho 10-1, Hamamatsu, Japan 430-8650
Tel: +81-53-460-3273



Yamaha Manual Library
<http://www.yamaha.co.jp/manual/>

U.R.G., Pro Audio & Digital Musical Instrument Division, Yamaha Corporation
© 2005 Yamaha Corporation

WE93810 506AP???.?-01A0
Printed in ?????