

EBONY-NEO

THE OWNER'S
MANUAL



EBONY-NEO
PIANO (DIGITAL)

samick 
SAMICK MUSICAL INSTRUMENTS CO., LTD
www.samickpiano.com

JMS1509.003

2015 SAMICK INTERNATIONAL MARKETING DIVISION

Before We Begin,

We would like to thank you for choosing the EBONY-NEO. We believe you invested a lot of time and effort to find out which digital piano would be most suitable for your playing environment and personal needs. We know there are many choices in the market, so, we are glad to meet you.

The most important thing we considered during the development of the EBONY-NEO was you, our customer. We imagine your smile every time you sit down to play the EBONY-NEO. It's that smile, the joy of creating music, that motivated us to build a piano of this caliber for you. Your satisfaction is always our #1 goal.



Where to put your EBONY-NEO



The EBONY-NEO was developed to be a contemporary looking, elegant, easy to play, great sounding piano. The function of this instrument is simple so players of any age or skill level will enjoy it.

We hope you enjoy your new EBONY-NEO piano. Our goal was to develop an instrument that's not only fun to play, but also adds to a lifestyle of creating music.

Your safety is important for us, so we encourage you to read the owner's manual thoroughly. Understanding the functions and precautions of the instrument will only add to your enjoyment of the EBONY-NEO.

Your digital piano and its technology offers you many advantages. It never needs tuning and few adjustments. Although much of the NEO is wooden, its design makes it versatile. You can place it on outside walls and it is less susceptible to the negative effects of humidity and temperature issues.

Try to keep the top of the piano free of framed photos and other items that might vibrate and rattle when the piano is played. Plants are also dangerous if water leaks or spills. Drinks should be kept away from pianos. Any liquid spill will damage the finish and possibly the inside. Hot cups will also leave marks on most finishes.

Care and maintenance of you cabinet



The finish on your piano is very durable and will keep it's beauty and luster for years to come. Maintenance is easy with a clean, slightly damp cotton cloth. Follow by drying off with a clean soft cloth. Do not use furniture polishes that contains silicone as they may negatively affect the finish. Avoid using aerosol polishes. The over-spray may land on parts of the piano to be avoided.

Clean the white keys with a slightly damp white cotton cloth (colored cloths may stain the keys). You can lift the natural/white keys up slightly, approximately 3/4 inch, to reach them properly for cleaning. Try to use a different cloth for the sharp/black keys to prevent the black polish from staining the white keys. The piano may be damaged if water runs down the sides of the keys so ensure you only just dampen the cloth. Finally, dry off any excess moisture and leave the lid open to air.

Contents Guide

1. *Safety Information*
2. *What comes with EBONY-NEO*
3. *Overview*
4. *Detail View*
5. *Quickstart*
6. *Basic Operation*
 - Demo Songs*
 - List of Voice*
 - Voice Select*
 - Voice Combination*
 - Metronome*
 - Adjusting BPM*
 - Time signature change*
 - Metronome Volume Control*
7. *Effects*
 - Reverb*
 - List of reverb effects*
 - Activate reverb effects*
 - Reverb select*
 - Chorus & other effects list*
 - Effects select*
8. *Record & Playback*
 - Entering Record Mode*
 - Playback Recording Files*
 - Delete Recording Files*
9. *Configuration*
 - Configuration Mode*
 - Table of setting Parameter*
 - Setup*
10. *Useful Information*
 - Explanation of Terms*
 - Warranty*
 - Troubleshooting*
 - Specifications*

EBONY-NEO





1. Safety Information

NOTE The manufacturer cannot be held liable for injury to persons or damage to property resulting from incorrect use of the device!

Only use your digital piano in accordance with the instructions given here!

Explanation of Symbol

In this user's manual the following symbols are used to denote risks and advice:

Degree of risk	Symbol	Signal word	Definition
Serious injuries		WARNING	Death or serious injuries may be the consequence of failure to observe the safety instructions
Serious injuries from electricity			Supplement to the labelling of the risk from electricity
Slight injuries and damage to property		CAUTION	Slight injuries and/or damage to property may be the consequence of failure to observe the safety instructions
Note		NOTE	Notes on how to avoid damage to people, environment and/or equipment
Tip		TIP	Tip on the use of the digital piano

Correct Use

The digital piano is intended for making music in dry premises. Equipment for audio playback (as input or output) or for data communication may be connected. The relevant technical specifications must be observed (Technical Data). The electrical connection must only be carried out to properly installed power supplies. The supply voltage of the rating plate must be the same as the supply voltage of the country of use. The digital piano is only to be used in the condition as delivered. Conversions are not permissible. The digital piano must be set up on safely weight-bearing, stable and even flooring or platforms appropriate for the weight.

Misuse

Avoid use outdoors in wet or damp environments.
 Connection to incorrect supply voltage or not properly installed electrical supply voltages.
 Use in the immediate vicinity of electrical or electronic devices such as stereo systems, television sets, radios or mobile phones. These devices can cause disturbances and impair the tone quality.
 Connecting leads that are too long can likewise impair the tone quality.
 Transporting and setting up with strong vibration, dust exposure and with strong heat effect (e.g. in vehicles or in direct sunshine).



The manufacturer cannot be held liable for damage for the following reasons:

- Non-compliance with the safety instructions
- Improper handling
- Using with unsuitable in/output devices etc. or communication devices

Safety Precautions

Failure to follow the safety precautions given here may have serious consequences

Serious injury or even lethal accidents
Electrocution
Short circuits
Damage
Fire

Further risks resulting from improper use are conceivable, therefore this is not a conclusive list.



Danger of death by electrocution



Even low electric currents can lead to serious injuries and death!
There are no user serviceable parts inside your piano. Please do not open
Never use damaged power cables.
Lay the power cables so that there is no risk of damage.
Liquids and fluids are a shock hazard and should be avoided in the vicinity of electronic products like your digital piano
Never clean the digital piano with a wet cloth.
Never plug in or unplug with wet hands. Never pull on the cable, it may be damaged.
If liquid accidentally gets into the digital piano, unplug it immediately.
Then have the digital piano checked by your customer service.
Switch the digital piano off or unplug it if:



If something unusual occurs

In the rare event of a sudden loss of sound while in use or an unusual smell or smoke, turn off and/or unplug immediately.
It is essential to have the digital piano checked by your customer service.



Fire Prevention

Avoid open flames like candles on your piano. They can be a fire hazard.
Never put open flames down on the digital piano!



Damage to the digital piano

Please use only the power adapter provided with your piano and only use an outlet that supplies the required voltage and specifications noted on the power adapter label.
Never lay the power cable in the vicinity of heat sources such as radiators or radiant heaters.
Do not over-bend or kink the power cable and do not damage it in any other way.
Lay the power cable in such a way that no one will stand on or trip over it or something can roll over it.
Do not place any objects on the power cable.
Check the mains cable at regular intervals and remove any dust or dirt that may be on it.

2. What Comes With EBONY-NEO

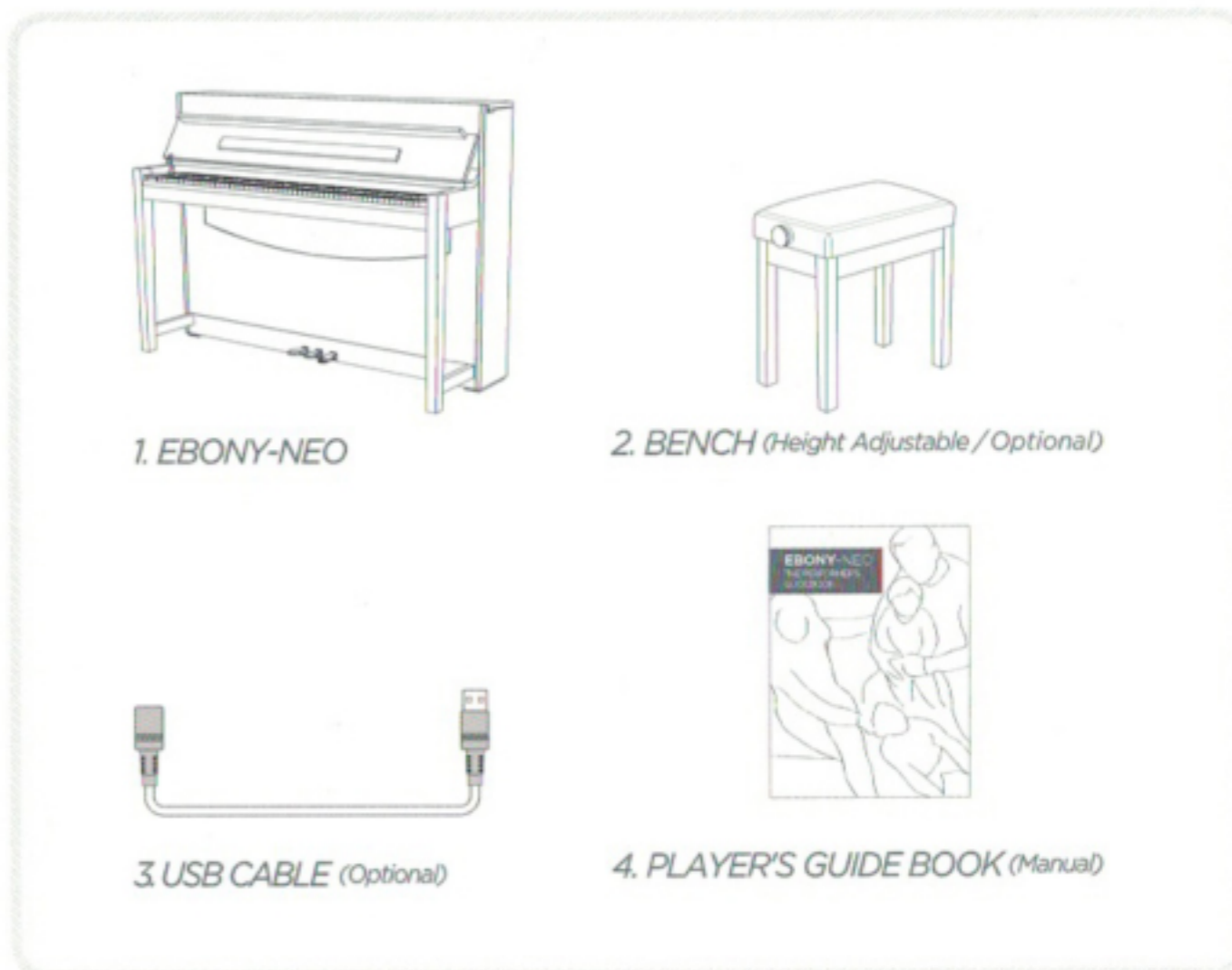

1. EBONY-NEO

2. BENCH (Height Adjustable / Optional)

3. USB CABLE (Optional)

4. PLAYER'S GUIDE BOOK (Manual)



Use discretion when using this or any electrical appliance during a thunderstorm.



Thunderstorms may create surges that can damage electrical equipment. During thunderstorms or long periods of non-use may want to unplug your piano.

Disposal

If your digital piano has become obsolete, take your device to the collection point of your local waste management service (e.g. disposal business, recycling center).



The adjacent symbol means that the old device must be disposed of separately from household waste. Under the Act on Electrical and Electronic Equipment owners of old equipment are legally obliged to put old electrical and electronic equipment in a separate waste collection.

Please help and make your contribution to the protection of the environment by not putting your old equipment in with the household waste.



3. Overview

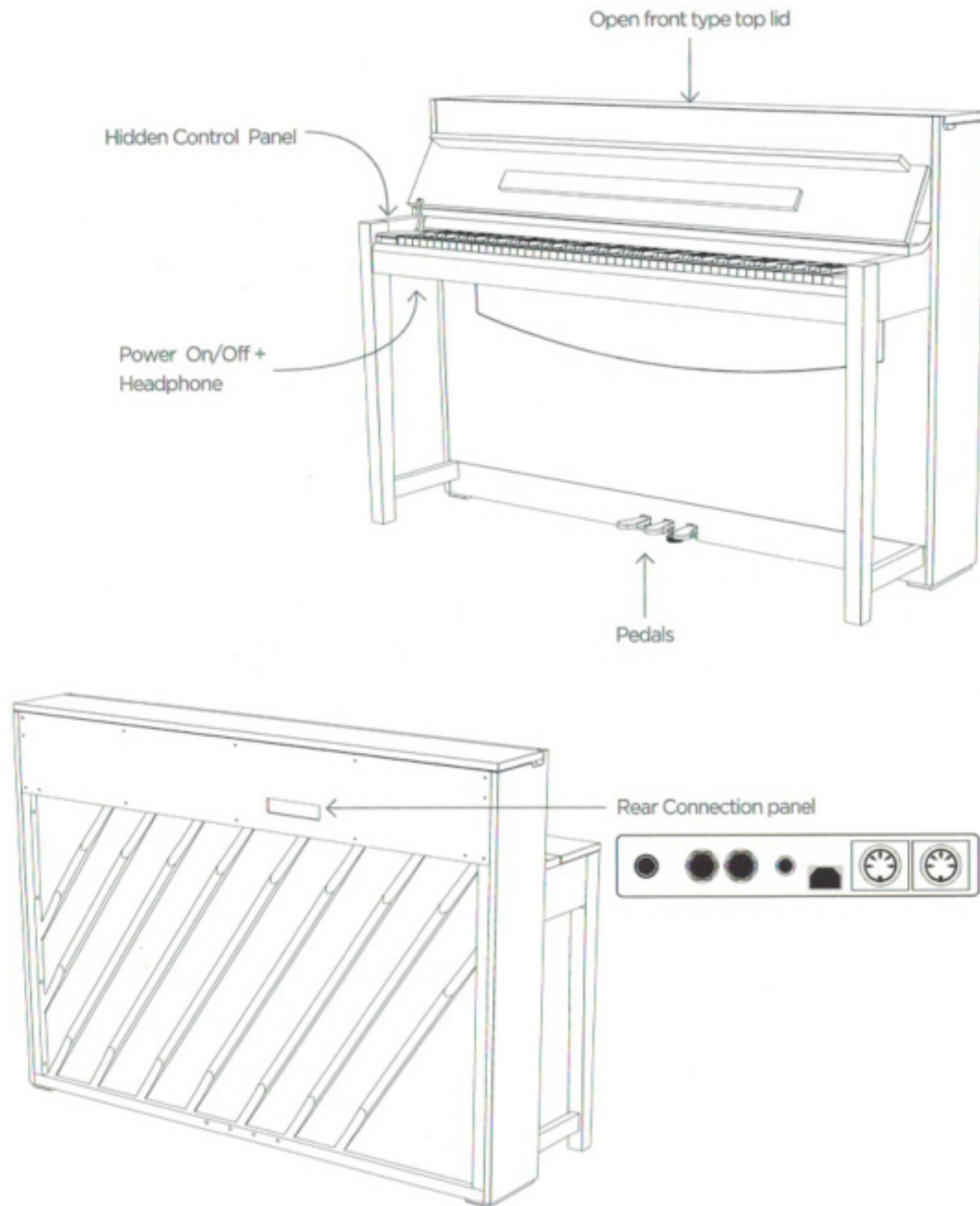

4. Detail View

Hidden Control Panel

You might be confused or surprised when you see the EBONY-NEO's hidden control panel for the first time. The primary goal from the beginning was an authentic appearing acoustic piano. We tried to remove everything labeling this product as a digital piano from the EBONY-NEO's exterior. Thanks to the hidden control panel, you can enjoy EBONY-NEO's beautiful cabinet design without distraction of plastic buttons, knobs and LEDs even when its turned on.

- ① **1. LED DISPLAY**
This provides information to the programmed settings
- ② **2. CURSOR KEYS**
Navigate the functions and make new settings

* UP/DOWN button : Mostly for changing the setting value
* LEFT/RIGHT button : Mostly for shifting the function select
⚠ Without any other function engaged the cursor keys will directly effect the metronome (BPM) speed
- ③ **3. VOLUME**
Set the volume
- ④ **4. VOICE**
Choose the different sounds of your digital piano (Page 21)
- ⑤ **5. METRONOME**
Switch the metronome on or off (Page 23)
- ⑥ **6. DEMO**
Push the Voice- and Metronome-keys simultaneously, to reach the DEMO-Function (Page 20)
- ⑦ **7. REVERB**
Change the simulated area or room sound (Page 25)
- ⑧ **8. CHORUS**
Add special effects to the sound (Page 27)
- ⑨ **9. FUNCTION**
Activate the Function-Menu, to make various settings (Page 32)
- ⑩ **10. REC**
Start the recording (Page 29)
- ⑪ **11. PLAY/STOP**
Start/Stop the playback of the recorded play (Page 30)
- ⑫ **12. SONG SELECT**
Push the REC- and Play/Stop-Keys to choose a recorded song (Page 29)

Rear Connection Panel

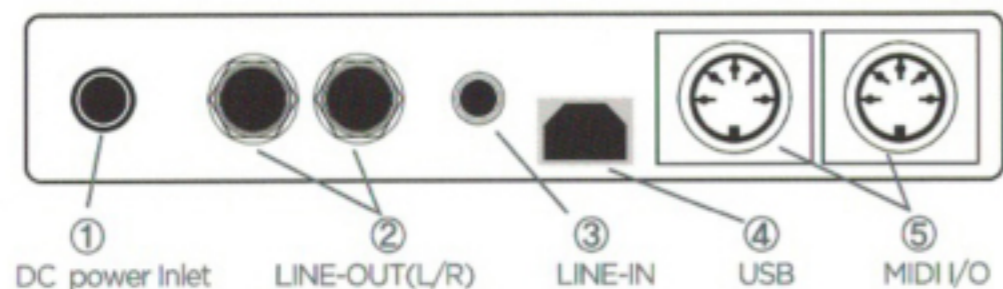

1. DC POWER INLET

2. LINE-OUT

You are able to connect with your amplifier system or recording devices (Left & Right Channel).

3. LINE-IN

Connect an external audio devices (e.g. MP3 player) You can hear the sounds (or music) such as accompaniment for practice together with your piano play.

4. USB

Connect to your USB-MIDI compatible device via this connector.

5. MIDI I/O

Connect MIDI devices. For more information about MIDI connection, please refer to page 35 & 36.

Power Switch & Headphone

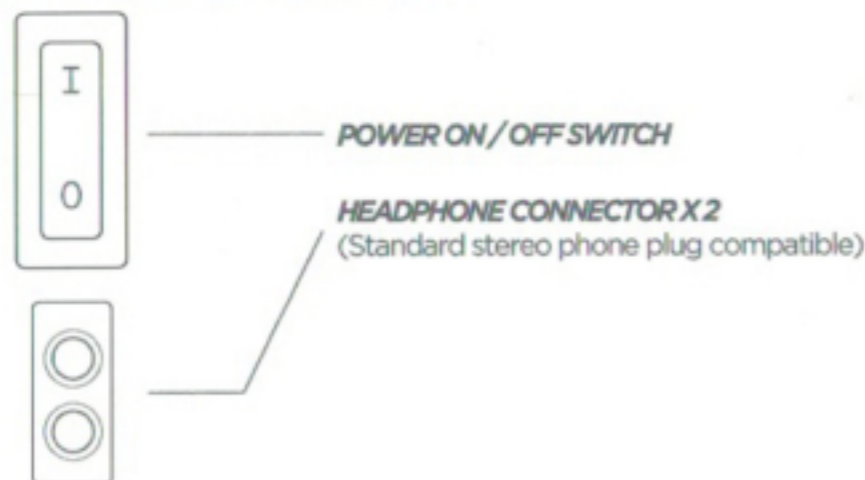

<Bottom of key bed>



EBONY-NEO's high resolution sound system will turn off when you plug in your headphones and will come back on when you unplug. Make sure to set the volume level less than a mid range before you pull out the headphone jack.

Pedal

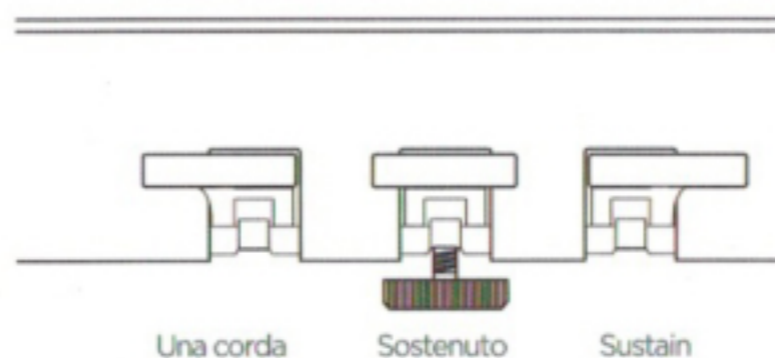

UNA CORDA PEDAL (LEFT)

The una corda pedal (soft pedal) simulates moving the piano action closer to the strings. That makes the sound of your digital piano quieter and softer.

SOSTENUTO PEDAL (CENTER)

The sostenuto pedal functions in the same way as the damper pedal. If it is pressed while you are playing a note or a chord, only this note or chord is held until the pedal is released again. Unlike the damper pedal the notes/chords played after are not held.

DAMPER/SUSTAIN PEDAL (RIGHT)

The damper/sustain pedal simulates the removal of the dampers from the strings of an acoustic piano. Notes that you play after pressing the damper/sustain pedal sound considerably longer. With this pedal a half-pedal technique is possible.

Note : Leveling the pedal

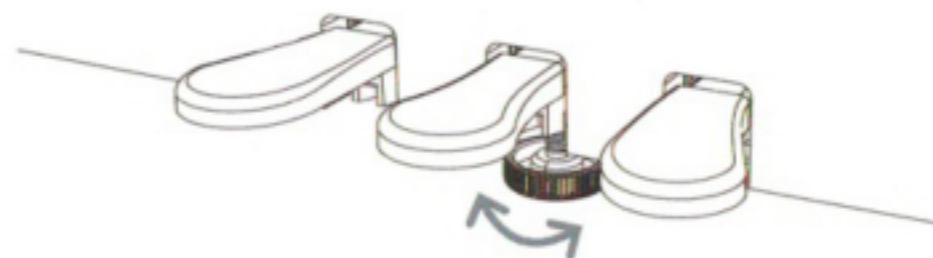

1. Place your EBONY-NEO on the designated position.
2. Turn the support screw bottom of the pedal board until it reaches to the floor.
3. Make sure to support screw equally leveling with the floor to prevent pedal noise or damages.

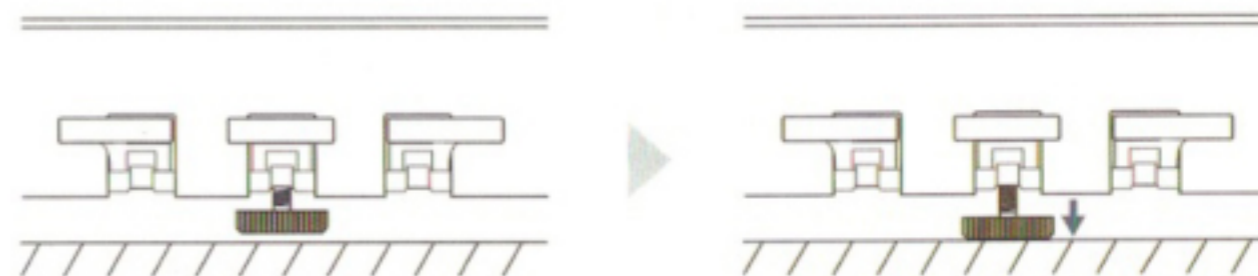

5. Quickstart

To turn on, locate the volume slider under the panel on the left key-block and set to its middle position before starting.

Then locate the power switch under the far left side of the keyboard and flip it on.

Unlike conventional digital pianos, EBONY-NEO has hidden control panel on the left key block.

Gently lift up the control panel's cover, you will find the simple but intuitive control panel with LED display.

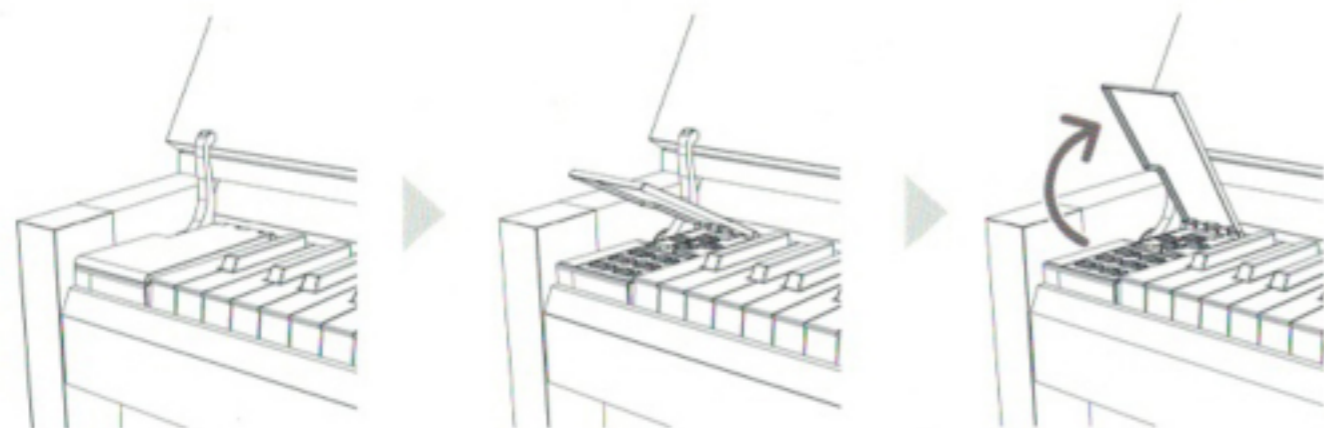
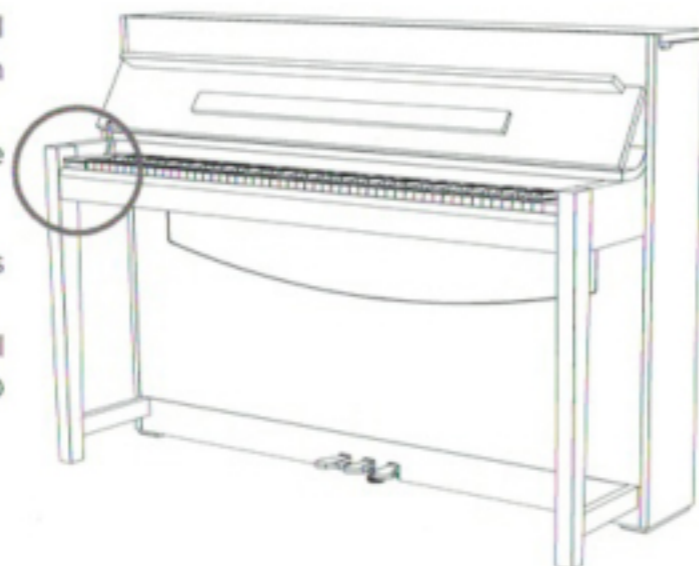

EBONY-NEO's parameters will reset when the piano is turned off and on with the exception of balance, brilliance and volume.

A pleasant surprise you'll notice from the start

A great deal of effort and time was spent with our German engineering team placing just the right speakers in just the right places to give you an unparalleled acoustic piano experience from your "digital" piano.

By the way,

Great acoustic pianos often have lids to be opened to enhance and direct their sound. Your EBONY-NEO is no exception. Open the lid and listen to the wonderful piano sound.

Open the lid and listen to your wonderful piano



1. Notice the beautiful cabinet design and craftsmanship. Slip your hand into the sculptured opening, lift and set the prop to hold it open.
2. When you open the top lid with one hand, you will find short prop to support the top lid.
3. Rotate the prop about 90 degrees counter clock wise and then slowly lift down the top lid onto tip of short prop which will hold the top lid from now on.



The lid is not designed to fully rotate open without possible damage and safety issues
 Never leave the top lid fully open for your safety
 Make sure to close top lid after play

“The Unexpected beauty of an acoustic piano.”

EBONY-NEO



The Remarkable Functions and features of a Digital Piano

6. Basic Operations

Your Samick digital piano is designed to be easy and intuitive to operate. Please follow each basic operation, step by step as described and illustrated.

DEMO Songs

There are 10 internal songs your NEO will play for you to demonstrate each of the sounds your digital piano provides.

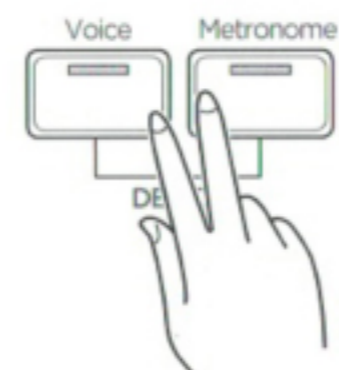

1. Press the 'Voice' and 'Metronome' buttons together at once.
The red indicators of both buttons will flickering.



2. The LED display indicates the demo song number which are the same of voice number. (10 demos)

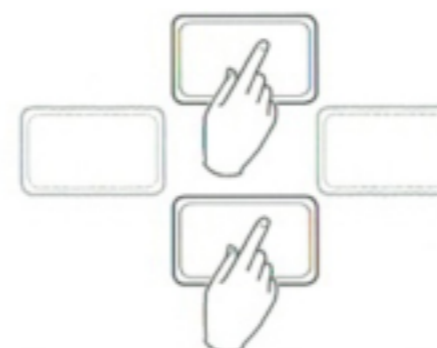

3. Press 'Up' or 'Down' button to select demo song number you want to enjoy.

** Please refer to voice list (next chapter) for your convenience.

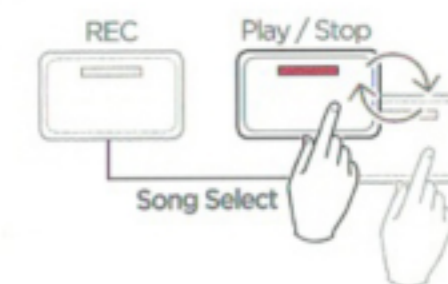

4. Press the 'Play/Stop' button after select demo song number and then it will played. Also, it stopped when you press 'Play/Stop' once again.

List of Voices (Sounds)

The EBONY-NEO has 10 voices and you're able to combine two different voices at once during your play. First of all, please refer to below list of voices and indicated numbers for your convenience.

	PIANO 1		ORGAN 1
	PIANO 2		ORGAN 2
	HARPSICHORD		STRINGS 1
	E-PIANO 1		CHOIR
	E-PIANO 2		VIBRAPHONE

Voice Select

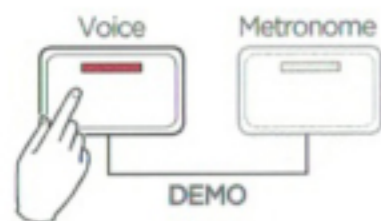

1. Press the 'Voice' button to activate voice function and it will indicate with red which is enabled.

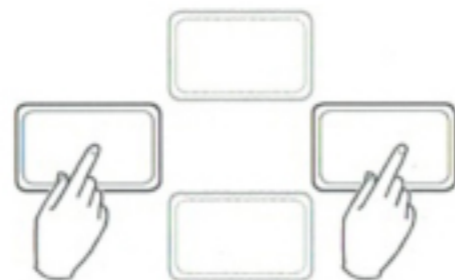

2. Press 'Left' or 'Right' cursor key to select voice number you want to enjoy.
*Please refer to list of voices table.

Voice Combination (Layering)

The EBONY-NEO has 10 voices and you're able to combine or "layer" two different voices at once during your play which means you can play two different instrument and hear them simultaneously.

First of all, please refer to list of voices and indicated numbers for your convenience.



1. Select the main voice as explained on voice select. (i.e.) Piano 1 (selected for main voice)

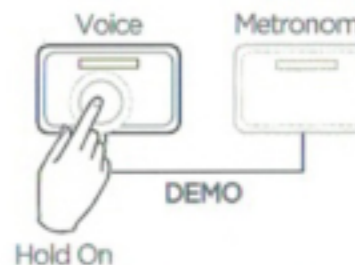

2. Press and hold the 'Voice' button until you finish the 2nd voice selection.

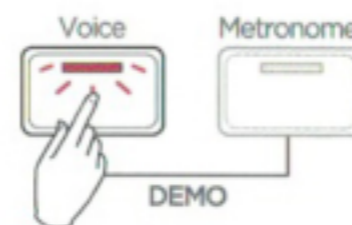

3. The LED on the 'Voice' button will flicker as the display shows you the selected main voice



4. Press 'Left' or 'Right' button to cycle through available voices and select 2nd voice sound that you want to play as combination. After selecting 2nd voice, you can enjoy 2 different voices simultaneously as your play.



You are able to adjust each voice's volume level and balance with 'Balance Setting' function which is described on page 34

The 'Voice' LED will continue to flash during voice combination mode. It will stop flashing when you press the 'Voice' button once again.

Metronome

The EBONY-NEO has a built-in metronome which helps you during your play to find and hold the precise tempo.

7 different time signatures are selectable (1/4, 2/4, 3/4, 4/4, 5/4, 3/8, 6/8)

You are also able to set BPM (Beat Per Minute) between 32 - 250

Metronome volume control is also available

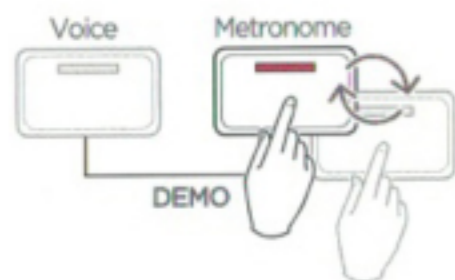

Press the metronome button to turn on.
The light will turn on.



Press again to turn off at which time the light will turn off.

Adjusting BPM

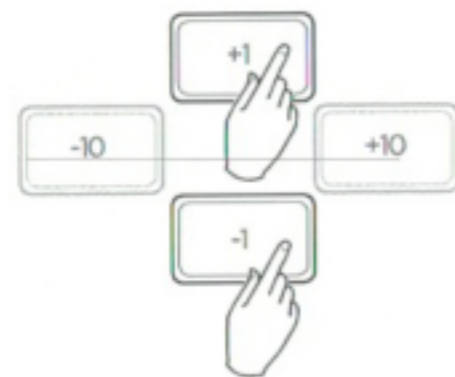

After activating metronome or whenever no function is selected. (No function buttons will be lit)
Press the 'Up' or 'Down' cursor button to increase or decrease its tempo value in 1 level.
In the same manner, you can adjust tempo value in increments of 10 using the 'Left' or 'Right' cursor buttons.
* Adjustable BPM range of 32 to 250

Changing the time signature settings

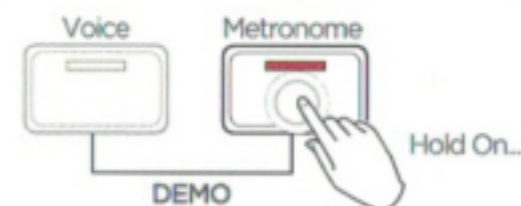

1. Press and hold the 'Metronome' button until you finishing its setup change.

2. The display will indicate current time signature.

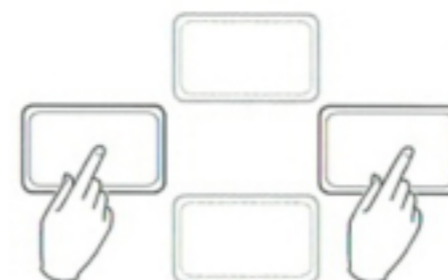

3. Press 'Left' or 'Right' cursor key to find your desired time signature.

7 time signatures selectable
1-4, 2-4, 3-4, 4-4, 5-4, 3-8, 6-8

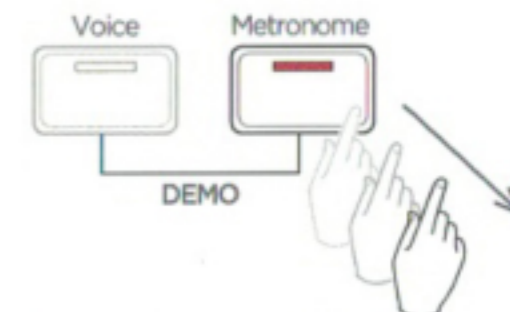

4. Release the 'Metronome' button after making your time signature selection.



Metronome Volume Control

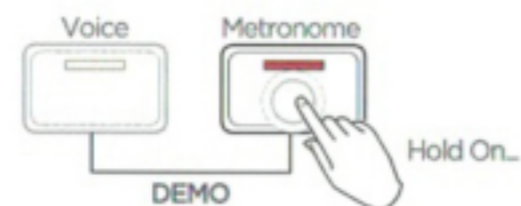

1. Press and hold the metronome button while you change its settings with the left/Right cursors.

2. The display will indicate current time signature.

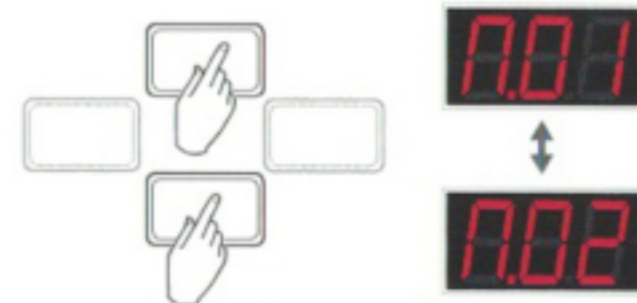

3. Press 'Up' or 'Down' cursor key to find your desired metronome volume level from 1 to 20.
The LED displays N.01 - N.20 metronome volume level.

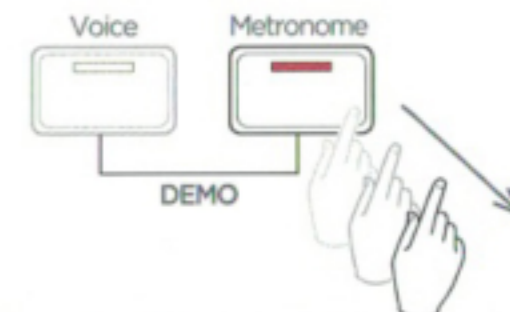

4. Release the 'Metronome' button after setup.



6. Basic Operations

Reverb

The reverb effect simulates the way sound is heard in different environments resulting from the size, shape, and reflective materials of the enclosure or space. It allows you to enjoy your music as if you are playing a concert hall or small room.

List of Reverb Effects



Simulates the sound in a furnished lounge



Simulates the sound in a medium sized empty room



Simulates the sound on a live stage



Simulates the sound in a concert hall



Simulates the sound in a cathedral

Activate Reverb Effects

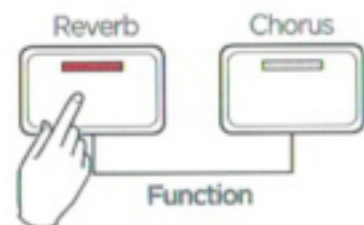

Press the 'Reverb' button to activate and red LED will illuminate.



The Reverb will deactivated when you press its button once again. (LED will turned off)

Reverb Select

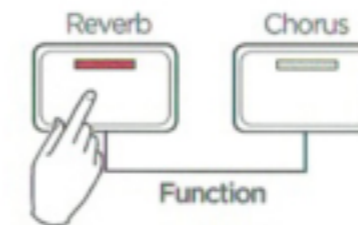

1. Press the 'Reverb' function button and the red indicator light will turn on

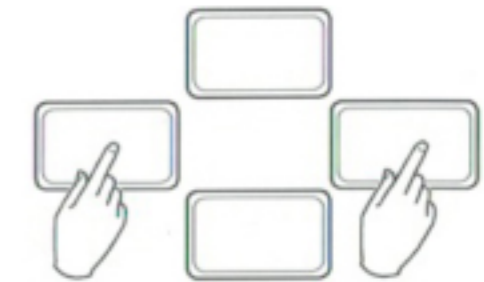

2. Press 'Left' or 'Right' cursor key to select reverb effects you want to enjoy.

* Please refer to list of reverb effects



You can adjust reverb length and time of 'Reverb' effects with 'Up' and 'Down' button which are able to increase or decrease between 1 to 20.

The change of reverb effects and intensity will take effect right after its adjustment.



Some voices are programmed to activate reverb or chorus effects in order to make its sound and tone more realistic and dramatic.

You are able to control or adjust those voice's effects as described in this manual.

The effects setting that you change will remain until you turn off the EBONY-NEO. Most of settings will be restored as factory setup when you turn on the EBONY-NEO.

Chorus & Other Effects



CHORUS 1

The chorus effect simulates the natural warmth that happens in sound when multiple instruments of similar pitch and timbre are sounding together



CHORUS 2

More intense than 'Chorus 1'.



FLANGER

Flanger makes a time lapse effects to its sound and varies tone pitch over an original sound.



PHASER 1

Phaser effects will gives the impression with slowly tenderized sound.



PHASER 2

More intense than 'Phaser 1'.



TREMOLO 1

'Tremolo 1' varies the volume of sound in rapid repetition.



TREMOLO 2

More intense than 'Tremolo 1'.



ROTARY

It will simulates a circulating sound from left to right speakers or vice versa.
(it has no intensity level, just on or off when you select)

Effects Select

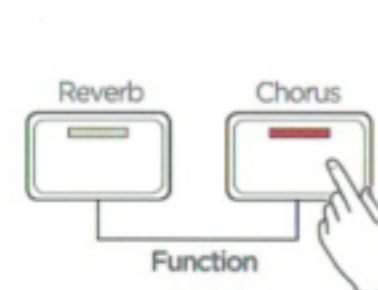

1. Press the 'Chorus' button to enable and you are able to notice it with illuminated red LED.

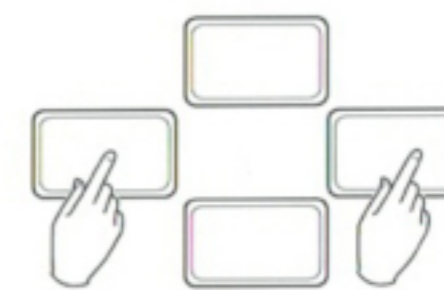

2. Press 'Left' or 'Right' cursor key to select the effects you want to enjoy.

* Please refer to list of chorus effects table (Page 25)

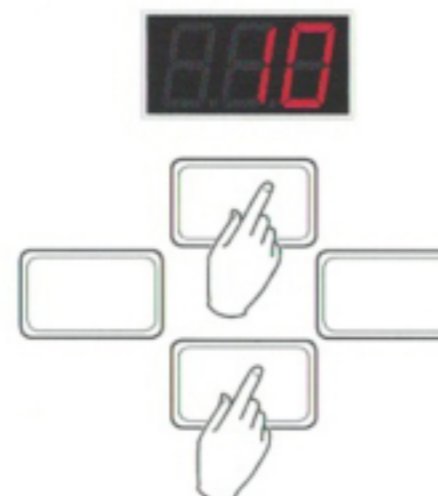

You can adjust the effects intensity with 'Up' and 'Down' button which are able to increase or decrease between 1 to 20. The change of effects and intensity will take effect right after adjustment.

8. Record & Playback

Your EBONY-NEO is able to record and save 3 different piano performances into 3 memory spaces. You can record and playback

Entering Record Mode

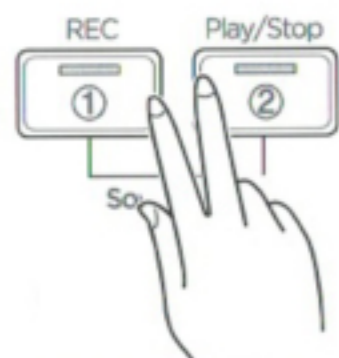

1. Press & hold the 'REC' button first and press the 'Play/Stop' button to activate Recording feature.



2. Select a memory (Song, "SN") location to save your performance with using the cursor 'Up' and 'Down' buttons
* Memory (Song) locations are available from SN.1 to SN.3

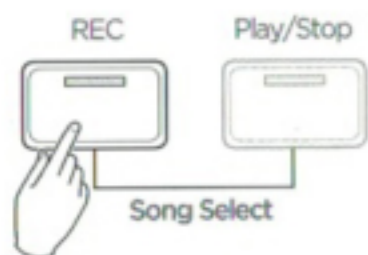

3. Press the 'REC' button again to start the recording into your selected location.

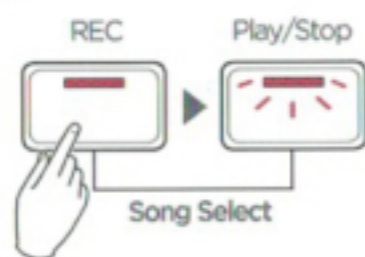

4. When you press the 'REC' button for recording, the LED light on the 'Play/Stop' button will flash which indicates it's ready to record.



5. Recording will begin automatically when you start play from the first note and the LED displays scrolling small dots.

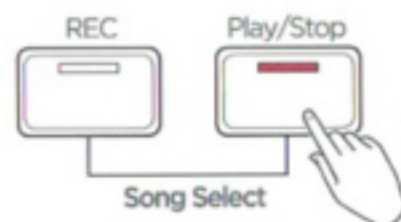

6. Push the 'Play/Stop' button to stop recording. Your recording will be automatically saved to the location you selected.

Playback Recording Files

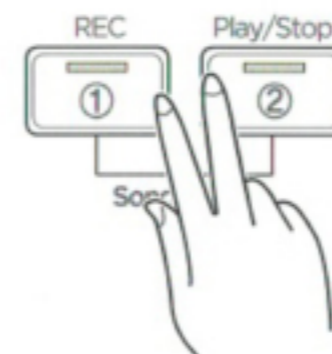

1. Press & hold the 'REC' button first and press the 'Play/Stop' button to select recording feature.



2. Select the file you want to playback with 'Up' and 'Down' buttons.
* There should be recorded play that you were select.



3. Press the 'Play/Stop' button to start playback. You can stop the playback if you press 'Start/Play' button once again.
(The red indicator remains on during playback)



During the playback, you can play along with playback allowing you to use recorded play as accompaniment.

Delete Recorded Files

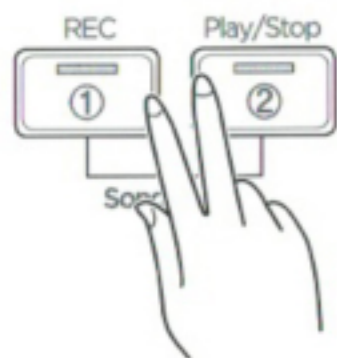

1. Press & hold the 'REC' button first and press the 'Play/Stop' button to activate the recording mode.

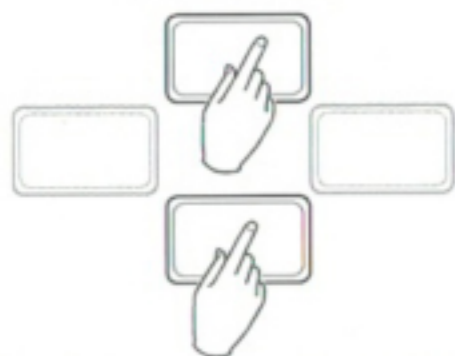

2 Select the file you want to delete with 'Up' and 'Down' cursor.

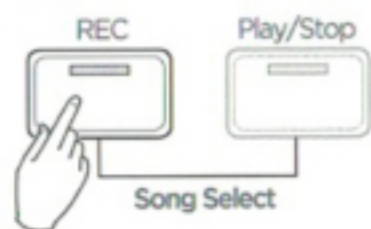
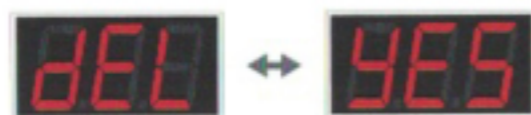

3. The display shows "[DEL], [YES]" if you press the 'REC' button after selecting a memory (song "SN. ?") location. You are being ask to either confirm or cancel your delete request.

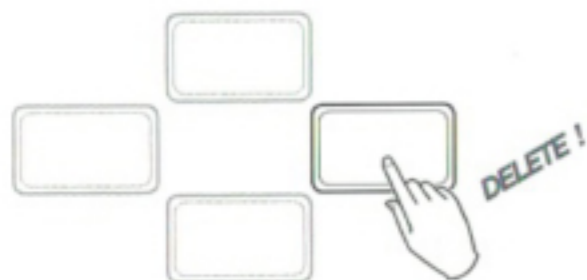

4. Press 'Right' cursor key to confirm deletion.



4-1. Press 'REC' again to cancel the delete command

◆ To select different memory location or exit delete mode just press & hold the 'REC' button and then press the 'Play/Stop' button which returns you to the memory select mode.

9. Configuration

In this chapter, you will learn how to control, adjust, activate and setup the various functions and features that allow you to tap into the full potential of your digital piano.

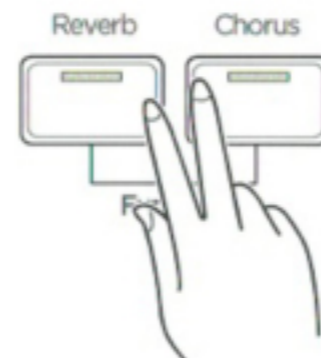

1. Press 'Reverb' and 'Chorus' buttons together to enter configuration mode.



2. LED display will blink with current setting level.



3. Press the 'Left' or 'Right' cursor key to select setup parameter you want to change.
* Please refer to table of setup (Page 33)

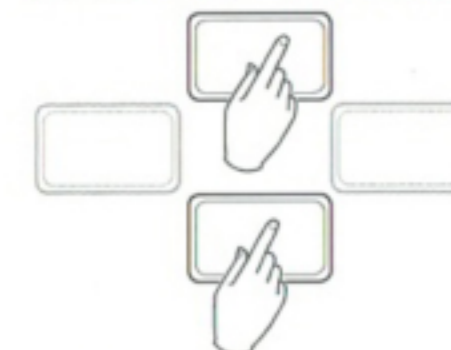

4. Use the 'Up' and 'Down' cursor key to change the level or activation once you've select the setup.

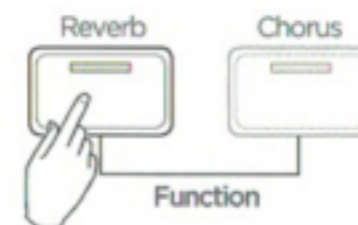

5. Press the 'Reverb' key to finish the setup

Table Of Setting Parameter

	TRANSPPOSITION [-6 to 6]		TUNING TEMPERAMENT [Equ/MAJ/Min/Pyt/NEA/ N53/Bg3]
	FINE TUNING [270 to 530 (5 steps)]		STRING RESONANCE [0 to 20]
	TOUCH SENSITIVITY [MED/LIT/Hrd/OFF]		DAMPER RESONANCE [0 to 20]
	VOLUME BALANCE (Dual-Voice) [1-5 to 5-1]		KEY NOTE TUNING CHANGE [C/C#/d/d#/E/F/F#/G/G#/A/ A#/b]
	BRILLIANCE [-6 to 6]		PIANO MODE [ON / OFF]
	LOCAL CONTROL [ON / OFF]		MIDI TRANSFER CHANNEL [1 to 16]
	DATA TRANSFER [ON / OFF]		



All the setup parameters are able to change or activate follow through the 'Configuration-Mode' and please refer to Page 32
All configuration settings will return to factory settings when you turn the piano off or on



TRANSPPOSITION
[-6 to 6]

1. Transposition

This function allows you to change the overall pitch of your piano. This can be used to adjust to the pitch of your piano up or down. This can be used to adjust pitch to match to another instrument or adjust to the vocal range of a singer without having to change to another key.

You can move the pitch 6 half steps up or down with factory setting at zero (0)



FINE TUNING
[270 to 530 (5 steps)]

2. Fine-Tuning

If you think you need fine tuning of 'EBONY-NEO' in order to get an optimum performance what you are looking for is available by adjusting the level 270 to 530 in 5 steps.



TOUCH SENSITIVITY
[MED/LIT/Hrd/OFF]

3. Touch Sensitivity

You can adjust the keyboard sensitivity from hard, medium, soft, or off with this function.

The following sensitivity levels are available :

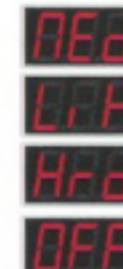

MED : Medium sensitivity (standard setting)

LIT : Highest sensitivity which creates a loud tone with lowest strength of key play

Hrd : Lowest sensitivity which requires relatively high strength of key play

OFF : No matter how weak you touch, identical loud tone will created
(Useful option for 'Organ' voice play)



VOLUME BALANCE
(Dual-Voice)
[1-5 to 5-1]

4. Volume Balance (Dual-Voice)

As it described in previous chapter on 'Voice Combination' (Page 22), you are able to adjust the balance of volume for each voice separately with 'bal' setup. It's not related with speakers on the left and right rather related with 1st and 2nd voice's sound volume.

You can setup volume ratio from 1:5 to 5:1 (1st vs 2nd voice volume)





BRILLIANCE
[-6 to 6]

5. Brilliance

If you want to hear even more brighter and clear sound from 'EBONY-NEO', you might be able to find your preferred sound characteristic to change this setting from -6 to 6 level.

It emphasizes and adjusting an EQ setting parameter more on high frequency.



LOCAL CONTROL
[ON / OFF]

6. Local Control

This will kill the built-in speaker system when you connect through MIDI -OUT to your external devices.

It will help you to create or edit with your MIDI workstation without any interruption from 'EBONY-NEO'.

(If you are not interested in MIDI connection, you may forget about this function.)



DATA TRANSFER
[ON / OFF]

7. Data Transfer

This will indicate whether the information about a MIDI data is transferred to an external MIDI device connected via MIDI OUT.

(If you are not interested in MIDI connection, you may forget about this as well.)



TUNING TEMPERAMENT
[Equ/MAJ/Min/Pyt/
NEA/N53/Bg3]
[1:5 to 5:1]

8. Tuning Temperament

A temperament is a system of tuning which slightly compromises the pure intervals of just intonation in order to meet other requirements of the system.

Tempering an interval involves the deliberate use of such minor adjustments (accepting the related destabilization) to enable musical possibilities that are impractical using just intonation.



The most widely known example of this is the use of equal temperament to address problems of older temperaments, allowing for consistent tuning of keyboard and fretted instruments and enabling musical composition in, and modulation among, the various keys.



STRING RESONANCE
[0 to 20]

9. String Resonance

String resonance occurs in an acoustic piano when strings will sympathetically vibrate with others causing a nuanced piano sound that can be more natural sounding.



DAMPER RESONANCE
[0 to 20]

10. Damper/Sustain Resonance

Damper resonance occurs in acoustic pianos in varying degrees and can sometimes give the impression of a more natural sounding piano.



KEY NOTE TUNING CHANGE
[C/C#/d/d#/E/F/F#/G/
G#/A/ A#/b]

11. Key Note Tuning Change

In addition to the 'Tuning Temperament' (Page 35), you also change the reference tone of the tuning.



PIANO MODE
[ON / OFF]

12. Piano Mode

In this setup, you can determine how the signals of channel 1 & 2 are reproduced when you connect through MIDI-IN.

If the piano mode is On, the channels 1 & 2 are reproduced with piano effects, if a piano sound is selected.

The chorus effect is not available for channel 1 & 2 during piano mode activating.

For channel 3 to 16, no piano effect is available but the GM chorus is available.

If the piano mode is Off, the piano effect is not available for any of 16 MIDI channels but the GM chorus effects can be added for all channels.



Standard setup is 'ON' for piano mode and automatically steered by the signal output instruments.



MIDI TRANSFER CHANNEL
[1 to 16]

13. MIDI Transfer Channel

This will allow you to assign MIDI data transfer channel from 1 to 16 for MIDI-IN & OUT. Depend on your assigned data transfer channel which is for the highest notes and the next higher channel will carry the lower or dual notes for data transfer. (i.e.) If you set channel 4 as MIDI data transfer channel, it carries higher notes and the channel 5 will transfer lower notes.

10. Useful Information

At this point we would like to explain to you a few terms that are used in our user manual. In addition, we explain the special features of your digital piano.

Explanation of Terms

MIDI

Musical Instrument Digital Interface is a data transfer protocol. With this, musical control information is transferred between electronic instruments such as digital pianos, keyboards, synthesisers, drum computers or even PCs or laptops. To exchange this control information, the instruments/computers require MIDI connections and a link must be established between them. There are different MIDI connections with various functions: MIDI-IN (input), MIDI-OUT (output) and MIDI-THRU. The last one routes received data unaffected via the MIDI input to another MIDI device.

i.e.) If a key on the digital piano is pressed, small digital data packets are output at the MIDI output (MIDI-OUT) of the digital piano. The data packets contain information about the pitch, the strike force as well as the duration of the keystroke. The data packets output can be e.g. recorded, stored, played back on the computer and also be made visible as notation on the screen if a corresponding program is available. Recorded MIDI data must normally be first sent to a MIDI instrument, i.e. for example a digital piano to make them audible.

GM

General MIDI (MIDI in short) standardises considerably more than the general MIDI standard. The latter is a hardware and protocol specification. General MIDI also specifies content. For this, GM sets a minimum standard for the assignment of the instruments to the 128 program places. According to GM, a compatible sampler must be able to generate 24 sounds simultaneously. Furthermore according to GM further control parameters are defined, such as e.g. effect control.

GENERAL MIDI SOUNDS

Sounds or instruments in accordance with the specifications of the General MIDI standard.

REVERB

The device simulates a room situation. This sound simulation is already preconfigured for some sounds to make them seem more realistic.

CHORUS

The chorus effect adds a further note that is scarcely audibly out of tune behind the notes played. This makes the note fuller and more natural.

SAMPLES

Samples are note recordings of instruments. The sounds of the instruments are recorded and saved individually. Now play a note on the keyboard of the digital piano, the corresponding recordings are played this way.

POLYPHONY

For electronic instruments the term polyphony designates how many sounds or notes can be played back simultaneously. The more notes that can be played back simultaneously the more natural the instrument sounds.

Warranty

The dealer where the device was bought gives a warranty for material and manufacture of the device for 3 years from purchase.

In the event of a fault the buyer has in the first instance only the right to supplementary performance. Supplementary performance includes either rectification or supply of a replacement product.

Equipment or parts exchanged become the property of the dealer.

The buyer must inform the dealer immediately about any faults identified. The proof of the warranty claim must be established by a correct confirmation of purchase (proof of purchase, or if applicable invoice).

Damage arising from incorrect handling, operation or storage as well as by force majeure or other external influences, does not fall under the warranty, nor in addition does the use of consumer items such as e.g. rechargeable batteries, strings, skins or seals.

If you suspect you have a claim under the warranty with your device, contact your dealer during normal business hours.

Trouble shooting

If malfunctions occur, with the tips listed here you can try to find and remedy the fault yourself. If you have no success please contact your specialist dealer.

Defect	Possible cause and solution
The device will not turn on	<ul style="list-style-type: none"> · Make sure that the power adapter is plugged into to a functioning outlet and plugged into the piano. · Be sure the wall outlet is not switched off from a wall switch.
Clicking noise when switching on/off	<ul style="list-style-type: none"> · A small sound will occur as the piano powers on or off. This is normal.
Static noise comes from the speakers during operating	<ul style="list-style-type: none"> · Sometime other electronic products can create noises. · If there are other devices in close proximity try increasing distance from the piano, switch off other devices, etc.
The sound is much too quiet or cannot be heard at all.	<ul style="list-style-type: none"> · Check the volume control. · Make sure there are no headphones plugged in. If so, Unplug.
The pedals do not function correctly	<ul style="list-style-type: none"> · Please contact your local dealer or distributor for help.

SAFETY PRECAUTIONS FOR HANDLING THE MAIN ADAPTOR



CAUTION

All necessary safety information in chapter 1 applies to the mains adapter. To connect the mains adapter use an easily accessible mains socket so that you can easily unplug the device from the mains if a fault occurs.

The mains adapter is intended exclusively for use in buildings. Only use the mains adapter in dry places and do not expose it to moisture of any sort.

Even when you are not using the mains adapter store it in a dry place and unplug it from the mains if the piano is not used for a while.

The mains adapter is maintenance-free and may only be repaired by qualified person. Never try to open it!

Only use the mains adapter supplied for the piano and never use it for other devices.

Only mains adapters recommended by the manufacturer may be used for the piano.

Please always contact the customer service department in the event of problems.

Using non-certified mains adapters will invalidate the warranty.

Specifications

Name	Feature
Measurements W x D x H	· 4 ft 9.7"/1' and 7.9"/3' and 5.7'
Weight	· 169.8 pounds
Power input Operation	· 60 Watt
Keyboards	· 88 keys, weighted, Fatar Grand Touch TP40
Attack dynamic	· 6 levels (light, medium, heavy and constant)
Pedals	· Soft / Sostenuto / Sustain
Polyphony	· Max. 135 Tones
Number of integrated sounds	· 10
Musical output	· 4 x 20 Watt
Speakers	<ul style="list-style-type: none"> · 2 Fullrange-Stereo-Loudspeakers · 2 High frequency twitter speakers
Recording function	· Integrated recorder
Recording format	· Standard MIDI-file (Format 0, SMF)
Connections	<ul style="list-style-type: none"> · MIDI IN -MIDI OUT · Aux In -Aux Out · 2 x Headphone sockets (6,3 mm jack) · USB Type B / to Host
Power	· Main adaptor : 15V/5A