

Roland®



VGA-5

Owner's Manual

Thank you, and congratulations on your choice of the Roland VGA-5 Guitar Amplifier.

Before using this unit, carefully read the sections entitled:

"IMPORTANT SAFETY INSTRUCTIONS" (page 2)

"USING THE UNIT SAFELY" (page 3-4)

"IMPORTANT NOTES" (page 7-8)

These sections provide important information concerning the proper operation of the unit.



Additionally, in order to feel assured that you have gained a good grasp of every feature provided by your new unit, this manual should be read in its entirety. The manual should be saved and kept on hand as a convenient reference.

Conversions Used in This Manual

- Words enclosed in square brackets [] indicate panel buttons or knobs.
(Example)
[MANUAL]: MANUAL button
[BASS]: BASS knob
- (p. **) indicates a reference page.

Copyright © 2000 ROLAND CORPORATION

All rights reserved. No part of this publication may be reproduced in any form without the written permission of ROLAND CORPORATION.

	CAUTION RISK OF ELECTRIC SHOCK DO NOT OPEN	
ATTENTION: RISQUE DE CHOC ELECTRIQUE NE PAS OUVRIR		
CAUTION: TO REDUCE THE RISK OF ELECTRIC SHOCK, DO NOT REMOVE COVER (OR BACK). NO USER-SERVICEABLE PARTS INSIDE. REFER SERVICING TO QUALIFIED SERVICE PERSONNEL.		



The lightning flash with arrowhead symbol, within an equilateral triangle, is intended to alert the user to the presence of uninsulated "dangerous voltage" within the product's enclosure that may be of sufficient magnitude to constitute a risk of electric shock to persons.



The exclamation point within an equilateral triangle is intended to alert the user to the presence of important operating and maintenance (servicing) instructions in the literature accompanying the product.

INSTRUCTIONS PERTAINING TO A RISK OF FIRE, ELECTRIC SHOCK, OR INJURY TO PERSONS.

IMPORTANT SAFETY INSTRUCTIONS SAVE THESE INSTRUCTIONS

WARNING - When using electric products, basic precautions should always be followed, including the following:

1. Read these instructions.
2. Keep these instructions.
3. Heed all warnings.
4. Follow all instructions.
5. Do not use this apparatus near water.
6. Clean only with a damp cloth.
7. Do not block any of the ventilation openings. Install in accordance with the manufacturers instructions.
8. Do not install near any heat sources such as radiators, heat registers, stoves, or other apparatus (including amplifiers) that produce heat.
9. Do not defeat the safety purpose of the polarized or grounding-type plug. A polarized plug has two blades with one wider than the other. A grounding-type plug has two blades and a third grounding prong. The wide blade or the third prong are provided for your safety. When the provided plug does not fit into your outlet, consult an electrician for replacement of the obsolete outlet.
10. Protect the power cord from being walked on or pinched particularly at plugs, convenience receptacles, and the point where they exit from the apparatus.
11. Only use attachments/accessories specified by the manufacturer.
12. Never use with a cart, stand, tripod, bracket, or table except as specified by the manufacturer, or sold with the apparatus. When a cart is used, use caution when moving the cart/apparatus combination to avoid injury from tip-over. 
13. Unplug this apparatus during lightning storms or when unused for long periods of time.
14. Refer all servicing to qualified service personnel. Servicing is required when the apparatus has been damaged in any way, such as power-supply cord or plug is damaged, liquid has been spilled or objects have fallen into the apparatus, the apparatus has been exposed to rain or moisture, does not operate normally, or has been dropped.

For the U.K.

WARNING: THIS APPARATUS MUST BE EARTHED

IMPORTANT: THE WIRES IN THIS MAINS LEAD ARE COLOURED IN ACCORDANCE WITH THE FOLLOWING CODE.
GREEN-AND-YELLOW: EARTH, BLUE: NEUTRAL, BROWN: LIVE

As the colours of the wires in the mains lead of this apparatus may not correspond with the coloured markings identifying the terminals in your plug, proceed as follows:

The wire which is coloured GREEN-AND-YELLOW must be connected to the terminal in the plug which is marked by the letter E or by the safety earth symbol  or coloured GREEN or GREEN-AND-YELLOW.

The wire which is coloured BLUE must be connected to the terminal which is marked with the letter N or coloured BLACK.

The wire which is coloured BROWN must be connected to the terminal which is marked with the letter L or coloured RED.

USING THE UNIT SAFELY

INSTRUCTIONS FOR THE PREVENTION OF FIRE, ELECTRIC SHOCK, OR INJURY TO PERSONS

About ⚠ WARNING and ⚠ CAUTION Notices

⚠ WARNING	Used for instructions intended to alert the user to the risk of death or severe injury should the unit be used improperly.
⚠ CAUTION	Used for instructions intended to alert the user to the risk of injury or material damage should the unit be used improperly. * Material damage refers to damage or other adverse effects caused with respect to the home and all its furnishings, as well to domestic animals or pets.

About the Symbols

	The ⚠ symbol alerts the user to important instructions or warnings. The specific meaning of the symbol is determined by the design contained within the triangle. In the case of the symbol at left, it is used for general cautions, warnings, or alerts to danger.
	The ⚡ symbol alerts the user to items that must never be carried out (are forbidden). The specific thing that must not be done is indicated by the design contained within the circle. In the case of the symbol at left, it means that the unit must never be disassembled.
	The ● symbol alerts the user to things that must be carried out. The specific thing that must be done is indicated by the design contained within the circle. In the case of the symbol at left, it means that the power-cord plug must be unplugged from the outlet.

ALWAYS OBSERVE THE FOLLOWING



⚠ WARNING

- Before using this unit, make sure to read the instructions below, and the Owner's Manual.
- Do not open or perform any internal modifications on the unit.
- Do not attempt to repair the unit, or replace parts within it (except when this manual provides specific instructions directing you to do so). Refer all servicing to your retailer, the nearest Roland Service Center, or an authorized Roland distributor, as listed on the "Information" page.
- Never use or store the unit in places that are:
 - Subject to temperature extremes (e.g., direct sunlight in an enclosed vehicle, near a heating duct, on top of heat-generating equipment); or are
 - Damp (e.g., baths, washrooms, on wet floors); or are
 - Humid; or are
 - Exposed to rain; or are
 - Dusty; or are
 - Subject to high levels of vibration.
- Make sure you always have the unit placed so it is level and sure to remain stable. Never place it on stands that could wobble, or on inclined surfaces.
- The unit should be connected to a power supply only of the type described in the operating instructions, or as marked on the unit.









⚠ WARNING

- Do not excessively twist or bend the power cord, nor place heavy objects on it. Doing so can damage the cord, producing severed elements and short circuits. Damaged cords are fire and shock hazards!
- This unit, either alone or in combination with an amplifier and headphones or speakers, may be capable of producing sound levels that could cause permanent hearing loss. Do not operate for a long period of time at a high volume level, or at a level that is uncomfortable. If you experience any hearing loss or ringing in the ears, you should immediately stop using the unit, and consult an audiologist.
- Do not allow any objects (e.g., flammable material, coins, pins); or liquids of any kind (water, soft drinks, etc.) to penetrate the unit.
- In households with small children, an adult should provide supervision until the child is capable of following all the rules essential for the safe operation of the unit.
- Protect the unit from strong impact. (Do not drop it!)

⚠ WARNING

- Do not force the unit's power-supply cord to share an outlet with an unreasonable number of other devices. Be especially careful when using extension cords—the total power used by all devices you have connected to the extension cord's outlet must never exceed the power rating (watts/amperes) for the extension cord. Excessive loads can cause the insulation on the cord to heat up and eventually melt through. 
- Before using the unit in a foreign country, consult with your retailer, the nearest Roland Service Center, or an authorized Roland distributor, as listed on the "Information" page. 

⚠ CAUTION

- The unit should be located so that its location or position does not interfere with its proper ventilation. 
- Always grasp only the plug on the power-supply cord when plugging into, or unplugging from an outlet. 
- Try to prevent cords and cables from becoming entangled. Also, all cords and cables should be placed so they are out of the reach of children. 
- If the unit could become a hazard if it moves, all caster wheels should be removed once the unit has been placed at the place of installation, or has been loaded onto a vehicle. 
- Never climb on top of, nor place heavy objects on the unit. 
- Never handle the power cord or its plug with wet hands when plugging into, or unplugging from, an outlet. 
- Before moving the unit, disconnect the power plug from the outlet, and pull out all cords from external devices. 
- Before cleaning the unit, turn off the power and unplug the power cord from the outlet. 
- Whenever you suspect the possibility of lightning in your area, pull the plug on the power cord out of the outlet. 



Contents

IMPORTANT SAFETY INSTRUCTIONS	2
USING THE UNIT SAFELY.....	3
IMPORTANT NOTES	7
Attaching and Removing the Casters	8
Main Features.....	9
Basic Operation	12
Using the VGA-5 Like Conventional Amplifiers	12
Basic Operation of the Front Panel Controls.....	12
How to Select the Delay, Chorus, and Reverb Variations	13
Noise Suppressor	13
Basic Operation of the Rear Panel Controls	14
How to Make the Connections.....	15
Turning the Power On and Off.....	15
Part Names and Functions	16
COSM AMPLIFIER.....	16
EFFECTS.....	17
EFX.....	17
DELAY	18
CHORUS.....	19
REVERB.....	20
Rear Panel.....	20
FOOT CONTROL	21
About the Memory Function	23
Calling Up Memory.....	23
Changing the Memory Settings (Edit).....	23
Storing Knob and Button Settings to Memory (Write).....	23
Using the GFC-50 to Operate the VGA-5	24
Connecting the VGA-5 and the GFC-50	24
Switching Memories With the GFC-50.....	24
How to Call Up the VGA-5's Memories Using the GFC-50	24
Storing to the VGA-5's Memories Using the GFC-50.....	25
Control Using an External Foot Switch or Pedal	25
Pedal Hold Function and MIDI Settings.....	26
Pedal Hold On/Off Setting	26
Omni Mode On/Off Setting.....	26
Volume/Wah Control Number Setting	27
Regarding Other Control Number Correspondences	27

Appendices28

- Restoring the Factory Settings28
- Calling Up the Factory Tone Settings for Each Individual Bank.....29
- Problems With the Sound.....29
- Block Diagram/Effect Connection Procedure.....31
- Memory Sheet (Factory tone settings).....32
- MIDI Implementation Chart33
- Specifications34

IMPORTANT NOTES

In addition to the items listed under “IMPORTANT SAFETY INSTRUCTIONS” and “USING THE UNIT SAFELY” on pages p. 2 and p. 3, please read and observe the following:

Power Supply

- Do not use this unit on the same power circuit with any device that will generate line noise (such as an electric motor or variable lighting system).
- Before connecting this unit to other devices, turn off the power to all units. This will help prevent malfunctions and/or damage to speakers or other devices.

Placement

- Using the unit near power amplifiers (or other equipment containing large power transformers) may induce hum. To alleviate the problem, change the orientation of this unit; or move it farther away from the source of interference.
- This device may interfere with radio and television reception. Do not use this device in the vicinity of such receivers.
- Do not expose the unit to direct sunlight, place it near devices that radiate heat, leave it inside an enclosed vehicle, or otherwise subject it to temperature extremes. Excessive heat can deform or discolor the unit.
- To avoid possible breakdown, do not use the unit in a wet area, such as an area exposed to rain or other moisture.
- Do not allow rubber, vinyl, or similar materials to remain on this unit for long periods of time. Such objects can discolor or otherwise harmfully affect the finish.
- Do not put anything that contains water (e.g., flower vases) on this unit. Also, avoid the use of insecticides, perfumes, alcohol, nail polish, spray cans, etc., near the unit. Swiftly wipe away any liquid that spills on the unit using a dry, soft cloth.
- During operation, this device must be placed at a distance of no less than 50 cm from any walls.
- Do not allow objects to remain on top of the unit while it is in operation.
 - If you cover the heat-dissipation fins, their function is defeated, and their temperature can rise to overly high levels, which could cause burns if they are accidentally touched.
 - Placing heavy objects on this unit may result in injury if it overturns or falls.

Maintenance

- For everyday cleaning wipe the unit with a soft, dry cloth or one that has been slightly dampened with water. To remove stubborn dirt, use a cloth impregnated with a mild, non-abrasive detergent. Afterwards, be sure to wipe the unit thoroughly with a soft, dry cloth.
- Never use benzine, thinners, alcohol or solvents of any kind, to avoid the possibility of discoloration and/or deformation.

Repairs and Data

- Please be aware that all data contained in the unit's memory may be lost when the unit is sent for repairs. Important data should always be written down on paper (when possible). During repairs, due care is taken to avoid the loss of data. However, in certain cases (such as when circuitry related to memory itself is out of order), we regret that it may not be possible to restore the data, and Roland assumes no liability concerning such loss of data.

Memory Backup

- This unit contains a battery which powers the unit's memory circuits while the main power is off. To avoid the unexpected loss of data in memory, have this battery replaced with a new one every 5 years. Please be aware that the actual life of the battery can vary depending on how the unit is used. When it is time to change the battery, consult with your retailer, the nearest Roland Service Center, or an authorized Roland distributor, as listed on the “Information” page.

Additional Precautions

- Unfortunately, it may be impossible to restore the contents of data that was stored in the unit's memory once it has been lost. Roland Corporation assumes no liability concerning such loss of data.
- Use a reasonable amount of care when using the unit's buttons, sliders, or other controls; and when using its jacks and connectors. Rough handling can lead to malfunctions.
- When connecting / disconnecting all cables, grasp the connector itself—never pull on the cable. This way you will avoid causing shorts, or damage to the cable's internal elements.
- A small amount of heat will radiate from the unit during normal operation.

IMPORTANT NOTES

- To avoid disturbing your neighbors, try to keep the unit's volume at reasonable levels. You may prefer to use headphones, so you do not need to be concerned about those around you (especially when it is late at night).
- When you need to transport the unit, package it in the box (including padding) that it came in, if possible. Otherwise, you will need to use equivalent packaging materials.
- Use only the specified expression pedal (EV-5; optional). By connecting any other expression pedals, you risk causing malfunction and/or damage to the unit.
- Use a cable from Roland to make the connection. If using some other make of connection cable, please note the following precautions.
 - Some connection cables contain resistors. Do not use cables that incorporate resistors for connecting to this unit. The use of such cables can cause the sound level to be extremely low, or impossible to hear. For information on cable specifications, contact the manufacturer of the cable.
- To avoid injury, avoid placing hands at points indicated by the arrows in the following figure.

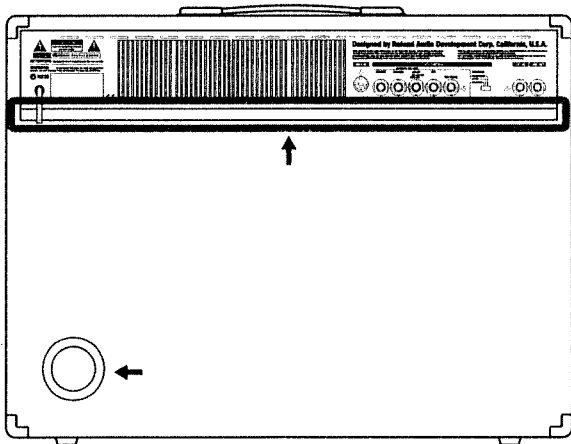

- When this device is in operation, the cooling fins located on the rear panel will become hot. Take care not to touch them with your hands.

Attaching and Removing the Casters

Attaching all of the casters can make it easier to move the amplifier.

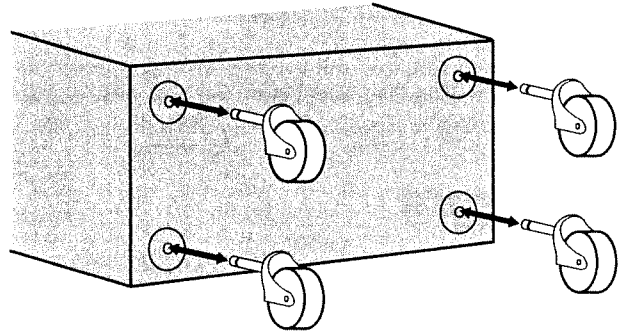

When using casters, take care not to allow fingers or other parts of the hand or body to get pinched or injured.



Be sure to remove all casters when accidental movement may be dangerous such as when setting up the VGA-5 on stage or when transporting it in a vehicle.



If casters have been attached to the amp, make sure it is used only on a stable, level surface.

Main Features

The **VGA-5**, a 65 watt guitar amplifier with built-in memory functions, comprises two sections: a **COSM amplifier section** featuring eleven COSM amplifier types along with ten different COSM speaker types, that you can freely combine to create sounds; and an effects section with four kinds of effects, which can be used simultaneously.

The cabinet's 12 inch (30 cm) built-in bass reflex speaker provides rich sound over an extended range, from powerful lows to a crisp high end.

COSM Amplifiers

- The VGA-5 features eleven guitar amplifier sounds, including not only familiar solid-state and tube amplifier sounds, but also an acoustic amplifier sound that allows you to perform with the sound of an acoustic guitar.
- Gain, volume, three-band equalizer, and presence controls give you even more precise control over the sound creation process. All of these functions are set so they suit the unique characteristics of each amplifier type.
- Built-in speaker modeling also takes into account cabinet properties. While naturally reproducing the original sound of legendary equipment, it is also possible to create new sounds by changing the speaker configurations.

Effects

- The VGA-5 features four built-in effects: EFX, delay, chorus, and reverb. All of them can be used at the same time. You can use the foot switch to turn each effect on and off.
- The EFX includes six effects, wah, tremolo, compressor, slow gear, phaser, and flanger; you can select any one of these to use at a time.
- The delay time can be input by tapping a button. This makes setting the delay time simple. Delay also has a Hold function that allows you to repeatedly play back a recorded phrase.

COSM (Composite Object Sound Modeling)

Technology that uses advanced methods to create a virtual reconstruction of actual physical objects, based on aspects such as their structure and constituent elements, is referred to as "modeling technology." COSM represents proprietary technology from Roland, which combines a number of sound modeling technologies, and takes them to a new level of sound creation.

Memory Function

You can store groups of settings in the VGA-5's memory, for example for amplifier type, speaker type, and effect settings. Switching the memory then allows you to instantly select just the right settings for what you are playing.

Simple Operation

The VGA-5 provides simple button and knob controls, which let you do everything from switching memory to creating sounds, quickly and easily.

Superb Expandability

- The VGA-5 is equipped with an external input jack which allows connection of guitar synthesizers and other devices. There is also a line out jack, convenient for recording.
- The VGA-5 is also equipped with foot switch jacks. These let you use your foot to switch memory and turn effects on and off. You can also connect an expression pedal to control volume and wah.
- A MIDI IN connector is also provided. You can control the VGA-5 with an external MIDI device, using MIDI messages to switch memory and perform other functions.

Main Features

List of Amplifier Types

Thanks to Roland's proprietary Composite Object Sound Modeling (COSM) technology, the VGA-5 is able to faithfully reproduce the sounds and nuances of 11 distinct amplifier types—from classic combos to modern high-gain stacks. Not only do these amplifier models *sound* like the originals, but they *feel* like the originals, giving you authentic control and unrivaled response.

ACOUSTIC

By combining acoustic guitar simulation with COSM amplifier modeling technology, this original amplifier model gives you a dynamic acoustic guitar sound using a standard electric guitar. The resulting tone varies according to the characteristics of the electric guitar's pickups, so be sure to try out various pickup positions.

JC CLEAN

This is a model of Roland's famous JC-120 Jazz Chorus guitar amplifier, a legendary "clean" amplifier that's been used on thousands of recordings and on stages the world over—from jazz to rock, ska, funk, reggae and more. The ultra-clean, ultra-flat sound offers a smooth, musical high end—perfect for use with onboard and external effects.

AMERICAN CLEAN

This is modeled on the classic Fender Twin Reverb amplifier, used in a wide variety of musical styles, from country to blues, jazz and rock. Exhibiting rich lows and a bright high end, Fender Twins are also known for their "crunch" tone when the gain is boosted, and no sound at all when their tone controls are set to zero. Both of these characteristics are faithfully reproduced in the VGA-5. Because the Twin amplifier's overdriven sound is closely linked to its EQ controls, adjusting EQ will change the nature of your "crunch" sound.

CLASSIC STACK I

This is modeled on the sound and response of Input I on a Marshall JMP1987 amplifier (see below).

CLASSIC STACK I+II

This is modeled on the sound and response of a Marshall JMP1987 amplifier with Inputs I and II connected in parallel.

With a 50-watt head amplifier using two EL34 tubes and a cabinet housing four 12-inch vintage greenback speakers, the legendary JMP1987 is renowned for its smooth tone and presence—perfect for classic and hard rock. At full volume with its EQ controls cranked, the JMP1987 offers the compression and sustain of a fully driven power amplifier. The warm, overdriven tones of this model respond exceptionally well to volume, tonal and dynamic nuances on the guitar.

MODERN STACK 1

This is modeled on the Soldano SLO-100, a modern tube amplifier featuring a high-gain preamplifier. Since plenty of distortion is provided at the preamplifier stage, and equalization is placed after the preamplifier, this is an effective choice for distorted sounds.

MODERN STACK 2

This is modeled on the Peavey EVH-5150. The high-gain preamplifier uses three 12AX7s, so even at low volumes with the Master volume cut back, you can still get heavy distortion and sustain. EQ is placed after the preamplifier, which is good for shaping preamplifier distortion sounds. Use this model with a humbucking pickup for an American hard rock sound.

METAL STACK

This is an original super high-gain metal amplifier. It features heavy distortion, unbelievable lows and incredible sustain, even when using single-coil pickups. The Metal Stack model is great for a variety of tones, including leads, harmonics, and rhythm sounds for thrash metal, grunge, and more.

TWEED

This is modeled on the vintage Fender Bassman 4x10 combo. The amplifier's four 10-inch speakers produce a clear upper-midrange with a fat low end, and its unique crunch tones make it a favorite of blues-rock guitarists. The tube-based rectifier circuit of the Bassman gives the amplifier a very dynamic response, letting you easily control its overdrive and tonal nuances with your playing.

MODERN COMBO

This is modeled on the Matchless D/C-30, a modern tube combo amplifier used widely in different genres, from blues and rock to fusion. This amplifier responds exceptionally well to dynamic playing, and with the Master Volume turned up, you'll get the crunch and "feel" of a fully driven power amplifier.

BRITISH COMBO

This is modeled on the Vox AC-30TB, the rock amplifier that created the Liverpool sound of the '60s. It can produce a broad range of sounds, from clean to overdrive, with increased distortion and greater power in the low-midrange when the amplifier's gain is boosted. In addition, the treble EQ can change the sound over a wide range of frequencies, cutting the midrange when the treble is turned up, while creating a full, rich midrange when the treble is turned down.

The trademarks listed in this document are trademarks of their respective owners, which are separate companies from Roland. Those companies are not affiliated with Roland and have not licensed or authorized Roland's VGA-5. Their marks are used solely to identify the equipment whose sound is simulated by Roland's VGA-5.

List of Speaker Types

ORIGINAL:

Original speakers provided with the selected amplifier type.

CLASSIC 1-12":

Open-backed cabinet using one 12-inch classic-type speaker (*1).

CLASSIC 2-12":

Open-backed cabinet using two 12-inch classic-type speakers.

CLASSIC 4-10":

Open-backed cabinet using four 10-inch classic-type speakers.

CLASSIC 4-12":

Large sealed enclosure containing four 12-inch classic-type speakers.

CLASSIC 8-12":

Dual large sealed enclosures each containing four 12-inch classic-type speakers.

MODERN 1-12":

Open-backed cabinet using one 12-inch modern-type speaker (*2).

MODERN 2-12":

Open-backed cabinet using two 12-inch modern-type speakers.

MODERN 4-10":

Open-backed cabinet using four 10-inch modern-type speakers.

MODERN 4-12":

Large sealed enclosure containing four 12-inch modern-type speakers.

MODERN 8-12":

Dual large sealed enclosures each containing four 12-inch modern-type speakers.

(*1) Classic-type speaker unit with a smooth upper-midrange and comparatively low power handling capabilities.

(*2) Modern-type speaker unit with a powerful upper-midrange and comparatively greater power input handling.

Basic Operation

Using the VGA-5 Like Conventional Amplifiers

Press **[MANUAL]**, lighting the indicator, when you want to operate the VGA-5 as you would a regular analog amplifier, whereby you make new settings with the knobs, and sound is produced in accord with the positions of the knobs on the front panel.

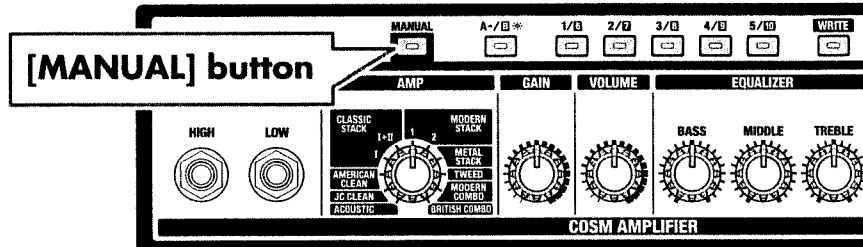

Basic Operation of the Front Panel Controls

Memory Buttons

Used for calling up memories and storing settings.

When **[A/B]** is not lighted, the memories numbered from 1 through 5 can be selected (in the illustration, Memory 1 is selected).

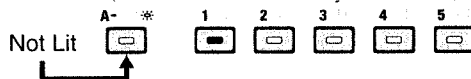

When **[A/B]** is lit, the memories numbered from 6 through 10 can be selected (in the illustration, Memory 6 is selected).

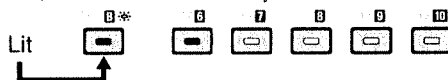

* Memories contain the factory-set knob settings.

POWER Switch

MASTER Knob

Adjusts the VGA-5's volume level or the volume of the headphones.
* The MASTER knob settings are not stored.

WRITE Button

Press this when storing knob or button settings to memory. For more detailed information, refer to "About the Memory Function" (p. 23).

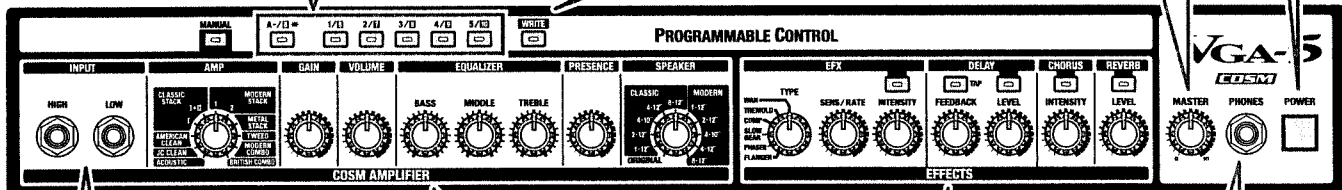

Knob and Button Settings That Can Be Stored

INPUT Jacks (HIGH/LOW)

Connect the guitar to HIGH or LOW according to the guitar's output level. Normally, the guitar will be connected to HIGH. If using a guitar with especially high output, connect to LOW.

COSM AMPLIFIER

You can use these controls to create sounds with combinations of amplifier types (eleven types) and speaker types (eleven types, including ORIGINAL).

Headphone Jack [PHONES]

Used for connecting headphones.
* Sound is not output from the VGA-5's speakers when headphones are connected.

EFFECTS

Each of the delay, chorus, and reverb effects features variations (*1).

Variation List

- | | | | |
|----------------|------------|---------|-----------|
| DELAY: | 1. NORMAL | 2. WARM | 3. HOLD |
| CHORUS: | 1. NATURAL | 2. WARM | 3. BRIGHT |
| REVERB: | 1. PLATE | 2. ROOM | 3. HALL |

(*1) Refer to "How to Select the Delay, Chorus, and Reverb Variations."

How to Select the Delay, Chorus, and Reverb Variations

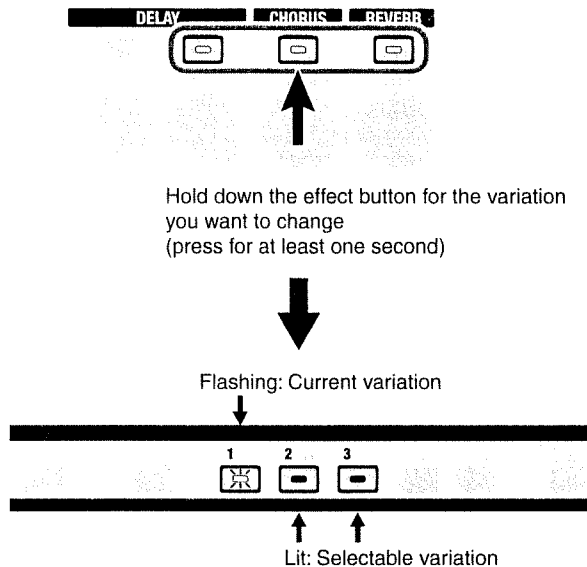

- * Memory buttons 1, 2, and 3 correspond to Variations 1, 2, and 3.
- * For more details on each variation, refer to Delay (p. 18), Chorus (p. 19), and Reverb (p. 20).

1. Hold down, for at least one second, the effect button (either **[DELAY]**, **[CHORUS]**, or **[REVERB]**) for the variation you want to change.
The pressed button flashes, and at the same time the indicators for the **[1/6]**, **[2/7]**, and **[3/8]** buttons light up to indicate the variation number.
2. Press the **[1/6]**, **[2/7]**, or **[3/8]** button to select the variation.
The pressed button flashes.
3. Press the effect button pressed in Step 1 one more time to complete the setting.

Noise Suppressor

The VGA-5 features a built-in noise suppressor. The noise suppressor is an effect that reduces noise that is picked up by guitar pickups. The noise suppressor effect can be set to any of ten levels.

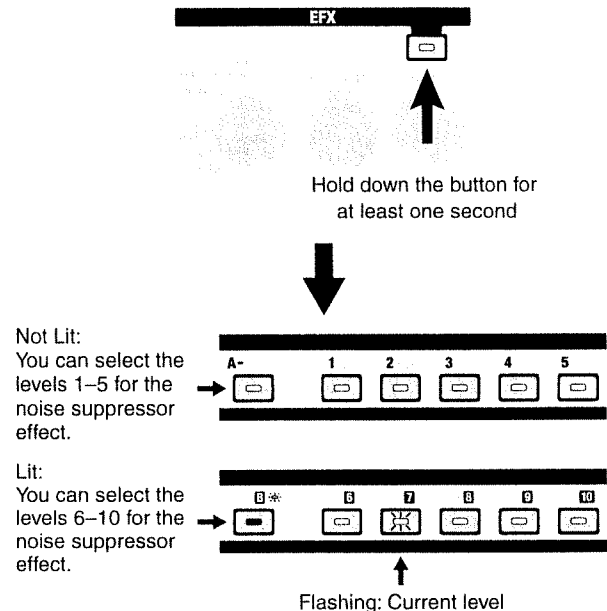

Not Lit:
You can select the levels 1–5 for the noise suppressor effect.

Lit:
You can select the levels 6–10 for the noise suppressor effect.

- * When set to “1,” the noise suppressor effect is minimal; a setting of “10” provides heavy suppression.
1. Hold down the **[EFX]** button for at least one second.
The **[EFX]** flashes, and at the same time the indicators for the **[1/6]**–**[5/10]** buttons light up. The flashing button indicator shows the current noise suppressor level.
 2. Press the **[A/B]** or one of the button **[1/6]**–**[5/10]**, to adjust the noise to a suitable level.
 3. Press **[EFX]** one more time to complete the setting.
 - * Setting the noise suppressor to “10” (effect depth) may result in the sound being cut off fast when the guitar volume is low.
 - * The noise suppressor setting is applied to both Manual mode and Memory mode.
 - * Settings cannot be made individually for each memory.
 - * This setting is stored by the VGA-5, even without the **WRITE** button being pressed.

Basic Operation of the Rear Panel Controls

FOOT CONTROL
 You can use these in turning effects on and off and for switching memories.
 You can also connect an expression pedal to control volume and wah.

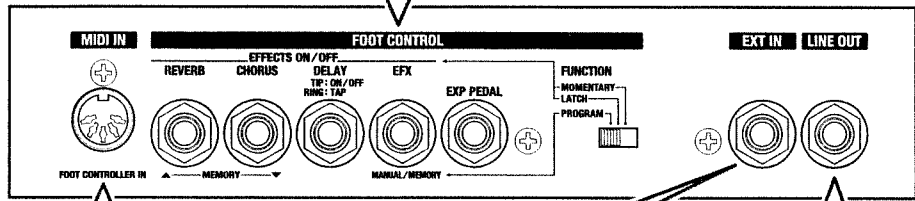

MIDI IN Conector
 With a foot controller connected, you can use your foot to switch memories.

EXT Input Jack (EXT IN)
 This lets you input sounds from other devices.

LINE OUT Jack
 This outputs the COSM amp and effect sound to external devices.

You can also turn effects on and off, and switch memories by connecting a BOSS FS-5U foot switch (optional) to the FOOT CONTROL jacks.

When using the switch to turn effects on and off:

Set the FUNCTION switch to "MOMENTARY."
 This enables the effects to be turned on and off with a FS-5U (optional).

When using the switch to switch memories:

Set the FUNCTION switch to "PROGRAM."
 This enables switching of memories and switching between Manual and Memory modes with the FS-5U (optional).

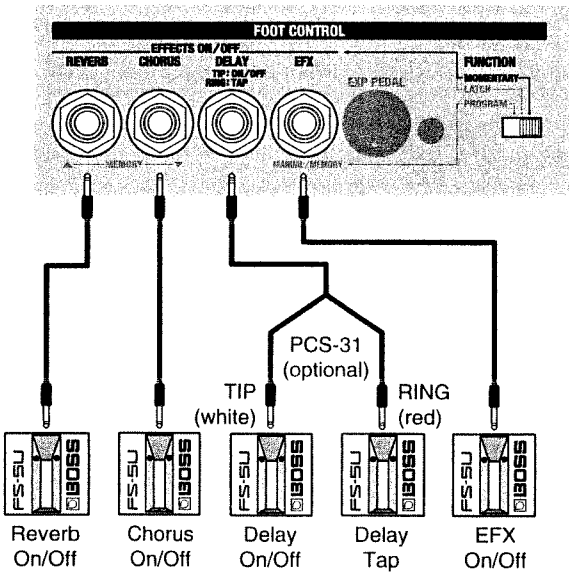

When using the BOSS FS-5L latch-type switch (optional), the foot switch takes priority, regardless of the effect on/off settings in memory. For example, if the foot switch is on, then the effect is turned on. Use with the FUNCTION switch set to "LATCH."

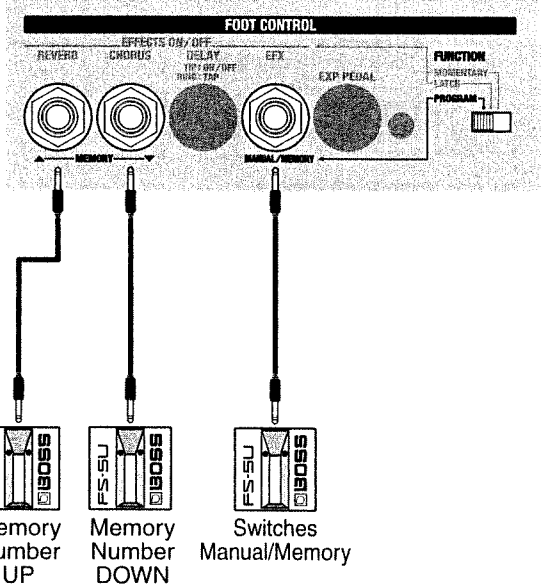

* The DELAY jack does not function for switching memories

* Even if the FUNCTION switch is set to "LATCH," use the FS-5U (optional) for the delay tap.

How to Make the Connections

Referring to the figure below, connect the VGA-5 and other devices as shown.

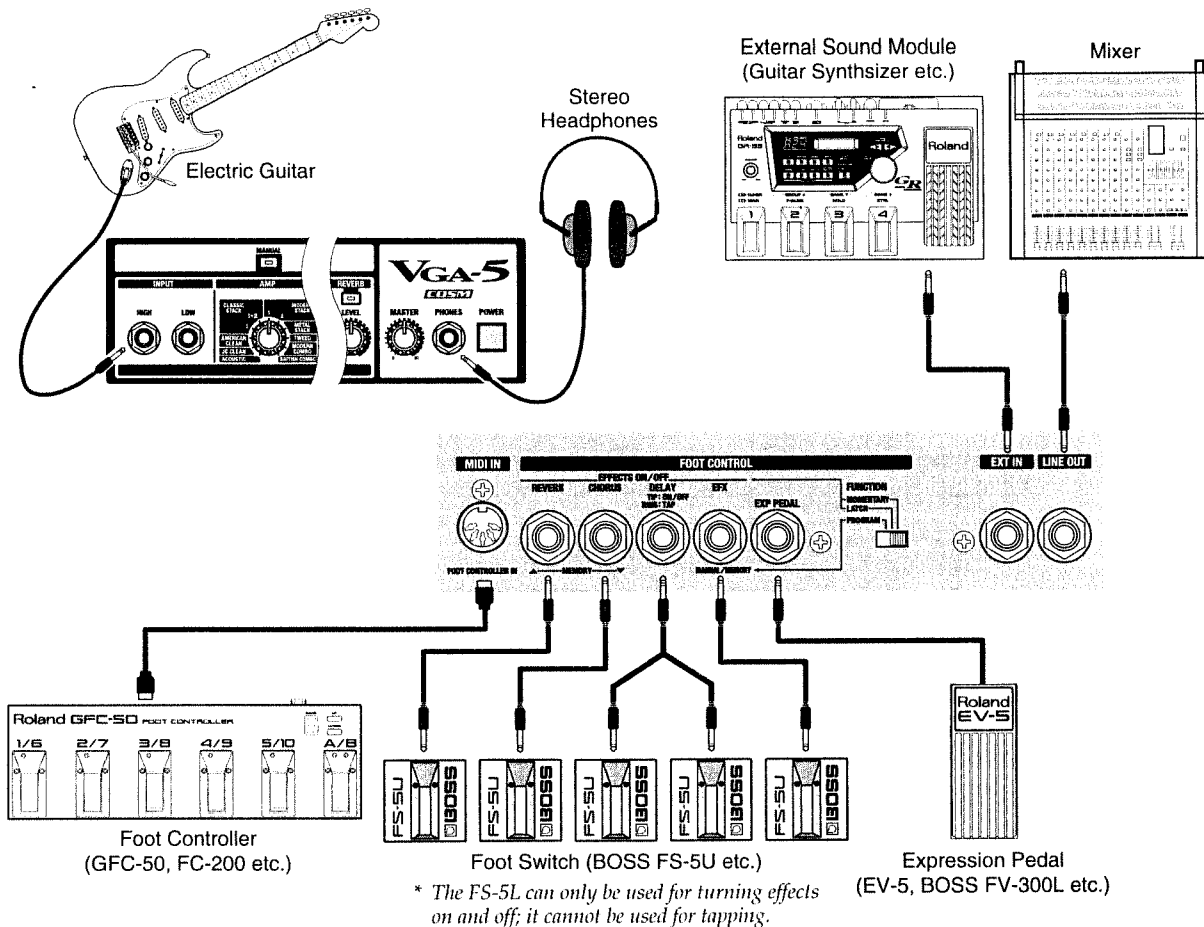

The following equipment will add additional functionality to your VGA-5 system.

- Foot Controller (optional: Roland GFC-50, FC-200)
- Expression Pedal (optional: Roland EV-5, BOSS FV-300L)
- Foot Switch (optional: BOSS FS-5U/FS-5L)

* The FS-5L can only be used for some functions (p. 22).

- * Use only the specified expression pedal (Roland EV-5, BOSS FV-300L; optional). By connecting any other expression pedals, you risk causing malfunction and/or damage to the unit.
- * When switching memories or using the delay tap, use the FS-5U (momentary type).
- * To prevent malfunction and/or damage to speakers or other devices, always turn down the volume, and turn off the power on all devices before making any connections.
- * Always be sure to turn **[MASTER]** down to "0" whenever connecting or disconnecting headphones.

Turning the Power On and Off

Once the connections have been completed, turn on power to your various devices in the order specified. By turning on devices in the wrong order, you risk causing malfunction and/or damage to speakers and other devices.

Device connected to EXT IN → VGA-5 → Device connected to LINE OUT

* When the power is turned on, sound will be produced using the same settings in effect when the power was last turned off.

- * When this device is in operation, the cooling fins located on the rear panel will become hot. Take care not to touch them with your hands.
- * This unit is equipped with a protection circuit. A brief interval (a few seconds) after power up is required before the unit will operate normally.
- * Always make sure to have the volume level turned down before switching on power. Even with the volume all the way down, you may still hear some sound when the power is switched on, but this is normal, and does not indicate a malfunction.

Part Names and Functions

COSM AMPLIFIER

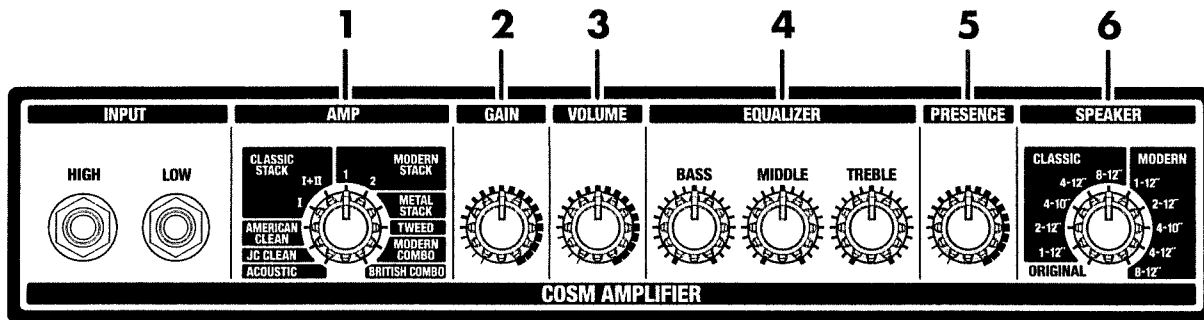

When you want to have sound produced in accord with the positions of the panel knobs, press **[MANUAL]**, lighting the indicator.

1 Amplifier Type Switch [AMP]

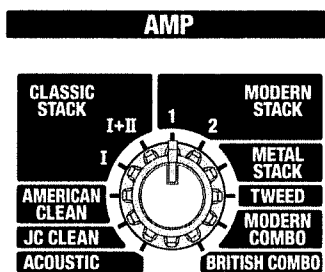

Lets you select from eleven types of amplifiers.



Description (p. 10)

* The amp type switch may not function properly if not clicked into a notched position.

2 Gain Knob [GAIN]

Adjusts the gain (intensity or amount of distortion) for the selected amplifier.

3 Volume Knob [VOLUME]

Adjusts the volume. Using the volume knob is convenient for adjusting the volume levels between memories.

4 Equalizer (EQUALIZER)

Three-band equalizer. Works in different ways depending on the selected amplifier.

Bass Knob [BASS]

Adjusts the sound of the low-frequency range.

Middle Knob [MIDDLE]

Adjusts the sound of the midrange frequencies.

Treble Knob [TREBLE]

Adjusts the sound of the high-frequency range.

* COSM faithfully models the special features and characteristics of a variety of amplifiers; with certain amplifiers, no sound may be produced when **[BASS]**, **[MIDDLE]**, and **[TREBLE]** are all set to 0.

5 Presence Knob [PRESENCE]

Adjusts the presence of the sound.

6 Speaker Type Switch [SPEAKER]

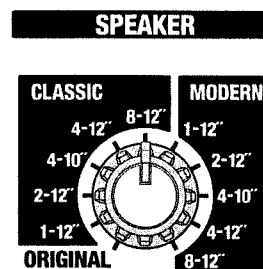

Lets you select from eleven speaker types (including ORIGINAL) featuring different numbers of speakers, speaker sizes, and cabinets.

ORIGINAL refers to the speakers originally furnished in the amp selected with the amp type switch.



Description (p. 11)

* The speaker type switch may not function properly if not clicked into a notched position.

EFFECTS

The four types of effect, EFX, delay, chorus, and reverb, can be used simultaneously.

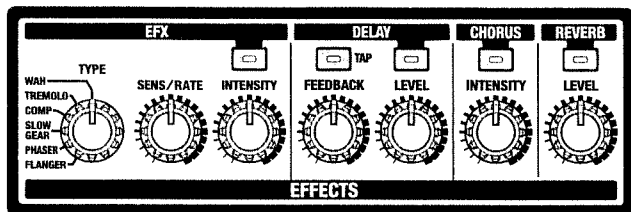

When you want to have sound produced in accord with the positions of the panel knobs, press **[MANUAL]**, lighting the indicator.

EFX

EFX includes six effects, Wah, Tremolo, Compressor, Slow Gear, Phaser, and Flanger; any one of these can be selected at one time.

(1) EFX Button [EFX]

Turns EFX on and off. Indicator is lit when the effect is on.
 * You can also use a foot switch to turn this on and off (p. 21).

(2) Type Switch [TYPE]

Provides for selection from six different EFX effects.
 * The [SENS/RATE] and [INTENSITY] knobs function differently depending on the type selected. (Diagram below)

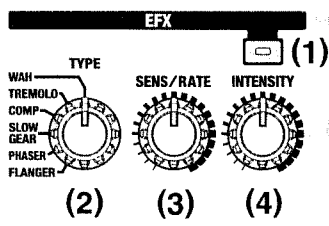

* The type switch may not function properly if not clicked into a notched position.

● WAH

This effect creates a unique tone by changing the frequency response of a filter. By connecting a separately available expression pedal (e.g., Roland EV-5 or BOSS FV-300L; optional) you can control the wah effect in real time.

● TREMOLO

Tremolo is an effect that cyclically modulates the volume.

● COMP (Compressor)

The compressor is an effect that attenuates loud input levels and boosts soft input levels, thus evening out the volume to create sustain without distortion.

● SLOW GEAR

Slow Gear is an effect that fades-in each note (violin-style playing) by detecting the picking of the guitar. It lowers the volume of the attack of the input signal, and gradually raises it.

● PHASER

By adding varied-phase portions to the direct sound, the phaser effect gives a whooshing, swirling character to the sound.

● FLANGER

The flanging effect gives a twisting, jet-airplane-like character to the sound.

(2) TYPE Switch	(3) SENS/RATE Knob	(4) INTENSITY Knob
WAH *	You can adjust the effect with the knob in the same way as moving the wah pedal to a corresponding position. Turning the knob completely to the right (clockwise) is equivalent to pressing the pedal down completely, while turning the knob completely to the left (counterclockwise) is equivalent to bringing the pedal toe back up.	(No knob assignment)
TREMOLO	Adjusts the rate of the volume change.	Adjusts the intensity of the effect.
COMP	Adjusts the strength of the attack when picking. The more the knob is turned to the right, the sharper the sound's attack is; turning the knob to the left creates a crisp sound with good articulation.	Adjusts the range (time) for which low input is expanded and the volume set at a fixed level. The more the knob is turned to the right, the longer the sustain becomes.
SLOW GEAR	Adjusts the Slow Gear sensitivity level. When the knob is turned to the left, the effect is not applied; the effect becomes apparent when the knob is turned to the right.	Adjusts the time it takes to reach maximum volume after picking.
PHASER	Adjusts the undulation rate.	Adjusts the intensity of the undulation.
FLANGER	Adjusts the undulation rate.	Adjusts the intensity of the undulation.

* When the wah effect is on, you cannot control the VCA-5's volume with the expression pedal.

DELAY

Delay Variations

- 1 **NORMAL**
Provides a normal delay effect.
- 2 **WARM**
Produces a warm delay sound with a restrained high end.
- 3 **HOLD**
Allows you to record what is played, and play that back repeatedly.



Instructions on selecting variations (p. 13)

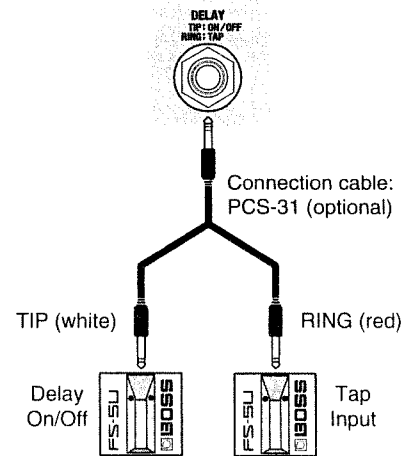
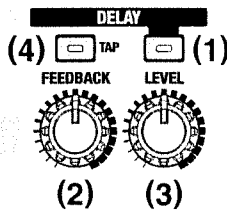

* If only one foot switch is connected, and the (optional) PCS-31 is not used, only the delay can be switched on/off.

(1) Delay Button [DELAY]

Turns the delay on and off. Indicator is lit when the effect is on.

* You can also use a foot switch to turn this on and off (p. 21).

(2) Feedback Knob [FEEDBACK]

Adjusts the amount of delay repeat.

* This is not functional when HOLD is selected as the variation.

(3) Level Knob [LEVEL]

Adjusts the volume of delay sound.

(4) Tap Button [TAP]

When NORMAL or WARM is selected as the delay variation, you can set the delay time in the range of 0–1.8 seconds.

When you press [TAP] twice in time with the tempo of the song being performed, the [TAP] indicator flashes at the tempo at which the button is pressed, and the delay time is set.

* The interval at which the [TAP] indicator flashes shows the approximate tempo.

You can also use a foot switch to input the taps. However, you must use the optional PCS-31 connector cord and connect the foot switch as shown below.

Setting Short Delay Times (0–200 msec)

You can set delay times that are difficult to set with tap input.

1. Hold down [TAP] and press [DELAY].
[TAP] and [DELAY] begin to flash rapidly.
In this state the delay time is 0 msec.
2. Each press of [TAP] lengthens the delay time by one millisecond.
When [TAP] is held down, the setting changes continuously, lengthening the delay time.
If you hold down [TAP], then each press of [DELAY] shortens the delay time by one millisecond.
When [TAP] and [DELAY] is held down, the setting changes continuously, shortening the delay time.
When the setting is made, the [TAP] and [DELAY] indicators flash in sync with the delay time.
3. Press [DELAY] one more time to complete the setting.

About the HOLD Function (Variation 3)

When the delay variation HOLD is selected, you can record what is played, then have that played back repeatedly.

If you connect a momentary-type switch (the BOSS FS-5U: optional), you can then use your foot to control the recording. Connect the foot switch as shown below.

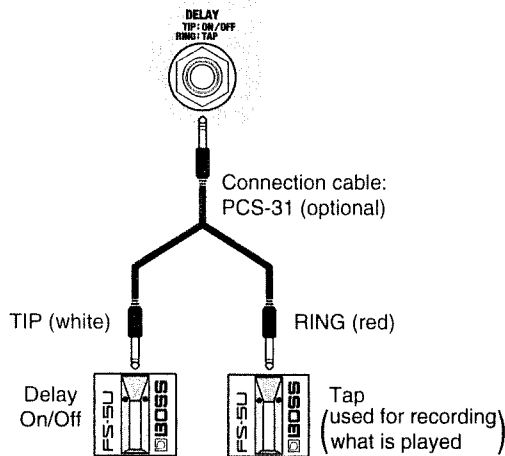

1. Select 3 HOLD as the delay variation (p. 13).
Confirm that the delay has is on.
2. Press the Tap foot switch at the point where you want recording to start.
Recording continues as long as the foot switch is held down.
The [TAP] indicator is lit while the recording is in progress.
Maximum recording time is 1.8 seconds. Recording stops automatically after 1.8 seconds, and the recorded portion is played back repeatedly.
3. When you release the foot switch, recording stops.
The recorded portion is played back repeatedly.
** By carrying out Step 2 while the section is being played back, you can layer the recordings.*
4. Press [DELAY] or the foot switch used for turning on and off the delay to erase the recorded content.
** The [FEEDBACK] knob has no function when HOLD is the delay variation.*
** The HOLD function is not enabled while the delay variation is still being selected (when the DELAY indicator is flashing: p. 13).*

CHORUS

Chorus Variations

- 1 **NATURAL**
Provides a chorus effect featuring natural sense of breadth.
- 2 **WARM**
Produces a chorus effect with depth and body.
- 3 **BRIGHT**
Produces a bright, sparkling chorus effect.



Instructions on selecting variations (p. 13)

** If you want to save changed settings, use the Write operation (p. 23).*

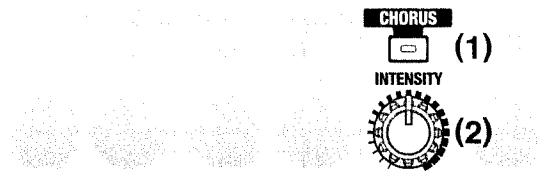

(1) Chorus Button [CHORUS]

Turns the chorus on and off. Indicator is lit when the effect is on.

** You can also use a foot switch to turn this on and off (p. 21).*

(2) Intensity Knob [INTENSITY]

Adjusts the intensity of the chorus.

REVERB

Reverb Variations

- 1 **PLATE**
Simulates a plate reverb (reverb unit that uses the vibrations of a metal plate). Provides a metallic reverberation with an extended high end.
- 2 **ROOM**
Simulates the reverberation typically found inside a room.
- 3 **BRIGHT**
Simulates the reverberation of a concert hall.



Instructions on selecting variations (p. 13)

* If you want to save changed settings, use the Write operation (p. 23).

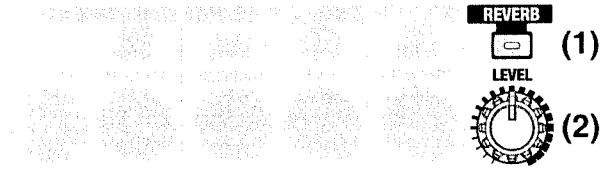

(1) Reverb Button [REVERB]

Turns the reverb on and off. Indicator is lit when the effect is on.

* You can also use a foot switch to turn this on and off (p. 21).

(2) Level Knob [LEVEL]

Adjusts the volume level of the reverb sound.

Rear Panel

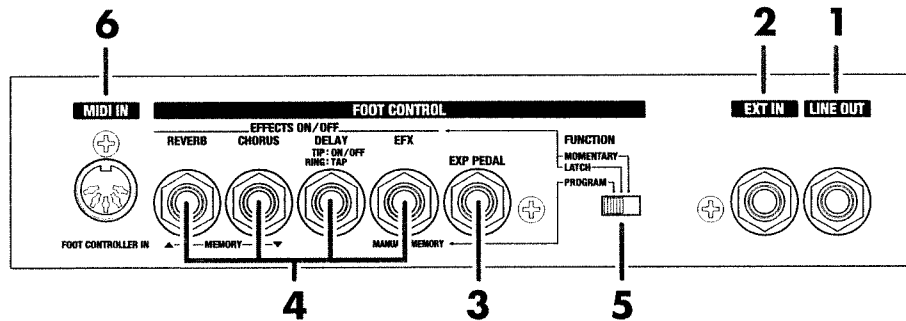

1 Line Out Jack (LINE OUT)

Outputs (in mono) the COSM amplifier and effect sounds. You can connect a mixer or other external device here.

2 External Input Jack (EXT IN)

You can connect (in mono) a guitar synthesizer or other external device here.

The input sound is output from the VGA-5's speaker, headphones, and the LINE OUT jack.

The volume can also be adjusted with the MASTER knob.

FOOT CONTROL

3 Expression Pedal Jack (EXP PEDAL)

Connect an expression pedal (such as the optional Roland EV-5 or BOSS FV-300L) here.

You can use the expression pedal as a volume pedal to adjust the VGA-5's volume level. However, the pedal functions as a wah pedal when EFX type in the effect section is set to wah, and the effect is on.

4 Foot Switch Jack (FOOT SWITCH)

You can connect a foot switch (BOSS FS-5U or FS-5L: optional) and use it to switch memories and to turn effects on and off.

FS-5U Foot Switch

This switch is activated when pressed, and turned off when not pressed. You can use this to switch effects set in the VGA-5's memories on and off and to switch memories.

FS-5L Foot Switch

This foot switch alternately switches the corresponding effect on and off when the pedal is pressed. When the VGA-5's [MANUAL] button is pressed, you can use this foot switch to switch effects on and off just as you would with other conventional amplifiers.

5 Function Switch (FUNCTION)

This switches the function of foot switches connected to the EFX, DELAY, and REVERB jacks between switching the effects on and off, and switching among the memories.

However, the settings cannot be changed for each individual jack.

● Using the Foot Switches to Turn Effects On and Off

**Give priority in determining the effects status (on/off) to the panel controls :
MOMENTARY**

The effects status (on or off) is determined according to the effect status stored in the memories.

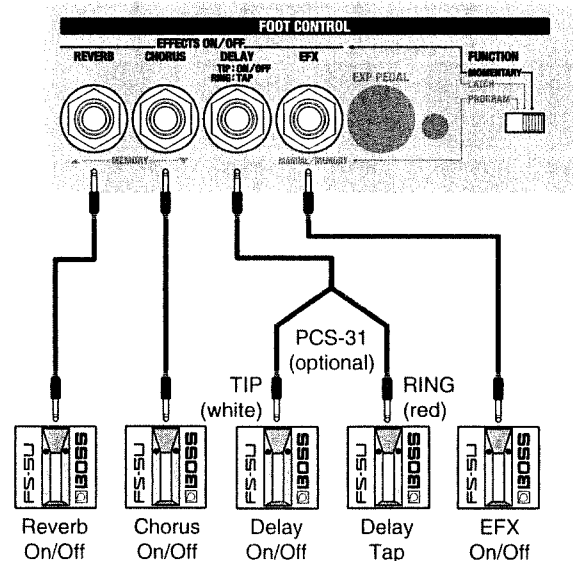

* Connect only BOSS FS-5U foot switches (optional).

* When a single foot switch is connected with one cable to the DELAY jack, the switch is used for switching the delay on and off.

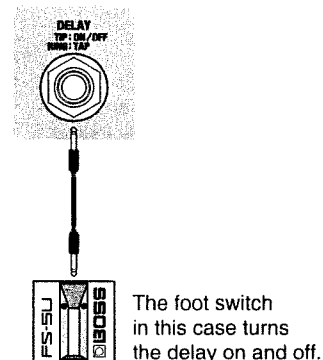

Part Names and Functions

Give priority in determining the effects status (on/off) to the foot switches: LATCH

The foot switches are given priority in determining the current effects status (on or off), regardless of the effect on/off status stored in memory.

The effects now cannot be turned on and off from the VGA-5.

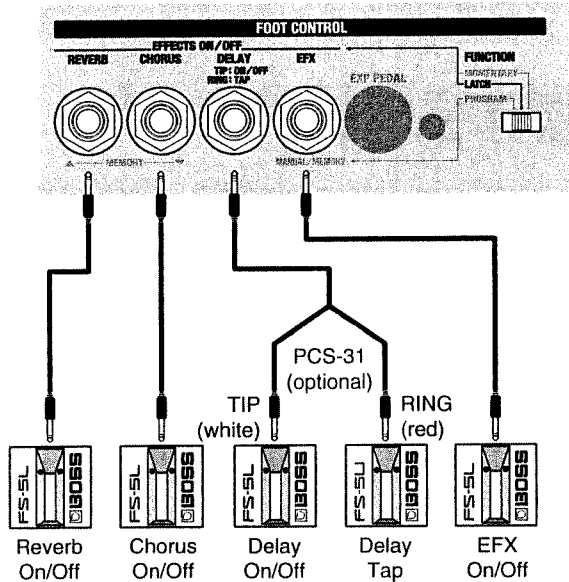

In this case, you can check the effects' on/off status with the FS-5L's indicators.

- * Connect BOSS FS-5L foot switches (optional). However, when using the Tap function, connect a BOSS FS-5U (optional) to DELAY TAP (RING).
- * When a single foot switch is connected with one cable to the DELAY jack, the switch is used for switching the delay on and off.

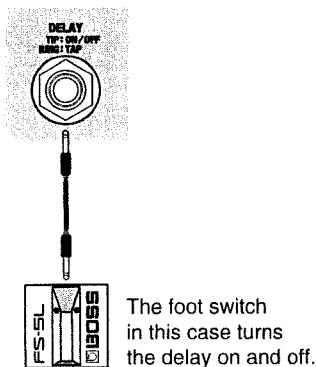

Using Foot Switches to Switch Memories

PROGRAM

You can switch between Manual and Memory modes, as well as switch memory numbers.

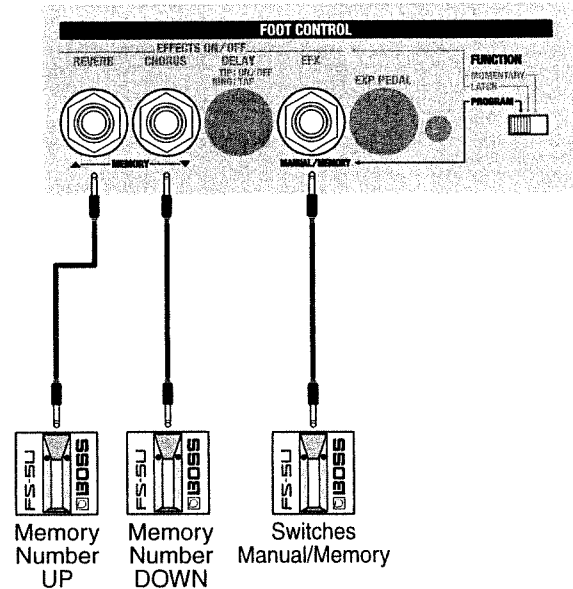

- * Connect only BOSS FS-5U foot switches (optional).

Notes Regarding Foot Switches

- * Connecting a foot switch while the power is on may switch effects on or off, switch memories, or cause the VGA-5 to switch between Manual and Memory modes.
- * When using the FS-5U or FS-5L foot switches (optional), set the polarity switch as shown below.

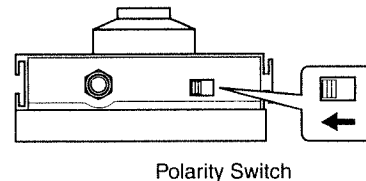

6 MIDI

MIDI IN Connector

With a foot controller (such as the optional GFC-50 or FC-200) connected, you can use your foot to switch memories (p. 24).

About the Memory Function

You can store and call up ten knob and button settings used to operate the VGA-5.

Additionally, if you use a foot controller (the GFC-50 or FC-200: optional), you can store and call up forty knob and button settings (p. 24).

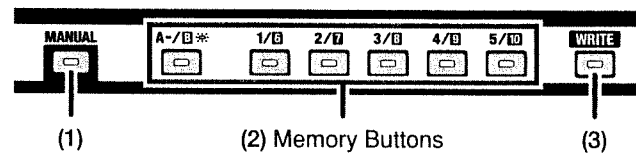

Calling Up Memory

Press memory button (2) to select the memory to be called up.

When [A/B] is not lighted, the memories numbered from 1 through 5 can be selected (in the illustration, Memory 1 is selected).

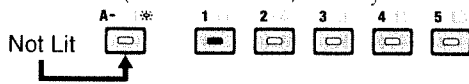

When [A/B] is lit, the memories numbered from 6 through 10 can be selected (in the illustration, Memory 6 is selected).

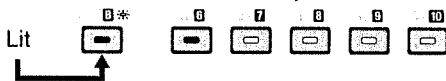

Changing the Memory Settings (Edit)

1. Press memory button (2) to select the memory whose settings are to be changed.
2. Operate the knobs/buttons.
When you change the knob or button settings, the button indicator corresponding to the selected memory flashes.

MEMO

When turning a knob, the value stored in the memory changes after the knob reaches the knob position corresponding to that stored value. Thus you should first make a wide sweep with the knob, then remake the setting.

NOTE

If before the setting is stored the mode is switched to Manual or Memory or the power is turned off, all changes in the values are deleted. Whenever working with important settings, be sure to use the Write operation.

Storing Knob and Button Settings to Memory (Write)

1. When you have finished making the knob and/or button settings, press [WRITE] (3), causing the indicator to light.
2. Press memory button (2) for the memory that you want to contain the settings.
** If you want to cancel the Write operation, press [MANUAL] (1).*
3. Press [WRITE] (3) once more to execute writing.
During the write, the [WRITE] indicator flashes rapidly; the write is completed when the [WRITE] indicator stops flashing and stays off.

Using the GFC-50 to Operate the VGA-5

By connecting a GFC-50 foot controller (optional), you can use your foot to operate the VGA-5.

Use the VGA-5's factory MIDI settings.

Connecting the VGA-5 and the GFC-50

Connect the VGA-5 and the GFC-50 with a MIDI cable.

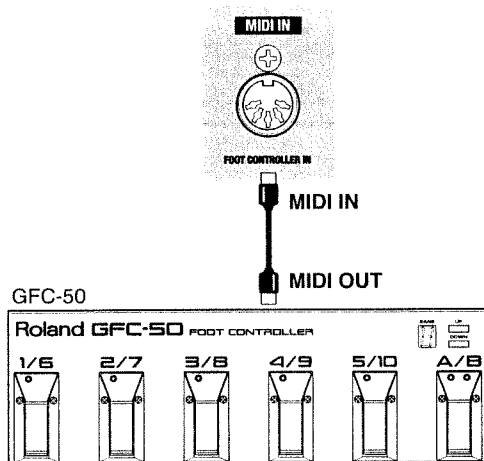

Switching Memories With the GFC-50

The VGA-5's forty memories are divided up into Banks 0, 1, 2, and 3 as shown below.

You can use the GFC-50 to call up and store (write) settings in all of the memories.

The forty memories can be accessed by specifying them in terms of the GFC-50's banks (0-3) and numbers (1-10).

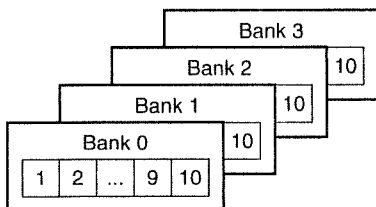

Of these, panel operations on the VGA-5 can be employed to store and call up settings for Memory Nos. 1-10 of Bank 0.

How to Call Up the VGA-5's Memories Using the GFC-50

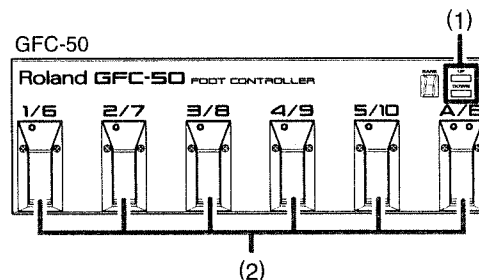

1. Press the GFC-50's Bank button (1) to select from Banks 0, 1, 2, or 3.
2. Select a memory Number 1-10 with the GFC-50's pedal (2).

Here, the memory number selected with the pedal is also indicated by the VGA-5's memory button indicator.

* If Bank 1, 2, or 3 is specified with the foot controller, and the power is turned off and then on again, the VGA-5's memory still returns to Bank 0.

Storing to the VGA-5's Memories Using the GFC-50

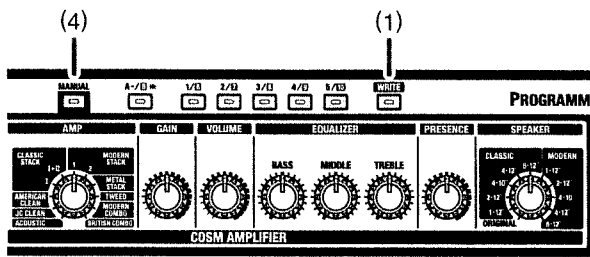

VGA-5 Panel

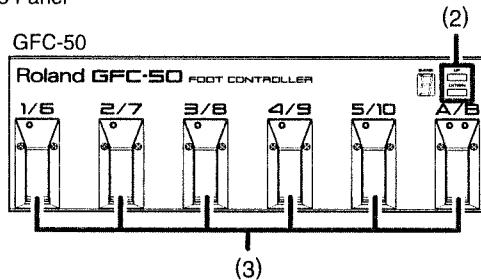

(3)

1. Using the VGA-5's knobs and buttons, prepare a tone you want to store.
 2. Press the VGA-5's **[WRITE]** (1) button, causing the indicator to flash.
 3. Press the pedal (2) to select which of the Banks 0-3 in which you want to write the tone.
 4. Press the pedal (3) to select which of the memory numbers 1-10 to which you want to write the tone.
- * If you want to cancel, press the VGA-5's **[MANUAL]** (4).
5. Press the VGA-5's **[WRITE]** (1) once more.
- During the write, the **[WRITE]** indicator flashes rapidly; the write is completed when the **[WRITE]** indicator stops flashing and stays off.

Control Using an External Foot Switch or Pedal

Connecting an external foot switch or expression pedal to the VGA-5 allows you to use your foot to control the following VGA-5 functions.

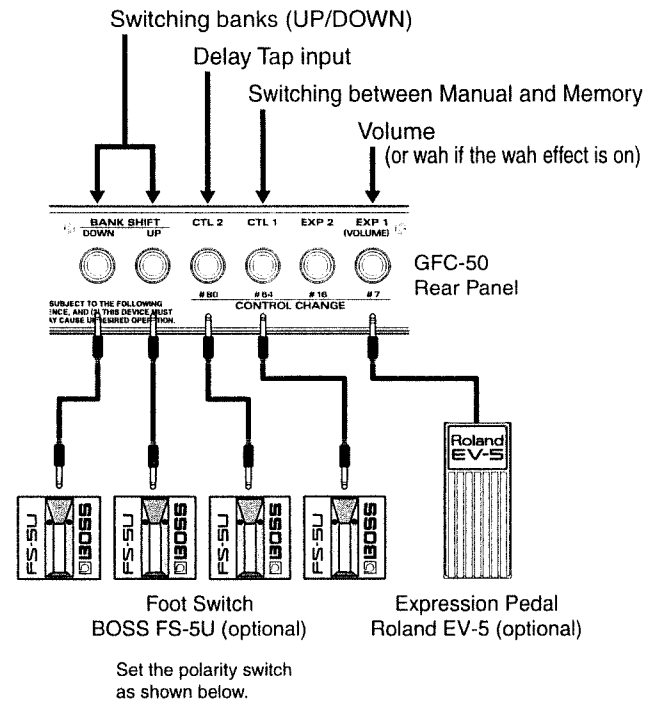

* If the expression pedal does not function with the above connections (p. 28), restore the original factory settings.

Pedal Hold Function and MIDI Settings

You can use an expression pedal and MIDI to make settings on the VGA-5.

Pedal Hold Function Settings

Select the pedal function for the expression pedal.

Pedal Hold On:

When switching memories, the volume corresponds to the pedal position.

Pedal Hold Off:

When switching memories, the volume set in the memory is used. The pedal function is enabled after the pedal is pressed all the way down, or is completely released.

MIDI Settings

- Omni Mode (MIDI Receive Channel) On/Off Setting
- Volume/Wah Control Number Setting

Use the following procedure for the Pedal Hold function settings and the MIDI-related settings.

1. Hold down **[MANUAL]** while you switch ON the POWER switch.
2. Press the button for the functions you want to set, lighting or extinguishing indicators as needed.

The correspondence between **[EFX]**, **[TAP]**, **[DELAY]**, **[CHORUS]**, and **[REVERB]** and the functions that are set is shown below.

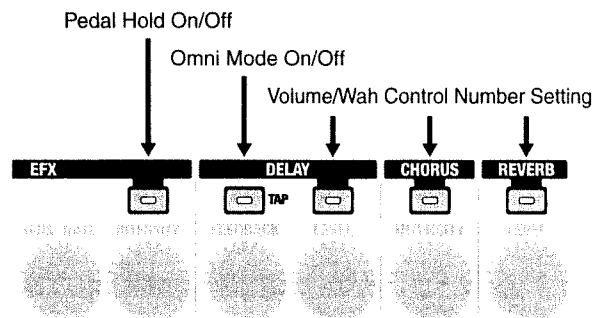

3. When you have finished making the setting, press **[MANUAL]**.

The setting is stored, and the VGA-5 returns to its normal operation status.

* These settings are stored in the VGA-5 even without use of the Write operation.

Pedal Hold On/Off Setting

You can set the function of an expression pedal (optional Roland EV-5 or BOSS FV-300L) when the pedal is connected to the VGA-5.

The diagram shows the EFX button with a small indicator light. An arrow points from the indicator light to a text box.

Lit: Pedal Hold On
When switching memories, the volume corresponds to the pedal position.

Not Lit: Pedal Hold Off
When switching memories, the volume set in the memory is used. The pedal function is enabled after the pedal is pressed all the way down, or is completely released.

* Pedal Hold is set to ON at the factory settings.

Omni Mode On/Off Setting

You can set the VGA-5 MIDI channel setting to Omni On, whereby it can receive data on any channel, or Omni Off (set at Channel 1).

The diagram shows the DELAY button with a small indicator light and a TAP button. An arrow points from the indicator light to a text box.

Lit: Data can be received on any channel (Omni On).

Not Lit: Only MIDI Channel 1 is used (Omni Off).
This will function only with the channel on the transmitting MIDI device set to 1.

* The VGA-5's MIDI channel cannot be changed.
* Omni ON is selected in the factory settings.

Volume/Wah Control Number Setting

When the control numbers for the VGA-5 (the receiving device) and the foot controller (the transmitting device) are matched, you can control volume and wah with the foot controller.

With the VGA-5, you can select from the following three volume and wah control numbers.

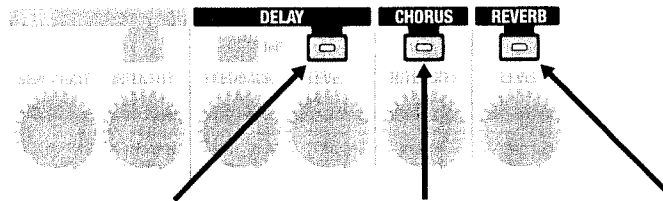

	When the DELAY Indicator is Lit	When the CHORUS Indicator is Lit	When the REVERB Indicator is Lit
Pedal Function	With a single expression pedal connected, you can use it as a wah pedal when the wah effect is on, and a volume pedal when wah is off.	Select this setting when connecting two expression pedals and using them for independent control of the volume and wah.	With two expression pedals connected, you can use them to control the volume, except for Number 7.
Volume Control Number	No. 7	No. 7	No. 4
Wah Control Number	No. 7	No. 16	No. 16

* Set the above control numbers in the transmitting device as well.

Regarding Other Control Number Correspondences

The VGA-5 also handles the following control numbers.

- Switching Manual/Memory (No. 64)
- EFX On/Off (No. 65)
- Delay On/Off (No. 66)
- Chorus On/Off (No. 67)
- Reverb On/Off (No. 68)
- Tap Input (No. 80)

* The control numbers are fixed.

What are Control Numbers?

These are the Control Change numbers (MIDI messages) transmitted when the foot controller is operated.

Appendices

Restoring the Factory Settings

You can return the VGA-5's forty memories, Pedal Hold, MIDI settings, and noise suppressor to their original settings as shipped from the factory.



Returning the VGA-5 to its factory settings deletes any previously created data.

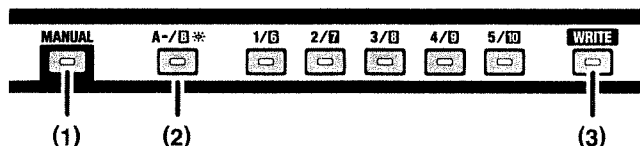

When Restoring All of the Factory Settings

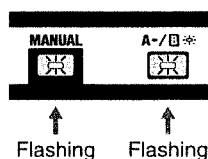

* The tone settings in the memories all revert to those listed in the "VGA-5 MEMORY SHEET" (p. 32).

1. Hold down **[WRITE]** (3) while you switch ON the POWER switch.

[MANUAL] and **[A/B]** flash.

* If you want to cancel the operation, press a memory number button.

2. Press **[WRITE]** (3).

The **[WRITE]** indicator flashes; when the setting is completed, the VGA-5 returns to memory Number 1.

When Restoring the Pedal Hold, MIDI Settings, and Noise Suppressor to Their Factory Settings

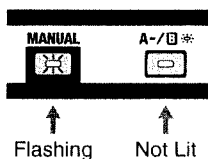

1. Hold down **[WRITE]** (3) while you switch ON the POWER switch.

[MANUAL] and **[A/B]** flash.

2. Press **[A/B]** (2), extinguishing the indicator.

Now, only the **[MANUAL]** indicator flashes.

* If you want to cancel the operation, press a memory number button.

3. With the **[MANUAL]** indicator flashing, press **[WRITE]** (3).

The **[WRITE]** indicator flashes; when the setting is completed, the VGA-5 returns to memory Number 1.

When Restoring Only the Memories to Their Factory Settings

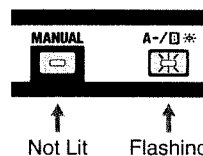

* The tone settings in the memories all revert to those listed in the "VGA-5 MEMORY SHEET" (p. 32).

* Hold down **[WRITE]** (3) while you switch ON the POWER switch.

[MANUAL] and **[A/B]** flash.

4. Press **[MANUAL]** (1), extinguishing the indicator.

Now only the **[A/B]** indicator flashes.

* If you want to cancel the operation, press a memory number button.

5. With the **[A/B]** indicator flashing, press **[WRITE]** (3).

The **[WRITE]** indicator flashes; when the setting is completed, the VGA-5 returns to memory Number 1.

Calling Up the Factory Tone Settings for Each Individual Bank

You can select any one of the Banks 0–3 listed on the Memory Sheet (p. 32) and call up that bank’s factory-loaded tone settings to memory buttons 1–10.

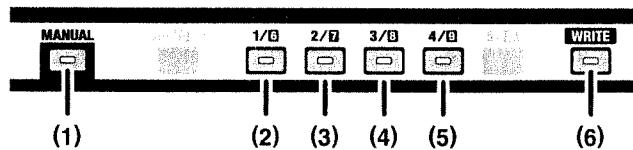

1. While holding down the memory button corresponding to the bank on the Memory Sheet that you want to call up, switch ON the POWER switch.

To call up the Memory Sheet Bank 0 tone settings: [1/6] (2)

To call up the Memory Sheet Bank 1 tone settings: [2/7] (3)

To call up the Memory Sheet Bank 2 tone settings: [3/8] (4)

To call up the Memory Sheet Bank 3 tone settings: [4/9] (5)

For example, if you want to call up the tone settings for Bank 2 on the Memory Sheet, hold down [3/8] (4) and switch the power on. The [3/8] indicator flashes.

* If you want to cancel the operation, press [MANUAL] (1).

2. Press [WRITE] (6).

The [WRITE] indicator flashes; once the settings have been called up, the VGA-5 returns to memory Number 1.

* Calling up these settings clears all of the Memories 1–10 previously stored in Bank 0.

Problems With the Sound

This section explains some things that might go wrong when using the VGA-5, and what needs to be done to correct the problem. If you think there may be something wrong with your VGA-5, please check through the following first. If these suggestions don't fix the problem, then go ahead and contact the store you bought it from, or your nearest Roland Service Station.

Trouble with the Sound

Odd Sound / No Sound When Guitar Is Played

- Is the value for the [MASTER], [GAIN], or [VOLUME] knobs, or for the [GAIN] or [VOLUME] settings stored in the memory set to "0"?
 - Raise the volume to a suitable level.
- Are the [BASS], [MIDDLE], or [TREBLE] knobs set to "0"?
 - Depending on the model selected with the Amp Type switch (p. 16), no sound may be produced when [BASS], [MIDDLE], and [TREBLE] are all set to "0."
- Are you using an expression pedal?
 - There may be no sound produced when the pedal portion is set to the released position. Try operating the pedal.
- If controlling the volume with MIDI, was the MIDI connection disrupted while the volume was set to "0"?
 - Reconnect the MIDI device and raise the volume, or turn the VGA-5's power off and then on again.

Internal Effects Not Being Applied

- Are the effects set to "OFF"?
 - When an effect is set to "OFF," that effect is not added to the sound. Set to "ON."
- Is the effect level turned completely down?
 - When delay or reverb level is set to the minimum setting, the effect is not applied, and only the source sound (direct sound) is played. Set the delay or reverb level to an appropriate value.

Interruptions in the Sound

- Is the noise suppressor effect set near "10" (deep effect)?
 - Make a shallower noise suppressor effect setting (p. 13).

Problems Concerning the Internal Battery

[EFX]/[TAP]/[DELAY]/[CHORUS]/[REVERB] Indicators Flash When Power Is Turned On

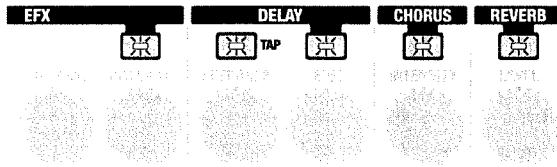

- The internal battery used for saving the memories and settings is nearly worn out. While the memories and settings have not yet been lost at this point, the battery will have to be replaced soon. Consult Roland Service or your local instrument dealer.

Other Problems

VGA-5 Receives Commands from Foot Controller or Other Device, But Memories Do Not Switch

- Is the external device transmitting over a MIDI channel that cannot be received by the VGA-5?
- Set the MIDI channel on the external device to Channel 1. Otherwise, set MIDI (OMNI) in the VGA-5's MIDI settings to ON (p. 26).

The volume level of the instrument connected to EXT IN is too low.

- Could you be using a connection cable that contains a resistor?
- Use a connection cable that does not contain a resistor.

Pressing Effects Buttons Does Not Turn Effects On/Off

- Is the FUNCTION switch set to LATCH?
- When the FUNCTION switch is set to LATCH and a foot switch is connected, the effects can be turned on and off only with the foot switch.

[TAP] Indicator Does Not Flash

- Is the delay variation set to HOLD?
- When "HOLD" is selected, the [TAP] indicator lights up only during recording (p. 19).

Foot Switch Does Not Operate Correctly

- Is the FUNCTION switch setting the right one for the connected foot switch?
- When the FUNCTION switch is set to "MOMENTARY" or "PROGRAM," use the BOSS FS-5U (optional). When set to "LATCH," use the BOSS FS-5L (optional) (p. 21).

[MANUAL] Indicator Flashes With MIDI Device In Use

- Could the external MIDI device have transmitted a large volume of data all at once?
- After the indicator flashes for a short while, the VGA-5 automatically returns to the condition it was in before receiving the data. Reduce the amount of data that will be transmitted by the external device, then have it send the data again.

Block Diagram/Effect Connection Procedure

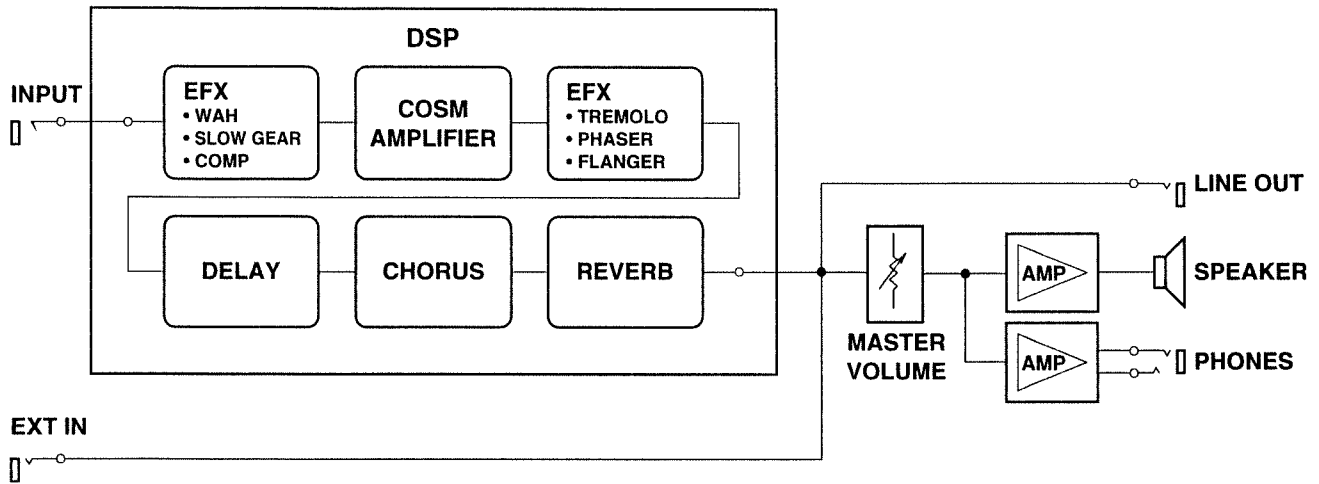

* An EFX effect is placed either before or after the COSM amplifier, depending on the effect selected.

VGA-5 Memory Sheet (Factory tone settings)



Memories that can be called up with VGA-5's panel switch:

BANK0	1	2	3	4	5
	American Lead	Thrash Metal	Dark Chorus	Tweed Blues	Bright Acoustic
	6	7	8	9	10
	Rockabilly	British HR Lead	Flange Metal	Modern Funk	Backward FX

Memories of BANK 1-3 can be called up by connecting a MIDI foot controller (GFC-50, FC-200: optional). (p. 24)

BANK1	1	2	3	4	5
	Modern Combo Crunch	Mellow Clean	Small Tweed	Crunchy Liverpool	Chorus Acoustic
	6	7	8	9	10
	British HR : Top Boost	American HR Lead	Super Tweed	Swampy Tube	Super Metal

BANK2	1	2	3	4	5
	Modern Stack : High Gain	Bright Liverpool	California MKII Lead	Heavy Bottom Metal	Mid-boost Metal
	6	7	8	9	10
	Thick Jazz Twin	Fat Twin	Vintage Tweed	Classic Stack I	Rich Acoustic

BANK3	1	2	3	4	5
	Classic Stack	British Crunch	American Clean	JC Chorus	Tweed Crunch
	6	7	8	9	10
	Metal Stack	American Modern Stack	British Clean	American Metal Stack	Acoustic

V-GUITAR AMPLIFIER

Date : Nov. 1, 2000

Model VGA-5

MIDI Implementation Chart

Version : 1.00

Function...	Transmitted	Recognized	Remarks
Basic Channel	Default X Changed X	1-16 X	Fixed channel 1
Mode	Default X Messages X Altered *****	OMNI ON/OFF X	Memorized
Note Number :	True Voice X *****	X	
Velocity	Note ON X Note OFF X	X X	
After Touch	Key's X Ch's X	X X	
Pitch Bend	X	X	
Control Change	7, (4) X	O	Volume *1
	7, (16) X	O	Wah *1
	64 X	O	Manual/Memory
	65 X	O	EFX
	66 X	O	Delay
	67 X	O	Chorus
	68 X	O	Reverb
	80 X	O	Tap
Prog Change	: True # X X	O 1-40	
System Exclusive	X	X	
System Common	: Song Pos X : Song Sel X : Tune X	X X X	
System Real Time	: Clock X : Command X	X X	
Aux Message	: All sound off X : Local ON/OFF X : All Notes OFF X : Active Sense X : Reset X	X X X X X	
Notes	* 1 Depends on extension pedal. () Those appearing in parentheses can be selected.		

Mode 1 : OMNI ON, POLY

Mode 2 : OMNI ON, MONO

O : Yes

Mode 3 : OMNI OFF, POLY

Mode 4 : OMNI OFF, MONO

X : No

Specifications

VGA-5: V-Guitar Amplifier

● Rated Power Output

65 W

● Memories

10 (Recalled from Panel)

40 (Recalled from Foot Controller)

● Nominal Input Level (1 kHz)

INPUT HIGH: -10 dBu / 470 kΩ

INPUT LOW: 0 dBu / 220 kΩ

EXT IN: +4 dBu

● Nominal Output Level

LINE OUT: +4 dBu

(0 dBu = 0.775 V rms)

● Speaker

12 inch (30 cm) x 1

● Controls

COSM AMPLIFIER

AMP TYPE switch

GAIN knob

VOLUME knob

EQUALIZER: BASS knob
MIDDLE knob
TREBLE knob

PRESENCE knob

SPEAKER TYPE switch

EFFECTS

EFX: ON/OFF button
TYPE switch
SENS/RATE knob
INTENSITY knob

DELAY: ON/OFF button
TAP button
FEEDBACK knob
LEVEL knob

CHORUS: ON/OFF button
INTENSITY knob

REVERB: ON/OFF button
LEVEL knob

MASTER knob

MANUAL button

Memory buttons (A/B, 1/6 – 5/10)

WHITE button

POWER switch

FUNCTION SWITCH (rear)

● Connectors

INPUT jacks (HIGH, LOW)

PHONES jack

EXT IN jack

LINE OUT jack

FOOT CONTROL

EXP PEDAL jack

EFX / MANUAL-MEMORY jack

DELAY jack (TIP: ON/OFF, RING: TAP)

CHORUS / MEMORY ▼ jack

REVERB / MEMORY ▲ jack

MIDI IN connector

● Power Supply

AC 117V, 230 V, 240 V

● Power Consumption

75 W (117 V, 230 V, 240 V)

● Dimensions

650 (W) x 290 (D) x 540 (H) mm

25-5/8 (W) x 11-7/16 (D) x 21-5/16 (H) inches

(Include casters)

● Weight

24.0 kg / 52 lbs 15 oz

● Accessories

Owner's Manual

● Options

Expression Pedal: EV-5, FV-300L

Foot Switch: BOSS FS-5U, FS-5L

Foot Controller: GFC-50, FC-200



In the interest of product improvement, the specifications and/or appearance of this unit are subject to change without prior notice.

For EU Countries

Apparatus containing Lithium batteries

ADVARSEL!

Lithiumbatteri - Eksplosionsfare ved fejlagtig håndtering.
Udskiftning må kun ske med batteri af samme fabrikat og type.
Levér det brugte batteri tilbage til leverandøren.

ADVARSEL

Eksplosjonsfare ved feilaktig skifte av batteri.
Benytt samme batteritype eller en tilsvarende type anbefalt av apparatfabrikanten.
Brukte batterier kasseres i henhold til fabrikantens instruksjoner.

CAUTION

Danger of explosion if battery is incorrectly replaced.
Replace only with the same or equivalent type recommended by the manufacturer.
Discard used batteries according to the manufacturer's instructions.

VARNING

Eksplosionsfara ved felaktigt batteribyte.
Använd samma batterityp eller en ekvivalent typ som rekommenderas av apparatillverkaren.
Kassera använt batteri enligt fabrikantens instruktion.

VAROITUS

Paristo voi räjähtää, jos se on virheellisesti asennettu.
Vaihda paristo ainoastaan laitevalmistajan suosittelemaan tyyppiin. Hävitä käytetty paristo valmistajan ohjeiden mukaisesti.

For EU Countries



This product complies with the requirements of European Directives EMC 89/336/EEC and LVD 73/23/EEC.

For the USA

FEDERAL COMMUNICATIONS COMMISSION RADIO FREQUENCY INTERFERENCE STATEMENT

This equipment has been tested and found to comply with the limits for a Class B digital device, pursuant to Part 15 of the FCC Rules. These limits are designed to provide reasonable protection against harmful interference in a residential installation. This equipment generates, uses, and can radiate radio frequency energy and, if not installed and used in accordance with the instructions, may cause harmful interference to radio communications. However, there is no guarantee that interference will not occur in a particular installation. If this equipment does cause harmful interference to radio or television reception, which can be determined by turning the equipment off and on, the user is encouraged to try to correct the interference by one or more of the following measures:

- Reorient or relocate the receiving antenna.
- Increase the separation between the equipment and receiver.
- Connect the equipment into an outlet on a circuit different from that to which the receiver is connected.
- Consult the dealer or an experienced radio/TV technician for help.

Unauthorized changes or modification to this system can void the users authority to operate this equipment.
This equipment requires shielded interface cables in order to meet FCC class B Limit.

For Canada

NOTICE

This Class B digital apparatus meets all requirements of the Canadian Interference-Causing Equipment Regulations.

AVIS

Cet appareil numérique de la classe B respecte toutes les exigences du Règlement sur le matériel brouilleur du Canada.

Information

When you need repair service, call your nearest Roland Service Center or authorized Roland distributor in your country as shown below.

AFRICA

EGYPT

Al Fanny Trading Office
P.O. Box 2904,
El Horrieh Heliopolis, Cairo,
EGYPT
TEL: (02) 4185531

REUNION

Maison FO - YAM Marcel
25 Rue Jules Hermann,
Chaudron - BP79 97 491
Ste Clotilde Cedex,
REUNION ISLAND
TEL: 28 29 16

SOUTH AFRICA

That Other Music Shop (PTY) Ltd.
11 Melle St., Braamfontein,
Johannesbourg
Republic of SOUTH AFRICA

P.O.Box 32918, Braamfontein 2017
Republic of SOUTH AFRICA
TEL: (011) 403 4105

Paul Bothner (PTY) Ltd.
17 Werdmuller Centre Claremont
7700
Republic of SOUTH AFRICA

P.O. Box 23032
Claremont, Cape Town
SOUTH AFRICA, 7735
TEL: (021) 674 4030

ASIA

CHINA

Beijing Xinghai Musical Instruments Co., Ltd.
6 Huangmuchiang Chao Yang
District, Beijing, CHINA
TEL: (010) 6774 7491

HONG KONG

Tom Lee Music Co., Ltd. Service Division
22-32 Pun Shan Street, Tsuen
Wan, New Territories,
HONG KONG
TEL: 2415 0911

INDIA

Rivera Digitec (India) Pvt. Ltd.
409, Nirman Kendra Mahalaxmi
Flats Compound Off. Dr. Edwin
Moses Road, Mumbai-400011,
INDIA
TEL: (022) 498 3079

INDONESIA

PT Citra Inti Rama
Jl. Cideng Timur No. 15J-150
Jakarta Pusat
INDONESIA
TEL: (021) 6324170

KOREA

Cosmos Corporation
1461-9, Seocho-Dong,
Seocho Ku, Seoul, KOREA
TEL: (02) 3486-8855

MALAYSIA

Bentley Music SDN BHD
140 & 142, Jalan Bukit Bintang
55100 Kuala Lumpur, MALAYSIA
TEL: (03) 2443333

PHILIPPINES

G.A. Yupangco & Co. Inc.
339 Gil J. Puyat Avenue
Makati, Metro Manila 1200,
PHILIPPINES
TEL: (02) 899 9801

SINGAPORE

Swee Lee Company
150 Sims Drive,
SINGAPORE 387381
TEL: 748-1669

CRISTOFORI MUSIC PTE LTD
Blk 3014, Bedok Industrial Park E,
#02-2148, SINGAPORE 489980
TEL: 243 9555

TAIWAN

ROLAND TAIWAN ENTERPRISE CO., LTD.
Room 5, 9th. No. 112 Chung Shan
N.Road Sec.2, Taipei, TAIWAN,
R.O.C.
TEL: (02) 2561 3339

THAILAND

Theera Music Co., Ltd.
330 Verng NakornKasem, Soi 2,
Bangkok 10100, THAILAND
TEL: (02) 2248821

VIETNAM

Saigon Music
138 Tran Quang Khai St.,
District 1
Ho Chi Minh City
VIETNAM
TEL: (08) 844-4068

AUSTRALIA/ NEW ZEALAND

AUSTRALIA

Roland Corporation Australia Pty., Ltd.
38 Campbell Avenue
Dee Why West, NSW 2099
AUSTRALIA
TEL: (02) 9982 8266

NEW ZEALAND

Roland Corporation (NZ) Ltd.
97 Mt. Eden Road, Mt. Eden,
Auckland 3, NEW ZEALAND
TEL: (09) 3098 715

CENTRAL/LATIN AMERICA

ARGENTINA

Instrumentos Musicales S.A.
Florida 656 2nd Floor
Office Number 206A
Buenos Aires
ARGENTINA, CP1005
TEL: (54-11) 4- 393-6057

BRAZIL

Roland Brasil Ltda.
R. Coronel Octaviano da Silveira
203 05522-010
Sao Paulo BRAZIL
TEL: (011) 3743 9377

COSTA RICA

JUAN Bansbach Instrumentos Musicales
Ave.1. Calle 11, Apartado 10237,
San Jose, COSTA RICA
TEL: (506)258-0211

CHILE

Comercial Fancy S.A.
Avenida Rancagua #0330
Providencia Santiago, CHILE
TEL: 56-2-373-9100

EL SALVADOR OMNI MUSIC

75 Avenida Notre YY Alameda,
Juan Pablo 2, No. 4010
San Salvador, EL SALVADOR
TEL: (503) 262-0788

MEXICO

Casa Veerkamp, s.a. de c.v.
Av. Toluca No. 323, Col. Olivar
de los Padres 01780 Mexico D.F.
MEXICO
TEL: (525) 668 04 80

La Casa Wagner de Guadalupe s.a. de c.v.
Av. Corona No. 202 S.J.
Guadalupe, Jalisco Mexico
C.P.41100 MEXICO
TEL: (3) 613 1414

PANAMA

SUPRO MUNDIAL, S.A.
Boulevard Andrews, Albrook,
Panama City,
REP. DE PANAMA
TEL: (507) 315-0101

PARAGUAY

Distribuidora De Instrumentos Musicales
J.E. Olear y ESQ. Manduvira
Edeficio, El Dorado Planta Baja
Asamcion PARAGUAY
TEL: 595-21-492147

PERU

VIDEO Broadcast S.A.
Portinari 199 (ESQ. HIALS),
San Borja, Lima 41,
REP. OF PERU
TEL: 51-14-758226

URUGUAY

Todo Musica S.A.
Cuareim 1844, Montevideo,
URUGUAY, CP11200
TEL: 5982-924-2335

VENEZUELA

Musiland Digital C.A.
Av. Francisco de Miranda,
Centro Parque de Cristal, Nivel
C2 Local 20 Caracas
VENEZUELA
TEL: (02) 285 9218

EUROPE

AUSTRIA

Roland Austria GES.M.B.H.
Siemensstrasse 4, P.O. Box 74,
A-6063 RUM, AUSTRIA
TEL: (0512) 26 44 260

BELGIUM/HOLLAND/ LUXEMBOURG

Roland Benelux N. V.
Houtstraat 3, B-2260, Oevel
(Western) BELGIUM
TEL: (014) 575811

DENMARK

Roland Scandinavia A/S
Nordhavnsvej 7, Postboks 880,
DK-2100 Copenhagen
DENMARK
TEL: (039)16 6200

FRANCE

Roland France SA
4, Rue Paul Henri SPAAK,
Parc de l'Esplanade, F 77 462 St.
Thibault, Lagny Cedex FRANCE
TEL: 01 600 73 500

FINLAND

Roland Scandinavia As, Filial Finland
Lautasaarentie 54 B
Fin-00201 Helsinki, FINLAND
TEL: (9) 682 4020

GERMANY

Roland Elektronische Musikinstrumente HmbH.
Oststrasse 96, 22844 Norderstedt,
GERMANY
TEL: (040) 52 60090

GREECE

STOLLAS S.A. Music Sound Light
155, New National Road
26422 Patras, GREECE
TEL: 061-435400

HUNGARY

Intermusica Ltd.
Warehouse Area 'DEPO' PE.83
H-2046 Torokbalint, HUNGARY
TEL: (23) 511011

IRELAND

Roland Ireland
Audio House, Belmont Court,
Donnybrook, Dublin 4,
Republic of IRELAND
TEL: (01) 2603501

ITALY

Roland Italy S. p. A.
Viale delle Industrie 8,
20020 Arese, Milano, ITALY
TEL: (02) 937-78300

NORWAY

Roland Scandinavia Avd. Kontor Norge
Lilleakerveien 2 Postboks 95
Lilleaker N-0216 Oslo
NORWAY
TEL: 273 0074

POLAND

P. P. H. Brzostowicz
Ul. Gibraltarska 4,
PL-03664 Warszawa POLAND
TEL: (022) 679 44 19

PORTUGAL

Tecnologias Musica e Audio, Roland Portugal, S.A.
RUA DE SANTA CARARINA
131/133, 4000-450 PORTO
PORTUGAL
TEL: (022) 208 4456

ROMANIA

FBS LINES
Plata Libertatii 1,
RO-4200 Cheorgheni
TEL: (066) 164-609

RUSSIA

Slami Music Company
Sadojava-Triumfalnaja st., 16
103006 Moscow, RUSSIA
TEL: 095 209 2193

SPAIN

Roland Electronics de España, S. A.
Calle Bolivia 239, 08020
Barcelona, SPAIN
TEL: (93) 308 1000

SWEDEN

Roland Scandinavia A/S SWEDISH SALES OFFICE
Danvik Center 28, 2 tr.
S-131 30 Nacka SWEDEN
TEL: (08) 702 0020

SWITZERLAND

Roland (Switzerland) AG Musitronic AG
Gerberstrasse 5, Postfach,
CH-4410 Liestal, SWITZERLAND
TEL: (061) 921 1615

UKRAINE

TIC-TAC
Mira Str. 19/108
P.O. Box 180
295400 Munkachevo, UKRAINE
TEL: (03131) 414-40

UNITED KINGDOM

Roland (U.K.) Ltd.
Atlantic Close, Swansea
Enterprise Park, SWANSEA
SA7 9FJ,
UNITED KINGDOM
TEL: (01792) 700139

MIDDLE EAST

BAHRAIN

Moon Stores
Bab Al Bahrain Road,
P.O. Box 20077
State of BAHRAIN
TEL: 211 005

CYPRUS

Radex Sound Equipment Ltd.
17 Diagorou St., P.O. Box 2046,
Nicosia CYPRUS
TEL: (02) 453 426

ISRAEL

Haliit P. Greenspoon & Sons Ltd.
8 Retzif Ha'aliya Hashnya St.
Tel-Aviv-Yafa ISRAEL
TEL: (03) 6823666

JORDAN

AMMAN Trading Agency
Prince Mohammed St. P.O. Box
825 Amman 11118 JORDAN
TEL: (06) 4641200

KUWAIT

Easa Husain Al-Yousifi
Abdullah Salem Street,
Safat KUWAIT
TEL: 5719499

LEBANON

A. Chahine & Fils
P.O. Box 16-5857 Gergi Zeidan St.
Chahine Building, Achrafieh
Beirut, LEBANON
TEL: (01) 335799

QATAR

Al Emadi Co. (Badie Studio & Stores)
P.O. Box 62,
DOHA QATAR
TEL: 4423-554

SAUDI ARABIA

aDawlah Universal Electronics APL
Corniche Road, Aldossary Bldg.,
1st Floor
SAUDI ARABIA

P.O.Box 2154, Alkhobar 31952
SAUDI ARABIA
TEL: (03) 898 2081

SYRIA

Technical Light & Sound Center
Khaled Ibn Al Walid St.
P.O. Box 13520
Damascus - SYRIA
TEL: (011) 2235 384

TURKEY

Barkat muzik aletleri ithalat ve ihracat Ltd Sti
Siraselviler cad.Guney is hani 84-
86/6, Taksim, Istanbul. TURKEY
TEL: (0212) 2499324

U.A.E.

Zak Electronics & Musical Instruments Co. L.L.C.
Zabeel Road, Al Sherouq Bldg.,
No. 14, Grand Floor DUBAI
U.A.E.
TEL: (04) 3360715

NORTH AMERICA

CANADA

Roland Canada Music Ltd. (Head Office)
5480 Parkwood Way Richmond
B.C., V6V 2M4 CANADA
TEL: (604) 270 6626

Roland Canada Music Ltd. (Toronto Office)
Unit 2, 109 Woodbine Downs
Blvd, Etobicoke, ON
M9W 6Y1 CANADA
TEL: (416) 213 9707

U. S. A.

Roland Corporation U.S.
5100 S. Eastern Avenue
Los Angeles, CA 90040-2938,
U. S. A.
TEL: (323) 890 3700

As of November 1, 2000 (Roland)

 Roland®

MANUA00053

UPC

MANUA00053



10981

Roland