



*3 IN/3 OUT/3 THRU USB MIDI INTERFACE*

# **UM-3EX**

## **Owner's Manual Bedienungsanleitung Mode d'emploi Manuale d'uso Manual del usuario**

Thank you, and congratulations on your choice of the UM-3EX USB MIDI Interface.



Before using this unit, carefully read the sections entitled: "USING THE UNIT SAFELY" and "IMPORTANT NOTES" (p. 2; p. 4). These sections provide important information concerning the proper operation of the unit. Additionally, in order to feel assured that you have gained a good grasp of every feature provided by your new unit, Owner's manual should be read in its entirety. The manual should be saved and kept on hand as a convenient reference.



Copyright © 2005 ROLAND CORPORATION

All rights reserved. No part of this publication may be reproduced in any form without the written permission of ROLAND CORPORATION.







# USING THE UNIT SAFELY

## INSTRUCTIONS FOR THE PREVENTION OF FIRE, ELECTRIC SHOCK, OR INJURY TO PERSONS

About  WARNING and  CAUTION Notices



|   |  |
|---|--|
|  <b>WARNING</b> | Used for instructions intended to alert the user to the risk of death or severe injury should the unit be used improperly.   |
|  <b>CAUTION</b> | Used for instructions intended to alert the user to the risk of injury or material damage should the unit be used improperly.<br>* Material damage refers to damage or other adverse effects caused with respect to the home and all its furnishings, as well to domestic animals or pets. |

About the Symbols



|   |  |
|---|--|
|  | The  symbol alerts the user to important instructions or warnings. The specific meaning of the symbol is determined by the design contained within the triangle. In the case of the symbol at left, it is used for general cautions, warnings, or alerts to danger.         |
|  | The  symbol alerts the user to items that must never be carried out (are forbidden). The specific thing that must not be done is indicated by the design contained within the circle. In the case of the symbol at left, it means that the unit must never be disassembled. |
|  | The  symbol alerts the user to things that must be carried out. The specific thing that must be done is indicated by the design contained within the circle. In the case of the symbol at left, it means that the power cord plug must be unplugged from the outlet.        |

### ALWAYS OBSERVE THE FOLLOWING

#### **WARNING**

- Before using this unit, make sure to read the instructions below, and the Owner's Manual. 
- Do not open or perform any internal modifications on the unit. 
- Do not attempt to repair the unit, or replace parts within it (except when this manual provides specific instructions directing you to do so). Refer all servicing to your retailer, the nearest Roland Service Center, or an authorized Roland distributor, as listed on the "Information" page. 

#### **WARNING**

- Never use or store the unit in places that are:
  - Subject to temperature extremes (e.g., direct sunlight in an enclosed vehicle, near a heating duct, on top of heat-generating equipment); or are
  - Damp (e.g., baths, washrooms, on wet floors); or are
  - Humid; or are
  - Exposed to rain; or are
  - Dusty; or are
  - Subject to high levels of vibration.
- This unit should be used only with a rack mount adaptor (RAF-70) that is recommended by Roland. 

## **WARNING**

- When using the unit with a rack or stand recommended by Roland, the rack or stand must be carefully placed so it is level and sure to remain stable. If not using a rack or stand, you still need to make sure that any location you choose for placing the unit provides a level surface that will properly support the unit, and keep it from wobbling.



- Connect only the specified device (UM-3EX) to the UM-3EX connectors.



- Do not allow any objects (e.g., flammable material, coins, pins); or liquids of any kind (water, soft drinks, etc.) to penetrate the unit.



- Immediately turn the power off, and request servicing by your retailer, the nearest Roland Service Center, or an authorized Roland distributor, as listed on the "Information" page when:
  - If smoke or unusual odor occurs
  - Objects have fallen into, or liquid has been spilled onto the unit; or
  - The unit has been exposed to rain (or otherwise has become wet); or
  - The unit does not appear to operate normally or exhibits a marked change in performance.



- Protect the unit from strong impact. (Do not drop it!)



## **WARNING**

- In households with small children, an adult should provide supervision until the child is capable of following all the rules essential for the safe operation of the unit.



- DO NOT play a CD-ROM disc on a conventional audio CD player. The resulting sound may be of a level that could cause permanent hearing loss. Damage to speakers or other system components may result.



## **CAUTION**

- Try to prevent cords and cables from becoming entangled. Also, all cords and cables should be placed so they are out of the reach of children.



- Never climb on top of, nor place heavy objects on the unit.



- Disconnect all cords coming from external devices before moving the unit.



- Should you remove screws, keep them in a safe place out of children's reach, so there is no chance of them being swallowed accidentally.



# IMPORTANT NOTES

In addition to the items listed under “USING THE UNIT SAFELY” on page p. 2, please read and observe the following:

## Power Supply

- Before connecting this unit to other devices, turn off the power to all units. This will help prevent malfunctions and/or damage to speakers or other devices.

## Placement

- This device may interfere with radio and television reception. Do not use this device in the vicinity of such receivers.
- Noise may be produced if wireless communications devices, such as cell phones, are operated in the vicinity of this unit. Such noise could occur when receiving or initiating a call, or while conversing. Should you experience such problems, you should relocate such wireless devices so they are at a greater distance from this unit, or switch them off.
- Do not expose the unit to direct sunlight, place it near devices that radiate heat, leave it inside an enclosed vehicle, or otherwise subject it to temperature extremes. Excessive heat can deform or discolor the unit.
- When moved from one location to another where the temperature and/or humidity is very different, water droplets (condensation) may form inside the unit. Damage or malfunction may result if you attempt to use the unit in this condition. Therefore, before using the unit, you must allow it to stand for several hours, until the condensation has completely evaporated.

## Maintenance

- For everyday cleaning wipe the unit with a soft, dry cloth or one that has been slightly dampened with water. To remove stubborn dirt, use a cloth impregnated with a mild, non-abrasive detergent. Afterwards, be sure to wipe the unit thoroughly with a soft, dry cloth.
- Never use benzene, thinners, alcohol or solvents of any kind, to avoid the possibility of discoloration and/or deformation.

## Additional Precautions

- Use a reasonable amount of care when using the unit's buttons, sliders, or other controls; and when using its jacks and connectors. Rough handling can lead to malfunctions.
- When connecting / disconnecting all cables, grasp the connector itself—never pull on the cable. This way you will avoid causing shorts, or damage to the cable's internal elements.
- To avoid disturbing your neighbors, try to keep the unit's volume at reasonable levels (especially when it is late at night).
- When you need to transport the unit, pack it in shock-absorbent material. Transporting the unit without doing so can cause it to become scratched or damaged, and could lead to malfunction.

## Handling CD-ROMs

- Avoid touching or scratching the shiny underside (encoded surface) of the disc. Damaged or dirty CD-ROM discs may not be read properly. Keep your discs clean using a commercially available CD cleaner.
- \* Microsoft and Windows are registered trademarks of Microsoft Corporation.
- \* The screen shots in this document are used in compliance with the guidelines of the Microsoft Corporation.
- \* Windows® is known officially as: “Microsoft® Windows® operating system.”
- \* Apple and Macintosh are registered trademarks of Apple Computer, Inc.
- \* Mac OS is a trademark of Apple Computer, Inc.
- \* All product names mentioned in this document are trademarks or registered trademarks of their respective owners.
- \* OMS is a registered trademark of Opcode Systems, Inc.
- \* FreeMIDI is a trademark of Mark of the Unicorn, Inc.

# Contents

|  |           |
|--|-----------|
| <b>Names of Things and What They Do .....</b>  | <b>10</b> |
| Front Panel.....   | 10        |
| Rear Panel.....  | 12        |
| <b>Getting Connected and Installing Drivers (Windows) .....</b>                                      | <b>14</b> |
| Before you install the driver.....   | 14        |
| Installing the Driver .....  | 15        |
| Windows XP/2000 users .....  | 15        |
| Windows Me/98 users.....   | 20        |
| Setting the Driver.....  | 21        |
| Windows XP users.....  | 21        |
| Windows 2000/Me users.....   | 22        |
| Windows 98 users.....  | 23        |
| <b>Getting Connected and Installing Drivers (Macintosh) .....</b>                                    | <b>24</b> |
| Before you install the driver.....   | 24        |
| Driver Installation and Settings.....  | 25        |
| Mac OS X users .....   | 26        |
| Mac OS 9 users.....  | 30        |
| <b>Basic Use .....</b>   | <b>38</b> |
| Basic Connections and MIDI Flow .....  | 38        |
| Transmitting MIDI messages from a MIDI keyboard or digital piano to the sequencer software .....     | 38        |
| Transmitting MIDI Messages from the sequencer software to a MIDI sound module or digital piano ..... | 39        |
| Transmitting MIDI messages from a MIDI Keyboard or other device to a MIDI sound module.....          | 40        |
| <b>Appendices .....</b>  | <b>42</b> |
| Connecting multiple UM-3EX units .....   | 42        |
| Installing the Driver .....  | 43        |
| Connection examples .....  | 44        |
| <b>Troubleshooting .....</b>   | <b>47</b> |
| <b>Main Specifications .....</b>   | <b>56</b> |

## *Deutsch*

---

|   |           |
|---|-----------|
| <b>Name und Funktion der Bedienungselemente .....</b> | <b>58</b> |
|---|-----------|

|   |           |
|---|-----------|
| Vorderseite .....   | 58        |
| Rückseite .....   | 60        |
| <b>Anschlüsse herstellen und Treiber installieren (Windows) .....</b>   | <b>62</b> |
| Vor dem Installieren des Treibers .....                                 | 62        |
| Treiber installieren.....   | 63        |
| Windows XP/2000-Anwender .....  | 63        |
| <b>Anschlüsse herstellen und Treiber installieren (Macintosh) .....</b> | <b>66</b> |
| Vor dem Installieren des Treibers .....                                 | 66        |
| Installation und Einstellungen des Treibers .....                       | 67        |
| Mac OS X-Anwender .....   | 67        |
| <b>Anhang .....</b>   | <b>72</b> |
| Anschluss mehrerer UM-3EX Geräte .....                                  | 72        |

## *Français*

---

|  |           |
|--|-----------|
| <b>Description.....</b>  | <b>74</b> |
| Face avant .....   | 74        |
| Face arrière .....   | 76        |
| <b>Connexion et installation des pilotes (Windows).....</b>    | <b>78</b> |
| Avant d'installer le pilote .....                              | 78        |
| Installation du pilote spécial .....                           | 79        |
| Windows XP/2000 .....  | 79        |
| <b>Connexions et installation des pilotes (Macintosh).....</b> | <b>82</b> |
| Avant d'installer le pilote .....                              | 82        |
| Installation et configuration du pilote .....                  | 83        |
| Utilisateurs de Mac OS X.....                                  | 83        |
| <b>Annexes .....</b>   | <b>88</b> |
| Connexion de plusieurs unités UM-3EX.....                      | 88        |

## *Italiano*

---

|  |           |
|--|-----------|
| <b>Nomi e funzioni degli elementi.....</b> | <b>90</b> |
| Pannello frontale.....                     | 90        |
| Pannello posteriore.....                   | 92        |

|   |            |
|---|------------|
| <b>Collegamento e installazione dei driver (Windows).....</b>   | <b>94</b>  |
| Prima di installare il driver .....                             | 94         |
| Installazione del driver .....                                  | 95         |
| Utenti Windows XP/2000 .....                                    | 95         |
| <b>Collegamento e installazione dei driver (Macintosh).....</b> | <b>98</b>  |
| Prima di installare il driver .....                             | 98         |
| Installazione e configurazione del driver.....                  | 99         |
| Utenti Mac OS X.....  | 99         |
| <b>Appendici .....</b>  | <b>104</b> |
| Collegare più unità UM-3EX.....                                 | 104        |

## *Español*

---

|   |            |
|---|------------|
| <b>Nombres de los diferentes elementos y sus funciones .....</b>    | <b>106</b> |
| Panel frontal .....   | 106        |
| Panel posterior .....   | 108        |
| <b>Conexión e instalación de los controladores (Windows).....</b>   | <b>110</b> |
| Antes de instalar el controlador .....                              | 110        |
| Instalación del controlador.....                                    | 111        |
| Usuarios de Windows XP/2000 .....                                   | 111        |
| <b>Conexión e instalación de los controladores (Macintosh).....</b> | <b>114</b> |
| Antes de instalar el controlador .....                              | 114        |
| Instalación del controlador y ajustes .....                         | 115        |
| Usuarios de Mac OS X .....  | 115        |
| <b>Apéndices .....</b>  | <b>120</b> |
| Conexión de varias unidades UM-3EX .....                            | 120        |
| <b>Index .....</b>  | <b>122</b> |



# Contents of the Package

The UM-3EX includes the following items. When you open the package, first make sure that all items are included. If any are missing, contact the dealer where you purchased the UM-3EX.

## USB MIDI Interface UM-3EX

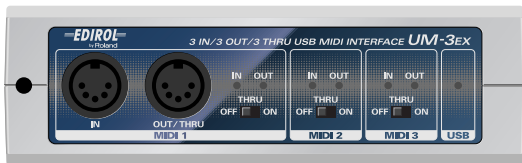

## CD-ROM

This contains drivers for use with the UM-3EX.

## Owner's Manual

This is the manual you are reading. Please keep it on hand for reference.

# Names of Things and What They Do

## Front Panel

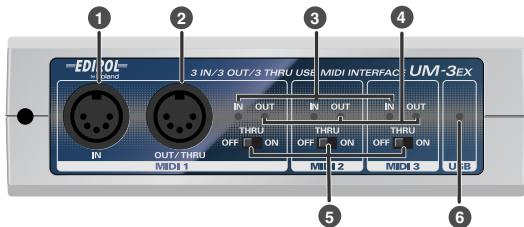

### 1 MIDI IN Connectors

Connect these to the MIDI OUT connectors of the devices (such as a MIDI keyboard) that will be transmitting MIDI messages to your computer.

### 2 MIDI OUT/THRU Connectors

Connect these to the MIDI IN connectors of sound modules or other devices to which you'll be sending MIDI messages from your computer for playback.

### 3 MIDI IN Indicators

If the THRU switch is OFF, this lights when MIDI messages from the device connected to MIDI IN are being received.

### 4 MIDI OUT Indicators

If the THRU switch is OFF, this lights when MIDI messages from the computer are being transmitted.

### 5 THRU Switches

Allow you to select the output destinations of the MIDI messages that arrive from the devices you've connected to the MIDI IN connectors.

## ■ ON/OFF Settings of the THRU Switches

You can use the **THRU switches** to select the transmission destinations for MIDI messages from the devices (MIDI keyboard, digital piano, etc.) connected to the MIDI IN connectors. There is no need to change any cable connections.

|                             |  |
|-----------------------------|--|
| <b>THRU Switch:<br/>OFF</b> | MIDI messages arriving via the corresponding MIDI IN connector are sent to your computer (sequencer software). Normally, you should use this setting.  |
| <b>THRU Switch:<br/>ON</b>  | MIDI messages arriving via the corresponding MIDI IN connector on the UM-3EX are output from the corresponding MIDI OUT/THRU connector of the UM-3EX. Turn this on if you're not using sequencer software. |

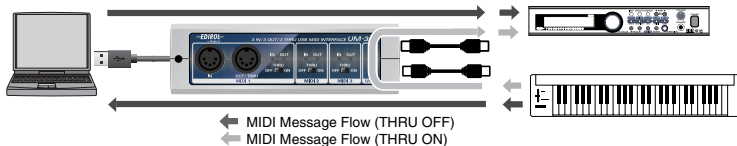

\* Don't change the setting of a **THRU switch** while playback is in progress. Doing so will cause MIDI errors.

## 6 USB Indicator

This will light when you've connected the UM-3EX to your computer and your computer has detected the UM-3EX.

In order for your computer to detect the UM-3EX, you must install the driver and make settings. (→“**Getting Connected and Installing Drivers (Windows)**” (p. 14), “**Getting Connected and Installing Drivers (Macintosh)**” (p. 24))

## Rear Panel

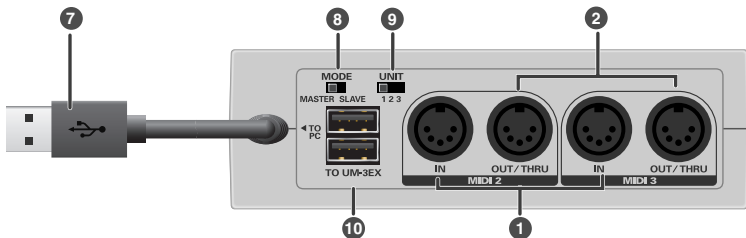

### 7 USB Cable

Connect this to the USB connector of your computer.

### 8 MODE select switch

The UM-3EX can be set to function as either the master or a slave device by means of this switch.

|   |  |
|---|--|
| <b>When using a single UM-3EX unit</b>          | Select the <b>MASTER</b> setting if you're using a single UM-3EX unit.   |
| <b>When multiple UM-3EX units are connected</b> | <ul style="list-style-type: none"><li>• Select the <b>MASTER</b> setting for the UM-3EX that's connected to the computer.</li><li>• Select the <b>SLAVE</b> setting for UM-3EX units that are connected to the UM-3EX connector (p. 13).</li></ul> |

\* Don't change the setting of the MODE select switch while the UM-3EX is connected to your computer. First, you need to disconnect the UM-3EX from your computer. Then, once you've changed the switch setting, you can reconnect it.

\* Connection of multiple units is supported only in Windows XP and Mac OS X. For details, refer to "Connecting multiple UM-3EX units" (p. 42).

## 9 UNIT number select switch

Specifies the **UNIT number** (p. 42) of the UM-3EX.

If you're connecting multiple UM-3EX units, you must set each unit's UNIT number select switch appropriately. Set each UM-3EX to a different UNIT number.

- \* *Don't change the setting of the UNIT number select switch while the UM-3EX is connected to your computer. First, you need to disconnect the UM-3EX from your computer. Then, once you've changed the switch setting, you can reconnect it.*
- \* *Connection of multiple units is supported only in Windows XP and Mac OS X. For details, refer to "**Connecting multiple UM-3EX units**" (p. 42).*

## 10 UM-3EX connectors

Use these when connecting multiple UM-3EX units.

- \* *Do not connect any device other than a UM-3EX to the UM-3EX connector. Doing so may cause the UM-3EX to malfunction.*
- \* *Connection of multiple units is supported only in Windows XP and Mac OS X. For details, refer to "**Connecting multiple UM-3EX units**" (p. 42).*

# Getting Connected and Installing Drivers (Windows)

## Before you install the driver

Here's the procedure for installing a single UM-3EX.

If you're using Windows XP, you can simultaneously connect up to three UM-3EX units to a single computer via USB.

- \* *Connection of multiple units is supported only in Windows XP. For details, refer to "Connecting multiple UM-3EX units" (p. 42).*
- \* *Depending on your system, the second or subsequent unit may not be usable depending on the limitations imposed by the CPU processing speed, hard disk, memory, and the performance of your software.*

### ■ Cautions when connecting

Set the **MODE select switch** and the **UNIT number select switch** before you connect the UM-3EX to your computer.

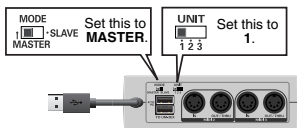

|                                  |                        |
|----------------------------------|------------------------|
| <b>MODE select switch</b>        | Set to <b>MASTER</b> . |
| <b>UNIT number select switch</b> | Set to <b>1</b> .      |

- \* *Don't change the setting of the **MODE select switch** or **UNIT number select switch** while the UM-3EX is connected to your computer. You must first disconnect the UM-3EX from your computer. Then, after you've changed the settings of its switches, you can reconnect it to your computer.*

# Installing the Driver

## What is a driver?

A “**driver**” is software that transfers data between the UM-3EX and application software running on your computer, when your computer and the UM-3EX are connected. The driver sends data from your application to the UM-3EX, and from the UM-3EX to your application.

The installation procedure will differ depending on your system.  
Please proceed to one of the following sections, depending on the system you use.

- Windows XP/2000 users..... p. 15
- Windows Me/98 users ..... p. 20

Steps to be performed on the UM-3EX itself are marked by a **Operation of the UM-3EX** symbol.

## Windows XP/2000 users

1. With the UM-3EX left unconnected, start up Windows.

Do not connect the UM-3EX to the computer until you reach Step 14 ( p. 17).

\* *Disconnect all USB cables except for a USB keyboard and USB mouse (if used).*

\* *Log onto Windows using a user name that has administrative privileges (such as Administrator).*

2. Open the **System Properties** dialog box.

### Windows XP users:

1. Click the Windows **start** menu, and from the menu, select **Control Panel**.

2. In “**Pick a category,**” click “**Performance and Maintenance.**”

3. In “**or pick a Control Panel icon,**” click the **System** icon.

Depending on your setup, the **System** icon may appear directly in the **Control Panel** (Classic view). If so, double-click the **System** icon.

### Windows 2000 users:

1. Click the Windows **Start** menu, and from the menu that appears, select **Settings | Control Panel**.

2. In **Control Panel**, double-click the **System** icon.

3. Click the **Hardware** tab, then click **[Driver Signing]**.  
The **Driver Signing Options** dialog box will open.
4. In the **Driver Signing Options** dialog box, select **“Ignore,”** then click **[OK]**.  
If the current setting is **“Warn”** or **“Block,”** change this to **“Ignore.”** Then, when you’ve finished installing the driver, change it back to the original setting.
5. Click **[OK]** to close the **System Properties** dialog box.
6. Exit all currently running software (applications).  
Also close any currently open windows. If you are using virus checking or similar software, you must exit all of these programs as well.
7. Prepare the CD-ROM.  
Insert the CD-ROM into your computer’s CD-ROM drive.  
*\* If the message **“Windows can perform the same action each time you insert a disk or connect a device with this kind of file”** appears, **[Cancel]**.*
8. From the Windows **start** menu, choose **Run...**
9. In the **Open** field of the **Run...** dialog box, type the following and click **[OK]**.  
**D: \Driver\XP2k\Setup.exe**  
*\* The drive name is **D:** in the example shown here, but may be different on your system. Use the drive name for your CD-ROM drive.*
10. The **Driver Setup** dialog box will appear.  
Click **[Next]**.
11. To begin the installation, click **[Next]** once again. Installation will begin.

#### **Windows XP users:**

If **“Driver Signing Options”** in step 4 is set to anything other than **“Ignore,”** a dialog box with an **“I”** or **“x”** symbol will appear. If a **[Continue Anyway]** button is displayed, click **[Continue Anyway]** to proceed with the installation. If you are unable to continue, click **[OK]** and repeat the driver installation from step 1.

#### **Windows 2000 users:**

If **“Driver Signing Options”** in step 4 is set to anything other than **“Ignore,”** a dialog box indicating **“Digital Signature Not Found”** will appear. If a **[Yes]** button is displayed, click **[Yes]** to proceed with the installation. If you are unable to continue, click **[OK]** and repeat the driver installation from step 1.

The **“Setup is now ready to install the drivers”** dialog box will appear.



**12.** **Operation of the UM-3EX** Set the UM-3EX's **MODE select switch** to **MASTER**.

**13.** **Operation of the UM-3EX** Set the UM-3EX's **UNIT number select switch** to **1**.

**14.** **Operation of the UM-3EX** Connect only one UM-3EX to your computer.

A message of **"Found New Hardware"** will appear. Please wait.

\* *This unit is equipped with a protection circuit. A brief interval (a few seconds) after connecting the UM-3EX is required before the unit will operate normally.*

#### **Windows XP users:**

**1.** The **Found New Hardware Wizard** dialog box will appear.

If the message **"Connect to Windows Update to search for software?"** appears, choose **"No"** and then click **[Next]**.

**2.** Make sure that **"EDIROL UM-3"** is indicated. Then, choose **"Install the software automatically (Recommended)"** and click **[Next]**.

\* *If **"Driver Signing Options"** in step 4 is set to anything other than **"Ignore,"** a dialog box with an **"I"** symbol will appear. Click **[Continue Anyway]** to proceed with the installation.*

#### **Windows 2000 users:**

If **"Driver Signing Options"** in step 4 is set to anything other than **"Ignore,"** a dialog box indicating **"Digital Signature Not Found"** will appear. Click **[Yes]** to proceed with the installation.

**15.** The **Completing the Found New Hardware Wizard** dialog box will appear.

Click **[Finish]**.

**16.** In the **Driver Setup** dialog box, click **[Close]**.

If the **Change System Settings** dialog box appears, click **[Yes]**. Windows will restart automatically.

\* *If you changed the **"Driver Signing Options"** setting in step 4, restore the original settings after Windows has restarted.*

This completes driver installation.

Next, in order to ensure that MIDI processing occurs smoothly, you need to make settings so that Background Services is given priority.

(→ **"Giving priority to Background Services"** (p. 18))

## ■ Giving priority to Background Services

To ensure that MIDI data is handled smoothly, proceed as follows to make this setting.

### Windows XP users:

1. Open the **System Properties** dialog box.
    1. From the Windows **start** menu, choose **Control Panel**.
    2. In “**Pick a category**,” click **Performance and Maintenance**.
    3. In “**or Pick a Control Panel icon**,” click the **System** icon.  
Depending on your setup, the **System** icon may appear directly in the Control Panel (Classic view). If so, double-click the **System** icon.
  2. Click the **Advanced** tab.
  3. In the right side of the **Performance** area, click **[Settings]**.  
The **Performance Options** dialog box will open.
  4. Click the **Advanced** tab.
  5. In the **Processor scheduling** area, choose “**Background services**,” and click **[OK]**.
- 
6. In the **System Properties** dialog box, click **[OK]**.  
The **System Properties** dialog box will close.  
Next, you’ll make the driver settings. (→ “**Setting the Driver**” (p. 21))

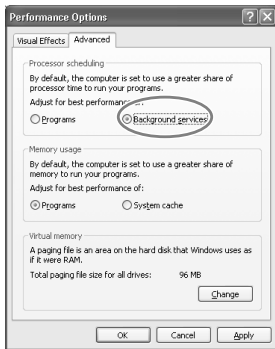

### Windows 2000 users:

1. Click the Windows **Start** button, and from the menu that appears, select **Settings | Control Panel**.
2. In **Control Panel**, double-click the **System** icon.
3. Click the **Advanced** tab.
4. At the right of the **Performance** field, click **[Performance Options]**.  
The **Performance Options** dialog box will appear.
5. In the **Application response** field, choose **“Background services”** and click **[OK]**.

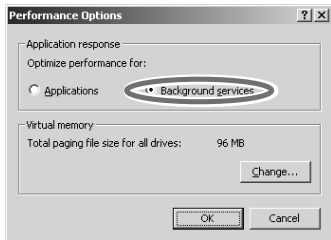

6. Click **[OK]** to close the **System Properties** dialog box.  
The **System Properties** dialog box will close.  
Next, you'll make the driver settings. (→ **“Setting the Driver”** (p. 21))

## Windows Me/98 users

1. With the UM-3EX left unconnected, start up Windows.  
Do not connect the UM-3EX to the computer until you reach Step 10.
2. Exit all currently running software.  
Also close any open windows. If you are using virus checking or similar software, be sure to exit it as well.
3. Prepare the CD-ROM.  
Insert the CD-ROM into the CD-ROM drive of your computer.
4. Click the Windows **Start** menu. From the menu that appears, select **Run...**  
The **Run...** dialog box will appear.
5. In the **Run** dialog box that appears, input the following into the **Open** field, and click **[OK]**.  
**D:\Driver\Me98\Setup.exe**  
*\* The drive name is **D:** in the example shown here, but may be different on your system. Use the drive name for your CD-ROM drive.*
6. The **Driver Setup** dialog box will appear.  
Click **[Next]**.
7. To begin the installation, click **[Next]** once again. Installation will begin.  
The **“Setup is now ready to install the drivers”** dialog box will appear.  
Now you are ready to install the driver.
8. **Operation of the UM-3EX** Set the UM-3EX's **MODE select switch** to **MASTER**.
9. **Operation of the UM-3EX** Set the UM-3EX's **UNIT number select switch** to **1**.
10. **Operation of the UM-3EX** Connect the UM-3EX to your computer.  
A message of **“Found New Hardware”** will appear. Please wait.  
*\* This unit is equipped with a protection circuit. A brief interval (a few seconds) after connecting the UM-3EX is required before the unit will operate normally.*
11. In the **Driver Setup** dialog box, click **[Close]**.  
Next, you'll make the driver settings. (→**“Setting the Driver”** (p. 21))

# Setting the Driver

The following describes the settings needed to use the UM-3EX with Media Player or other sequencer software using Windows standard device settings.

If you are using sequencer software that does not utilize Windows standard device settings, make the device settings within the sequencer software.

## Windows XP users

1. Open the **Sounds and Audio Devices Properties** dialog box.
  1. From the Windows **start** menu, choose **Control Panel**.
  2. In “**Pick a category,**” click **Sound, Speech, and Audio Devices**.
  3. In “**or Pick a Control Panel icon,**” click the **Sounds and Audio Devices** icon.  
Depending on your setup, the **Sounds and Audio Devices** icon may appear directly in the **Control Panel** (Classic view). If so, double-click the **Sounds and Audio Devices** icon.
2. Click the **Audio** tab.

3. For **MIDI music playback**, click the ▼ located at the right of [**Default device**], and select the MIDI device from the list that appears.

If you select “**1: EDIROL UM-3 MIDI 1,**” a sound module connected to the UM-3EX’s MIDI 1 OUT/THRU connector can be played from sequencer software (such as Media Player) that uses Windows standard device settings.

*\* The number “1:” at the beginning of the device name is the unit number of the UM-3EX. This value will depend on the setting of the UNIT number select switch.*

4. Close the **Sounds and Audio Devices** Properties dialog box. Click [**OK**] to complete the settings.

This completes the driver settings.

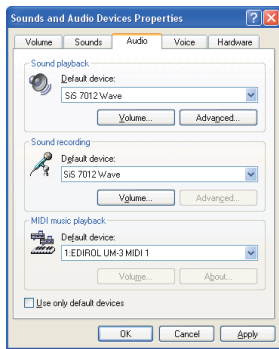

## Windows 2000/Me users

1. Open the **Sounds and Multimedia Properties** dialog box.
  1. Click the Windows **start** button, and from the menu that appears, select **Settings | Control Panel**.
  2. In **Control Panel**, double-click the **Sounds and Multimedia** icon.  
If **Sounds and Multimedia** icon is not displayed, click “**Show all control panel options**” in the frame at the left.
2. Click the **Audio** tab.
3. Click ▼ in the **MIDI Music Playback [Preferred device]** menu and select the MIDI device from the list that appears.  
If you select “**EDIROL UM-3 MIDI 1**,” a sound module connected to the UM-3EX’s MIDI 1 OUT/THRU connector can be played from sequencer software (such as Media Player) that uses Windows standard device settings.
4. Close the **Sounds and Multimedia Properties** dialog box.  
Click **[OK]** to complete the settings.

This completes the driver settings.

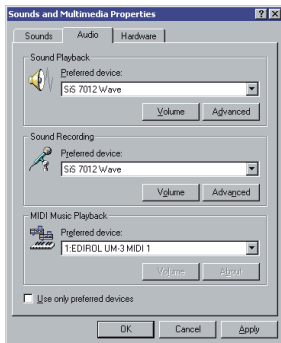

## Windows 98 users

1. Open the **Multimedia Properties** dialog box.
  1. Click the Windows **Start** menu, and from the menu that appears, select **Settings | Control Panel**.
  2. In **Control Panel**, double-click the **Multimedia** icon.
2. Click the **MIDI** tab.
3. Select **[Single instrument]**, and select the MIDI device from the list that appears.

If you select “**EDIROL UM-3 MIDI 1**,” a sound module connected to the UM-3EX’s MIDI 1 OUT/THRU connector can be played from sequencer software (such as Media Player) that uses Windows standard device settings.

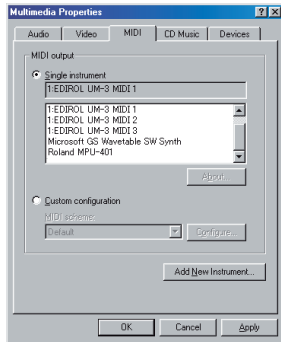

4. Close the **Multimedia Properties** dialog box.  
Click **[OK]** to complete the settings.

This completes the driver settings.

# Getting Connected and Installing Drivers (Macintosh)

## Before you install the driver

Here's the procedure for installing a single UM-3EX.

If you're using Mac OS X, you can simultaneously connect up to three UM-3EX units to a single Macintosh via USB.

- \* *Connection of multiple units is supported only in Mac OS X. For details, refer to "Connecting multiple UM-3EX units" (p. 42).*
- \* *Depending on your system, the second or subsequent unit may not be usable depending on the limitations imposed by the CPU processing speed, hard disk, memory, and the performance of your software.*

### ■ Cautions when connecting

Set the **MODE select switch** and the **UNIT number select switch** before you connect the UM-3EX to your Macintosh.

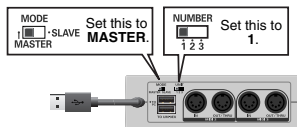

|                                  |                        |
|----------------------------------|------------------------|
| <b>MODE select switch</b>        | Set to <b>MASTER</b> . |
| <b>UNIT number select switch</b> | Set to <b>1</b> .      |

- \* *Don't change the setting of the **MODE select switch** or **UNIT number select switch** while the UM-3EX is connected to your computer. You must first disconnect the UM-3EX from your Macintosh. Then, after you've changed the settings of its switches, you can reconnect it to your Macintosh.*



# Driver Installation and Settings

## What is a driver?

A “**driver**” is software that transfers data between the UM-3EX and application software running on your Macintosh, when your Macintosh and the UM-3EX are connected. The driver sends data from your application to the UM-3EX, and from the UM-3EX to your application.

The installation procedure will differ depending on your system.

Please proceed to one of the following sections, depending on the system you use.

- Mac OS X users ..... p. 26
- Mac OS 9 users..... p. 30

Steps to be performed on the UM-3EX itself are marked by a **Operation of the UM-3EX** symbol.

## Mac OS X users

### ■ Installing the driver

- \* If the **“Authenticate”** dialog box appears during the installation, input the password and click **“OK.”**
- \* What you actually see on your Macintosh screen may be different, depending on your computing environment and the operating system you're using.

1. With the UM-3EX left unconnected, start up Macintosh.
  - \* Disconnect all USB cables other than those for your keyboard and mouse, and restart your Macintosh.
2. Exit all currently running software (applications).
3. Prepare the CD-ROM.  
Insert the CD-ROM into the CD-ROM drive of your Macintosh.
4. In the **Driver (Mac OS X)** folder of the CD-ROM, double-click **UM3USBDriver.pkg**.  
A message such as **“This Installer package needs to...”** may appear.  
Click **“Continue.”**
5. The display will indicate **“Welcome to the EDIROL UM-3Driver Installer.”**  
Click **[Continue]**.
6. The display will indicate **“Select a Destination.”**  
Click the drive in which the operating system is installed to select it, and then click **[Continue]**.
  - \* Select your startup disk as the drive.
7. The display will indicate **“Easy Install.”**  
Click **[Install]** or **[Upgrade]**.
8. The display will indicate **“Installing this software requires you to restart your computer when the installation is done.”**  
Click **[Continue Installation]**.
9. The display will indicate **“The software was successfully installed.”**  
Click **[Restart]** to restart your Macintosh.

This completes installation of the UM-3EX driver.

Next, make MIDI device settings. (→ **“Setting the driver”** (p. 27))

## ■ Setting the driver

The following describes the settings enabling use of the UM-3EX with sequencer software using Macintosh standard device settings.

If you are using sequencer software that does not utilize Macintosh standard device settings, make the device settings within the sequencer software.

\* *What you actually see on your Macintosh screen may be different, depending on your computing environment and the operating system you're using.*

**1.** **Operation of the UM-3EX** Set the UM-3EX's **MODE select switch** to **MASTER**.

**2.** **Operation of the UM-3EX** Set the UM-3EX's **UNIT number select switch** to **1**.

**3.** **Operation of the UM-3EX** Connect only one UM-3EX to your Macintosh.

\* *Connect the cable to the USB connector of the Macintosh itself, not to the USB connector of the keyboard.*

\* *This unit is equipped with a protection circuit. A brief interval (a few seconds) after connecting the UM-3EX is required before the unit will operate normally.*

**4.** Open the **Applications** folder of your Macintosh hard disk. In the **Utilities** folder, double-click **Audio MIDI Setup** to open the **Audio MIDI Setup** dialog box.



**5.** Click the **MIDI Devices** tab.

**6.** Confirm that **1: UM-3** appears in the **Audio MIDI Setup** dialog box.

\* *The number "1:" at the beginning of the device name is the unit number of the UM-3EX. This value will depend on the setting of the UNIT number select switch.*

\* *If "1: UM-3" does not appear or if it is grayed out, it means that the UM-3EX is not being recognized properly. Click **Rescan MIDI**. Also try disconnecting and reconnecting the UM-3EX.*

\* *Previous settings from installation of a different version of the driver may still remain. If this is the case, click on the grayed "1: UM-3" to select it, then click **Remove Selected Device** to delete the settings.*

**7.** Click **Add Device** three times.

Three **new external device** will appear.

8. Specify the **device name** for each **new external device**.
  1. Click the **new external device** you added, and then click **Show Info**.
  2. Enter the name in the **Device Name** field.

|                               |           |
|-------------------------------|-----------|
| <b>First external device</b>  | 1: UM-3 1 |
| <b>Second external device</b> | 1: UM-3 2 |
| <b>Third external device</b>  | 1: UM-3 3 |

\* Enter the **UNIT** number of the UM-3EX as the first number "1:."



9. Use the mouse to drag the ▼ and ▲ symbols that indicate the inputs and outputs of the **1: UM-3 icon** and the **new external device** icons so that they are connected as follows.

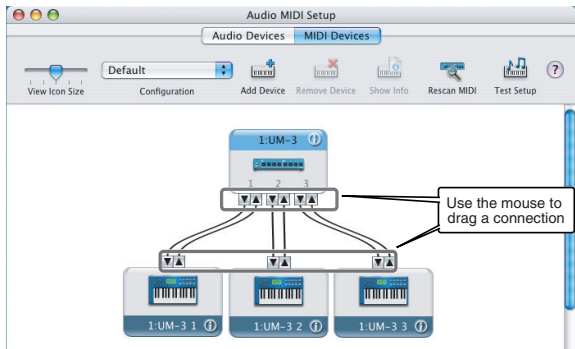

**10. If running Mac OS X v10.2:**

Close the **Audio MIDI Setup** dialog box. The settings are completed.

**If running Mac OS X v10.3 or later:**

Confirm that MIDI is being transmitted and received correctly. Perform Steps 11–14 (p. 29).

## 11. Click **Test Setup**.

The shape of the mouse cursor changes .

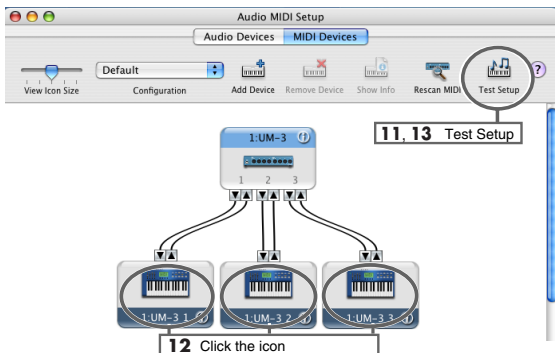

12. Click the area shown in the illustration. If the corresponding MIDI OUT indicator of the UM-3EX blinks, the settings are correct.

13. Click **Test Setup** and complete the confirmation.

14. Close the **Audio MIDI Setup** dialog box.

### **When using the UM-3EX with your sequencer software**

Before using the UM-3EX with your sequencer software, please note the following points.

- Connect the UM-3EX to your Macintosh before you start up your sequencer software.
- Do not disconnect the UM-3EX from your Macintosh while your sequencer software is running. Quit your sequencer software before you disconnect the UM-3EX from your Macintosh.
- The UM-3EX will not operate in the Mac OS X Classic environment. Use the UM-3EX when the Classic environment is not running.

## Mac OS 9 users

### ■ Installing the UM-3 driver

#### **Use either OMS or FreeMIDI as the MIDI driver.**

The included **UM-3 driver** is an add-on module for using the UM-3EX with OMS or FreeMIDI. OMS can be found in the **OMS 2.3.8 E** folder within the **OMS (Mac OS 9)** folder of the CD-ROM. If you would like to know more about OMS, refer to **OMS\_2.3\_Mac.pdf** which can be found in the same folder.

- \* Either **OMS** or **FreeMIDI** must be installed in your Macintosh, as appropriate for the sequencer software you are using.
- \* If you install OMS after installing the UM-3 driver, you must install the UM-3 driver once again.

If a UM-3EX is already connected to your Macintosh when you install the driver, a message like the following will appear when the Macintosh is started up. Perform the steps described below as appropriate for the message that is displayed.

If the screen indicates:

**“Software needed for the USB device “UM-3” is not available. Would you like to look for the software on the Internet?”** → click **[Cancel]**.

1. With the UM-3EX left unconnected, start up Macintosh.
  - \* *Disconnect all USB cables other than those for your keyboard and mouse, and restart your Macintosh.*
2. Exit all currently running software (applications).
3. Prepare the CD-ROM. Insert the CD-ROM into the CD-ROM drive of your Macintosh.
4. Double-click the **UM-3 Driver-E Installer** icon (found in the **Driver E (Mac OS 9)** folder of the CD-ROM) to start up the installer.
5. Verify the **Install Location**, and click **[Install]**.

The installation location will be shown differently depending on your system. Make sure that you have selected the startup disk for the system you are currently using.

6. If a message like the following is displayed, click **[Continue]**.  
The other currently running software will exit, and installation will continue.

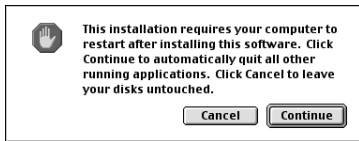

7. A dialog box will indicate **Installation was successful**.  
Click **[Restart]** to restart your Macintosh.

Next, make the driver settings.

- OMS users..... p. 32
- FreeMIDI users ..... p. 36

## ■ OMS settings

If you are using FreeMIDI, proceed to “FreeMIDI settings” (p. 36).

1. **Operation of the UM-3EX** Set the UM-3EX's **MODE select switch** to **MASTER**.

2. **Operation of the UM-3EX** Set the UM-3EX's **UNIT number select switch** to **1**.

3. **Operation of the UM-3EX** Connect only one UM-3EX to your Macintosh.

\* *Connect the cable to the USB connector of the Macintosh itself, not to the USB connector of the keyboard.*

\* *This unit is equipped with a protection circuit. A brief interval (a few seconds) after connecting the UM-3EX is required before the unit will operate normally.*

4. From the CD-ROM, drag the **Driver E (Mac OS 9) - OMS Setting** folder into the **Opcode - OMS Applications** folder on the hard disk of your Macintosh to copy it there.



OMS Setting

5. In the **Opcode - OMS Applications** folder where you installed **OMS**, double-click **OMS Setup** to start it up.



OMS Setup

6. If a dialog box like the one shown here appears, click **[Turn It Off]**. A confirmation dialog box will then appear, so click **[OK]**.

\* *We recommend that you turn off **AppleTalk**, by selecting **Chooser** from the **Apple** menu.*

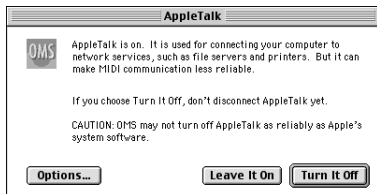



7. The **Create a New Studio Setup** dialog box will appear. Click **[Cancel]**.  
If you accidentally clicked **[OK]**, click **[Cancel]** in the next screen.

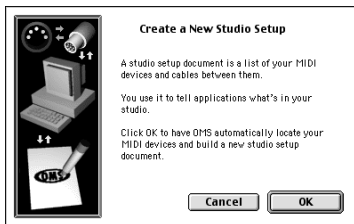

8. Choose **Open** from the **File** menu.  
From the **OMS Setting** folder that you copied in step 4, select the **UM-3** file, and click **[Open]**.  
A screen like the one shown here will appear.

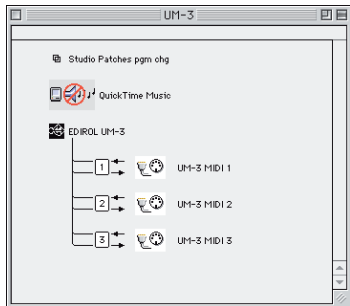

9. From the **Edit** menu, select **OMS MIDI Setup**.  
In the **OMS MIDI Setup** dialog box that appears, check **Run MIDI in background**, and click **[OK]**.

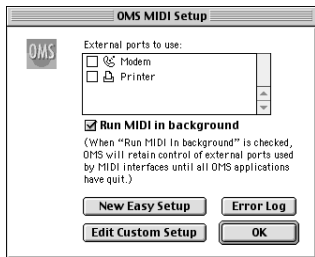

10. From the **File** menu, choose **Make Current**.  
If you are unable to select **Make Current**, it has already been applied, and you may continue to the next step.

A diamond mark (<) indicates the settings are enabled.

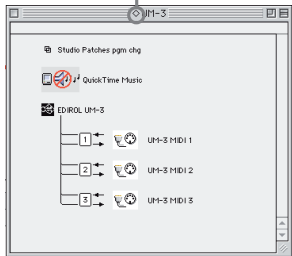

11. Verify that MIDI transmission and reception can be performed correctly.  
From the **Studio** menu, choose **Test Studio**.

12. When you move the mouse cursor near the MIDI connector icon, the cursor will change to a  shape. Click the MIDI connector icon shown in the illustration. If the corresponding MIDI OUT indicator of the UM-3EX blinks, the settings are correct.

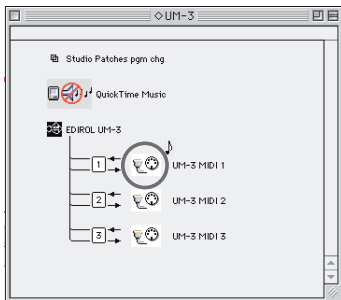

13. Exit OMS Setup.

From the **File** menu, choose **Exit**. If the **AppleTalk** confirmation dialog box appears, click **[OK]** to close the dialog box.

## ■ FreeMIDI settings

1. **Operation of the UM-3EX** Set the UM-3EX's **MODE select switch** to **MASTER**.
2. **Operation of the UM-3EX** Set the UM-3EX's **UNIT number select switch** to 1.
3. **Operation of the UM-3EX** Connect only one UM-3EX to your Macintosh.

\* *Connect the cable to the USB connector of the Macintosh itself, not to the USB connector of the keyboard.*

\* *This unit is equipped with a protection circuit. A brief interval (a few seconds) after connecting the UM-3EX is required before the unit will operate normally.*

4. From the CD-ROM, drag the **Driver E (Mac OS 9) - FreeMIDI Setting** folder into the **FreeMIDI Applications** folder on the hard disk of your Macintosh to copy it there.
5. Open the **FreeMIDI Applications** folder from the location into which you installed FreeMIDI, and double-click the **FreeMIDI Setup** icon to start it up.  
When "OMS is installed on this computer..." appears, click [**FreeMIDI**].
6. The first time you start up, use the following procedure.
  1. A dialog box saying "Welcome to FreeMIDI!" will appear.  
Click [**Continue**].
  2. The **FreeMIDI Preferences** dialog box will appear.  
Click [**Cancel**].
  3. The **About Quick Setup** dialog box will appear.  
Click [**Cancel**].
7. From the **File** menu, choose **Open**.  
If you are unable to select **Open**, return to step 5 and continue the procedure.
  1. From the **File** menu, choose **FreeMIDI Preference**.
  2. Uncheck "Use OMS when available."
  3. Close **FreeMIDI**.
8. Select **UM-3** from the **FreeMIDI Setting** folder you copied in step 4, and click [**Open**].
9. Verify that MIDI transmission and reception occur correctly.  
From the **MIDI** menu, choose **Check Connections**.

10. The mouse cursor will change to the shape of a keyboard.

Click the icon shown in the illustration. If the corresponding MIDI OUT indicator of the UM-3EX blinks, the settings are correct.

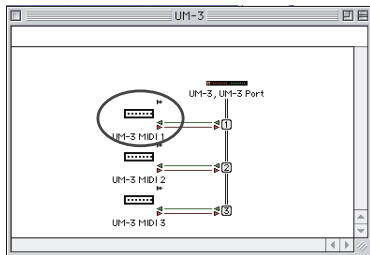

11. Once again choose the **MIDI** menu command **Check Connections** to end the test.

12. From the **File** menu, choose **Quit** to exit **FreeMIDI Setup**.

# Basic Use

This chapter describes different basic methods of connecting the UM-3EX according to how the UM-3EX is to be used.

## Basic Connections and MIDI Flow

### Transmitting MIDI messages from a MIDI keyboard or digital piano to the sequencer software

To transmit MIDI messages from a MIDI keyboard or digital piano to the sequencer software or make a MIDI recording of a keyboard performance or other performance using sequencer software on your computer, make the following connections and settings.

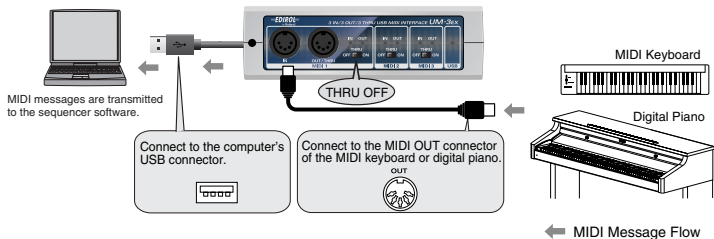

#### MIDI device setting

In your sequencer software, select the MIDI device that corresponds to the connector to which you connected your MIDI keyboard or digital piano etc.

#### THRU switch setting

Turn the **THRU** switch off.

MIDI messages from the MIDI device (e.g. MIDI keyboard, digital piano) connected to the UM-3EX's MIDI IN connector are transmitted to the computer.

\* Don't change the setting of the **THRU** switch while you're using the UM-3EX. Doing so will cause MIDI errors.

## Transmitting MIDI Messages from the sequencer software to a MIDI sound module or digital piano

If transmitting MIDI messages from the sequencer software to a MIDI sound module or digital piano, or if using a MIDI sound module's or digital piano's sound generator to play the sounds from the playback of sequencer software on the computer, make the following connections and settings.

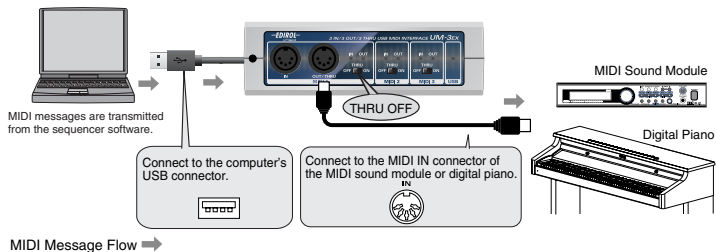

### MIDI device setting

In your sequencer software, select the MIDI device that corresponds to the connector to which you connected your MIDI keyboard or digital piano etc.

- \* For details on settings for sequencer software that uses Windows standard device settings, refer to **"Setting the Driver"** (p. 21).

### THRU switch setting

Turn the **THRU switch off**.

MIDI messages from the computer are transmitted to the MIDI device (e.g., MIDI sound module, digital piano) connected to the UM-3EX's MIDI OUT/THRU connector.

- \* Don't change the setting of the **THRU switch** while you're using the UM-3EX. Doing so will cause MIDI errors.

## Transmitting MIDI messages from a MIDI Keyboard or other device to a MIDI sound module

If you want to play a MIDI keyboard and send MIDI messages to a MIDI sound module, make the connections and settings shown below.

There is no need to connect the UM-3EX to a computer.

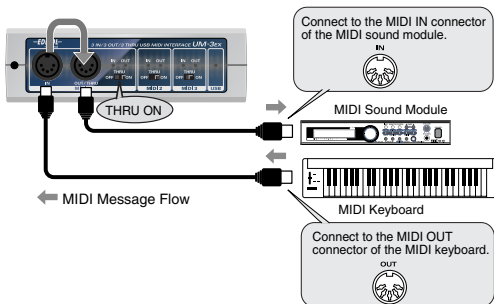

### MIDI device setting

Since no computer is used, there is no need to make MIDI device settings.

### THRU switch setting

Turn the **THRU** switch on.

MIDI messages from the MIDI keyboard or digital piano connected to the UM-3EX's MIDI IN connector will be sent to the MIDI sound module connected to the UM-3EX's MIDI OUT/THRU connector. Even if the UM-3EX is connected to a computer, no MIDI messages will be sent to the computer.

\* Don't change the setting of a **THRU switch** while playback is in progress. Doing so will cause MIDI errors.



## ■ ON/OFF Settings of the THRU Switches

You can use the **THRU switches** to select the transmission destinations for MIDI messages from the devices (MIDI keyboard, digital piano, etc.) connected to the MIDI IN connectors. There is no need to change any cable connections.

| Switch Setting | MIDI Message Destination Device  |
|----------------|--|
| OFF            | MIDI messages are transmitted to your computer (sequencer software).   |
| ON             | MIDI messages are transmitted to the MIDI devices (e.g., MIDI sound module) connected to the MIDI OUT/THRU connectors. |

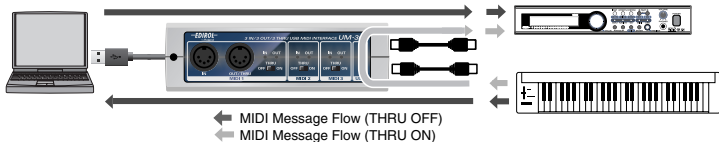

\* Don't change the setting of a **THRU switch** while playback is in progress. Doing so will cause MIDI errors.

# Appendices

## Connecting multiple UM-3EX units

If you're using Windows XP or Mac OS X, you can simultaneously connect up to three UM-3EX units via USB to a single computer. Depending on your system, the second or subsequent unit may not be usable depending on the limitations imposed by the CPU processing speed, hard disk, memory, and the performance of your software.

\* *Connection of multiple units is supported only in Windows XP and Mac OS X.*

### ■ UNIT number

If you're connecting multiple UM-3EX units, you must set each unit's UNIT number select switch appropriately. Set each UM-3EX to a different UNIT number.

The UNIT number is shown as "1:" or "2:" etc. at the beginning of the MIDI device name.

The value of the "1:" or "2:" indication will depend on the setting of the UNIT number select switch.

Install the driver as described in "**Installing the Driver**" (p. 43).

The separately available RAF-70 rack mount adaptor lets you mount up to three units side by side in a EIA-1U rack.

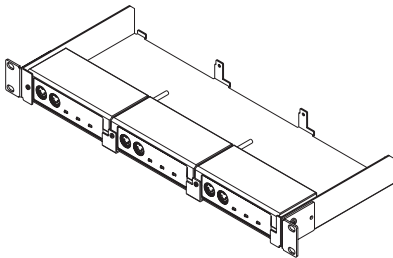

## Installing the Driver

\* If you are using Windows XP, log on as a user that has administrative privileges (e.g., Administrator).

1. As described in **Getting Connected and Installing Drivers (Windows)** (p. 14) and **Getting Connected and Installing Drivers (Macintosh)** (p. 24), install only one unit.

\* Do not connect the second and third UM-3EX units.

2. Temporarily disconnect the first UM-3EX unit from the computer.
3. Connect and make settings for the second and third UM-3EX units.
  1. On the second and third UM-3EX units, set the **MODE select switch** to **SLAVE**.
  2. On the second and third UM-3EX units, set the **UNIT number select switch** to **2 or 3**.
  3. Connect the second and third UM-3EX units to the **UM-3EX connector** of the first unit.
4. Connect the first UM-3EX unit to the computer.

### Windows XP users:

5. The **Found New Hardware Wizard** dialog box will appear.  
If the message “**Connect to Windows Update to search for software?**” appears, choose “**No**” and then click [**Next**].
6. Choose “**Search for the best driver in these locations**” and click [**Next**].  
If a dialog box with an “**I**” or “**x**” symbol will appear, click [**Continue Anyway**] to proceed with the installation. If you are unable to continue, click [**OK**] and make “**Driver Signing Options**” (p. 16), repeat step 4.
7. The **Completing the Found New Hardware Wizard** dialog box will appear.  
Click [**Finish**].
8. If the **Found New Hardware Wizard** dialog box appears again, repeat steps 5–8.

This completes driver installation.

### Mac OS X users:

This completes driver installation.

Make driver settings for the second and third UM-3EX units as described in “**Setting the driver**” (p. 27).

## Connection examples

### ■ Connecting two UM-3EX units

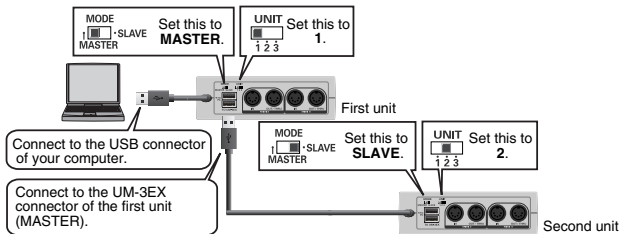

### MODE select switch and UNIT number select switch settings

|                                  |  |
|----------------------------------|--|
| <b>MODE select switch</b>        | <ul style="list-style-type: none"><li>• Select the <b>MASTER</b> setting for the UM-3EX that's connected to the computer.</li><li>• Select the <b>SLAVE</b> setting for UM-3EX unit that is connected to the UM-3EX connector.</li></ul> |
| <b>UNIT number select switch</b> | <ul style="list-style-type: none"><li>• Set the first unit to <b>1</b>.</li><li>• Set the second unit to <b>2</b>.</li></ul>   |

\* Don't change the setting of the **MODE select switch** or **UNIT number select switch** while the UM-3EX is connected to your computer. You must first disconnect the UM-3EX from your computer. Then, after you've changed the settings of its switches, you can reconnect it to your computer.

## ■ Connecting three UM-3EX units

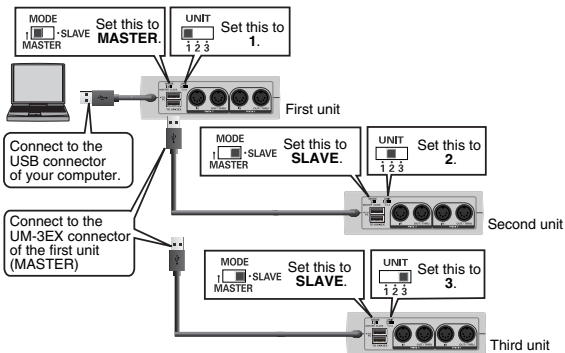

### MODE select switch and UNIT number select switch settings

|                                  |  |
|----------------------------------|--|
| <b>MODE select switch</b>        | <ul style="list-style-type: none"><li>• Select the <b>MASTER</b> setting for the UM-3EX that's connected to the computer.</li><li>• Select the <b>SLAVE</b> setting for UM-3EX units that are connected to the UM-3EX connector.</li></ul> |
| <b>UNIT number select switch</b> | <ul style="list-style-type: none"><li>• Set the first unit to <b>1</b>.</li><li>• Set the second unit to <b>2</b>.</li><li>• Set the third unit to <b>3</b>.</li></ul>   |

\* Don't change the setting of the **MODE select switch** or **UNIT number select switch** while the UM-3EX is connected to your computer. You must first disconnect the UM-3EX from your computer. Then, after you've changed the settings of its switches, you can reconnect it to your computer.

Don't make connections like the following.

### UM-3EX set to SLAVE and connected to a computer



### UM-3EX set to MASTER and connected to a UM-3EX connector

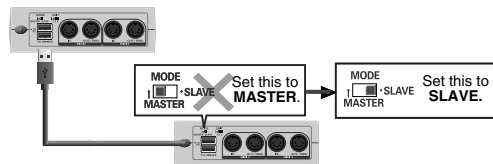

# Troubleshooting

If you experience problems, read this chapter first. It contains tips for solving most problems.

\* For details on operating your Windows or Macintosh computer, refer to the owner's manual of the computer and operating system you are using.

## Problems Related to the USB Driver

### Cannot install the driver correctly

Install the UM-3EX driver once again as described in “**Getting Connected and Installing Drivers (Windows)**” (p. 14) or “**Getting Connected and Installing Drivers (Macintosh)**” (p. 24).

#### **Is the UM-3EX connected correctly?**

Make sure that the USB connector of your computer is connected to the UM-3EX.

#### **Could any other USB device be connected?**

Before you install, disconnect all USB devices except for your mouse and keyboard.

#### **Could other software or resident software (such as antivirus programs) be running?**

Installation may not be successful if other programs are running.

Be sure to close all other programs before installation.

#### **Is the CD-ROM correctly inserted into your CD-ROM drive?**

Installation is not possible unless the CD-ROM included with the UM-3EX is inserted in your CD-ROM drive. Make sure that the CD-ROM is correctly inserted into your CD-ROM drive.

#### **Are you attempting to install from a networked CD-ROM drive?**

You cannot install from a networked CD-ROM drive.

#### **Is the CD-ROM or the lens of the CD-ROM drive dirty?**

If the CD-ROM or the lens of the CD-ROM drive is dirty, the installer may not work correctly.

Clean the disc and/or lens using a commercially-available CD cleaner or lens cleaner.

**Is your computer's power-conservation mode turned off?**

If power-conservation settings are enabled on your computer, please disable any such settings. For the procedure, refer to the owner's manual of your computer.

**Is there sufficient free space on your hard disk?**

Delete unneeded files to increase the amount of free space. After deleting the unneeded files, empty the recycling bin.

**Does your computer or USB hub have sufficient power supply capacity?**

The UM-3EX cannot be connected if insufficient power is supplied to it. Check whether one of the following cases apply.

- If you are using the UM-3EX with a notebook computer that is running on its battery, operation may be unreliable with some models of computer. If this is the case, connect the AC adaptor to your notebook computer.
- The power conservation mode of your computer may limit the power that is supplied to USB. Check the settings of your computer.
- In some cases, the UM-3EX cannot be used with a bus-powered hub (a hub that does not contain a power supply). Please use a self-powered hub (a hub that contains a power supply).

**Is USB enabled on your computer?**

Refer to the operation manual for your computer, and make sure that USB is enabled.

**Does your computer meet the USB specifications?**

If you are using a computer that does not fulfill the electrical requirements of the USB specifications, operation may be unstable. In this case, you may be able to solve the problem by connecting a USB hub.

**In the Device Manager, do you see "Other device," "Unknown device," or a device for which "?", "!" or "x" is displayed? (Windows)**

If the driver installation could not be successfully completed, the installed driver may remain in an incomplete state.

Re-install the driver. (→"Installing the Driver" (p. 15))

**Is OMS or FreeMIDI installed? (Mac OS 9)**

The UM-3 driver cannot be installed unless OMS or FreeMIDI are installed. Please install OMS or FreeMIDI.



## You are asked to install the driver file even though you installed the driver (Windows)

**Could the MODE select switch of the UM-3EX that's connected to your computer be set to SLAVE?**

Set the UM-3EX's MODE select switch to MASTER, and reconnect it.

**Did you connect the UM-3EX to a different USB connector than the one you used when installing the driver?**

If your computer or USB hub has two or more USB connectors, and you connect the UM-3EX to a different USB connector, you may be asked for the driver file even though the driver has already been installed in your computer. (Such a response does not indicate a malfunction.) Proceed as follows to install the driver.

1. Connect the UM-3EX to your computer.

**Windows XP users:**

1. The **Found New Hardware Wizard** dialog box will appear.  
If the message **"Connect to Windows Update to search for software?"** appears, choose **"No"** and then click **[Next]**.
2. Choose **"Install the software automatically (Recommended)"** and click **[Next]**.  
If a dialog box with an **"!**" or **"x"** symbol will appear, click **[Continue Anyway]** to proceed with the installation. If you are unable to continue, click **[OK]** and repeat the driver installation.  
(→**"Installing the Driver"** (p. 15))

**Windows 2000 users:**

If a dialog box indicating **"Digital Signature Not Found"** will appear, click **[Yes]** to proceed with the installation. If you are unable to continue, click **[OK]** and repeat the driver installation.  
(→**"Installing the Driver"** (p. 15))

2. The **Completing the Found New Hardware Wizard** dialog box will appear.  
Click **[Finish]**.
3. If the **Change System Settings** dialog box appears, click **[Yes]**. Windows will restart automatically.

If you are unable to complete driver installation using the above method, repeat the driver installation. (→**"Installing the Driver"** (p. 15))

## **Windows XP/2000 displays a “Hardware Installation” or “Digital Signature Not Found” dialog box**

### **Did you make “Driver Signing Options”?**

In order to install/re-install the driver, you must make the settings described in “Driver Signing Options” (p. 16).

## **“Find new hardware wizard” does not execute automatically “Find new hardware wizard” ends before the process is completed “Found unknown device” appears even though you installed the driver (Windows)**

### **Is the USB cable connected correctly?**

Make sure that the UM-3EX’s USB cable and your computer are correctly connected. It may take about 15 seconds (or more) after the USB cable is connected.

### **Does your computer or USB hub have sufficient power supply capacity?**

The UM-3EX cannot be connected if insufficient power is supplied to it. Check whether one of the following cases apply.

- If you are using the UM-3EX with a notebook computer that is running on its battery, operation may be unreliable with some models of computer. If this is the case, connect the AC adaptor to your notebook computer.
- The power conservation mode of your computer may limit the power that is supplied to USB. Check the settings of your computer.
- In some cases, the UM-3EX cannot be used with a bus-powered hub (a hub that does not contain a power supply). Please use a self-powered hub (a hub that contains a power supply).

### **Is USB enabled on your computer?**

Refer to the operation manual for your computer, and make sure that USB is enabled.

### **Does your computer meet the USB specifications?**

If you are using a computer that does not fulfill the electrical requirements of the USB specifications, operation may be unstable. In this case, you may be able to solve the problem by connecting a USB hub.

## **UM-3EX is not detected when making OMS or FreeMIDI settings (Mac OS 9 users)**

### **Is the UM-3EX detected?**

- Reconnect the UM-3EX.
- If other USB devices are connected, connect only the UM-3EX.
- It is possible that the Macintosh did not correctly detect and initialize the UM-3EX. Leave the UM-3EX connected, and restart your Macintosh. If it is still not detected, shut down your Macintosh, and then restart it.
- In some cases, the UM-3EX will not be detected if you have connected it to the USB connector located on the keyboard of the Macintosh. Please connect it to a USB connector on the Macintosh itself.

## Deleting the Driver

If you were unable to install the driver according to the procedure given, the UM-3EX may not be recognized correctly by the computer. In this case, use the following procedure to delete the driver, and then follow the procedure to install the driver once again.

### Windows users

1. Start up Windows with the UM-3EX disconnected.  
Disconnect all USB cables other than a USB keyboard or USB mouse.  
*\* If you are using Windows XP Professional/2000, log on as a user that has administrative privileges (e.g., Administrator).*
2. Insert the CD-ROM into the CD-ROM drive of your computer.
3. From the Windows **Start** menu, choose **Run....**  
In the **Run** dialog box, input the following into the **Open** field, and click **[OK]**.  
**Windows XP/2000 users:**      **D:\Driver\XP2k\Uninstal.exe**  
**Windows Me/98 users:**        **D:\Driver\Me98\Uninstal.exe**  
*\* The drive name is **D:** in the example shown here, but may be different on your system. Use the drive name for your CD-ROM drive.*
4. Follow the on-screen instructions to uninstall the driver.

### **Macintosh (Mac OS X) users**

1. Start up Macintosh with the UM-3EX disconnected.  
Disconnect all USB cables other than a USB keyboard or USB mouse.
2. Prepare the CD-ROM.  
Insert the CD-ROM into the CD-ROM drive of your Macintosh.
3. In the **Driver (Mac OS X)** folder of the CD-ROM, double-click **“UM3\_Uninstaller.”**
4. The display will indicate **“This uninstalls EDIROL UM-3 driver from this Macintosh.”**; click **[Uninstall]**.  
If any other message appears, proceed as directed by that message.
5. The display will indicate **“Are you sure to uninstall the driver?”**; click **[OK]**.
6. The **“Authenticate”** dialog box will appear; enter the password and click **[OK]**.
7. The display will indicate **“Uninstllation is completed.”**; click **[Restart]**. Your Macintosh will then restart.

### **Macintosh (Mac OS 9) users**

1. Start up Macintosh with the UM-3EX disconnected.  
Disconnect all USB cables other than a USB keyboard or USB mouse.
2. From the **system extensions folder** inside the **System folder**, drag **“USB UM-3 Driver”** into the trash to delete it.
3. Delete **“UM-3”** from the **OMS Folder** inside the **System folder**, or drag **“USB UM-3 Driver”** from the **FreeMIDI Folder** inside the **System folder** to the trash.
4. Restart the Macintosh.

# Problems When Using the UM-3EX

## Sound is interrupted during MIDI playback

### **In Windows XP/2000, did you make the setting described in “Giving priority to background services”?**

In order to ensure that MIDI processing occurs smoothly, make the setting described in “Giving priority to Background Services” (p. 18).

### **Did you plug in the USB cable, or unplug it while an software was running?**

Exit all software that are using the UM-3EX, and re-connect the UM-3EX.

### **Is your computer in Suspend or Sleep mode?**

If so, get your computer to resume normal operation, then exit all software that are using the UM-3EX. Next re-connect the UM-3EX.

### **Are you running multiple software?**

If multiple software are running simultaneously, an error message may appear. If this occurs, click [OK] and exit the other software.

Even if an software window is closed, it is still running if it appears in the taskbar. Be sure to exit unneeded software displayed.

## Playback or recording halts midway through, and then becomes impossible

### **Was a heavy processing load experienced while using the UM-3EX, such as accessing the CD-ROM drive or a network?**

If an operation involving a heavy processing load is performed while the UM-3EX is in use, it may not operate correctly. If this occurs, stop playback/recording, and then try resuming playback/recording. If you are still unable to play back/record, exit all software that use the UM-3EX, disconnect the UM-3EX from the computer and then reconnect it.

## Operating system becomes unstable

### **Operation becomes unstable when the computer is started up with the UM-3EX already connected**

Please start up your computer with the UM-3EX disconnected, and then connect the UM-3EX. On a computer that uses a USB keyboard, starting up the computer with the UM-3EX already connected may cause operation to become unstable. In this case, start up the computer with the UM-3EX disconnected, and then connect the UM-3EX.

# Main Specifications

## ■ UM-3EX: USB MIDI Interface

### **Controllers**

THRU switch 1  
THRU switch 2  
THRU switch 3  
MODE select switch  
UNIT number select switch

### **Connectors**

MIDI IN Connector x 3 (16 MIDI Channels x 3)  
MIDI OUT/THRU Connector x 3 (16 MIDI Channels x 3)  
USB Cable  
UM-3EX Connector x 2

### **Power Supply**

Supplied from the computer

### **Current Draw**

90 mA

### **Dimensions**

138 (W) x 67 (D) x 42 (H) mm  
5-7/16 (W) x 2-11/16 (D) x 1-11/16 (H) inches

### **Weight**

210 g / 8 oz

### **Accessories**

Owner's Manual  
CD-ROM

*\* In the interest of product improvement, the specifications, appearance, and/or contents of this unit are subject to change without prior notice.*



# Memo

# Name und Funktion der Bedienelemente

## Vorderseite

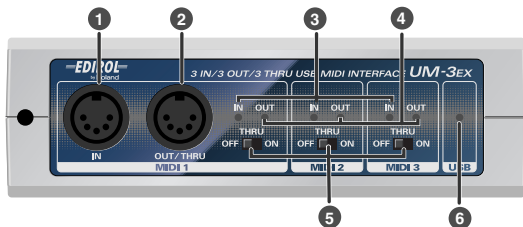

### 1 MIDI IN Anschlüsse

Hier stellen Sie eine Verbindung mit den MIDI OUT Anschlüssen der Geräte her (wie beispielsweise mit einem MIDI Keyboard), die MIDI-Signale an Ihren Computer senden werden.

### 2 MIDI OUT/THRU Anschlüsse

Hier stellen Sie eine Verbindung mit den MIDI IN Anschlüssen der Soundmodule oder der anderen Geräte her, an die Sie MIDI-Signale von Ihrem Computer zur Wiedergabe senden werden.

### 3 MIDI IN Anzeigen

Leuchten auf, wenn MIDI-Signale von den Geräten empfangen werden, die an den MIDI IN Anschlüssen angeschlossen sind.

### 4 MIDI OUT Anzeigen

Leuchten, wenn MIDI-Signale vom Computer übertragen werden.

### 5 THRU Schalter

Damit können Sie die Ausgabeziele für die MIDI-Signale wählen, die von den Geräten empfangen werden, die Sie an den MIDI IN Anschlüssen angeschlossen haben.

## ■ ON/OFF Einstellungen der THRU Schalter

Sie können die **THRU Schalter** verwenden, um die Übertragungsziele der MIDI-Signale von den Geräten (MIDI Keyboard, digitales Klavier etc.) zu wählen, die an die MIDI IN Anschlüsse angeschlossen sind. Die Kabelanschlüsse müssen dazu nicht verändern.

|                           |   |
|---------------------------|---|
| <b>THRU Schalter: OFF</b> | MIDI-Signale, die an dem entsprechenden MIDI IN Anschluss empfangen werden, werden an Ihren Computer (Sequenzersoftware) gesendet. Normalerweise sollten Sie diese Einstellung verwenden.   |
| <b>THRU Schalter: ON</b>  | MIDI-Signale, die an dem entsprechenden MIDI IN Anschluss des UM-3EX empfangen werden, werden vom entsprechenden MIDI OUT / THRU Anschluss des UM-3EX ausgegeben. Schalten Sie diesen Schalter ein, wenn Sie keine Sequenzersoftware verwenden. |

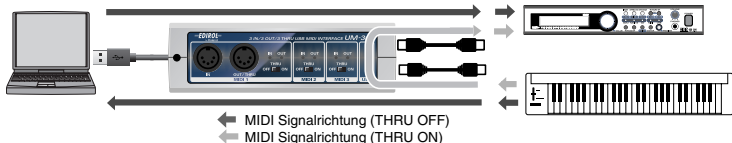

\* Verändern Sie die Einstellung eines **THRU Schalters** nicht während der Wiedergabe. Dies verursacht MIDI-Fehler.

## 6 USB-Anzeige

Diese Anzeige leuchtet, wenn Sie das UM-3EX an Ihren Computer angeschlossen haben und Ihr Computer das UM-3EX erkannt hat.

Damit Ihr Computer das UM-3EX erkennen kann, müssen Sie den Treiber installieren und Einstellungen vornehmen.

(→ "Anschlüsse herstellen und Treiber installieren (Windows)" (S. 62), "Anschlüsse herstellen und Treiber installieren (Macintosh)" (S. 66))

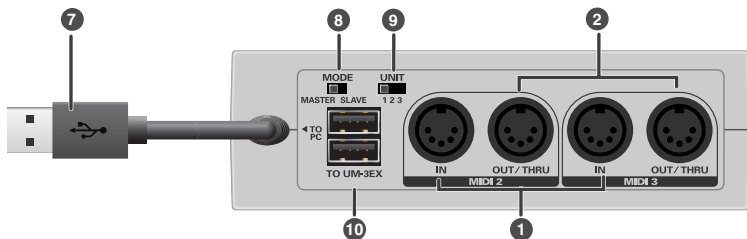

## 7 USB-Kabel

Schließen Sie das Kabel an den USB-Anschluss Ihres Computers an.

## 8 MODE Wahlschalter

Mit diesem Schalter kann eingestellt werden, ob das UM-3EX als Master- oder als Slave-Gerät arbeiten soll.

|   |  |
|---|--|
| <b>Wenn nur ein einzelnes UM-3EX verwendet wird</b> | Wählen Sie die Einstellung <b>MASTER</b> , wenn Sie nur ein UM-3EX verwenden.  |
| <b>Wenn mehrere UM-3EX verwendet werden</b>         | <ul style="list-style-type: none"> <li>• Wählen Sie die Einstellung <b>MASTER</b> bei dem UM-3EX, das an den Computer angeschlossen ist.</li> <li>• Wählen Sie die Einstellung <b>SLAVE</b> bei den UM-3EX, die an den UM-3EX Anschluss angeschlossen sind.</li> </ul> |

\* *Verändern Sie die Einstellung des MODE Wahlschalters nicht, solange das UM-3EX an Ihren Computer angeschlossen ist. Zuerst müssen Sie das UM-3EX von Ihrem Computer trennen. Nachdem Sie die Einstellung verändert haben, können Sie das UM-3EX wieder an den Computer anschließen.*

\* *Der Anschluss mehrerer Geräte wird nur von Windows XP und Mac OS X unterstützt. Detaillierte Informationen finden Sie unter **“Anschluss mehrerer UM-3EX Geräte”** (S. 72).*

## 9 UNIT Nummer-Wahlschalter

Bezeichnet die **UNIT Nummer** (Gerätenummer) des UM-3EX.

Wenn Sie mehrere UM-3EX anschließen, müssen Sie bei jedem Gerät die UNIT Nummer entsprechend einstellen. Dabei erhält jedes UM-3EX eine unterschiedliche UNIT Nummer.

*\* Verändern Sie die Einstellung des UNIT Wahlschalters nicht, solange das UM-3EX an Ihren Computer angeschlossen ist. Zuerst müssen Sie das UM-3EX von Ihrem Computer trennen. Nachdem Sie die Einstellung verändert haben, können Sie das UM-3EX wieder an den Computer anschließen.*

## 10 UM-3EX Anschlüsse

Verwenden Sie diesen Anschluss, wenn Sie mehrere UM-3EX verwenden.

*\* An den UM-3EX Anschluss dürfen keine anderen Geräte als ein UM-3EX angeschlossen werden. Dies würde zu einer Fehlfunktion des UM-3EX führen.*

# Anschlüsse herstellen und Treiber installieren (Windows)

## Vor dem Installieren des Treibers

Im Folgenden finden Sie die Beschreibung der Installation eines einzelnen UM-3EX.

Wenn Sie mit dem Betriebssystem Windows XP arbeiten, können Sie gleichzeitig bis zu drei UM-3EX Geräte über USB an einen Computer anschließen.

- \* *Der Anschluss mehrerer Geräte wird jedoch nur von Windows XP unterstützt. Weitere Informationen finden Sie unter **“Anschluss mehrerer UM-3EX Geräte”** (S. 72).*
- \* *Abhängig von dem von Ihnen verwendeten Computersystem kann das zweite oder dritte Gerät unter Umständen nicht funktionieren, weil Prozessorgeschwindigkeit, Speicherplatz auf der Festplatte und Leistung Ihrer Software möglicherweise nicht ausreichen.*

### ■ Bitte beim Anschluss unbedingt beachten

Stellen Sie den **MODE Wahlschalter** und den **UNIT Nummer-Wahlschalter** gemäß folgender Abbildung ein, bevor Sie das UM-3EX an Ihren Computer anschließen.

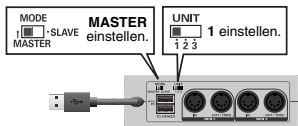

|                                 |                            |
|---------------------------------|----------------------------|
| <b>MODE Wahlschalter</b>        | Auf <b>MASTER</b> stellen. |
| <b>UNIT Nummer-Wahlschalter</b> | Auf <b>1</b> stellen.      |

- \* *Verändern Sie die Einstellung des **MODE Wahlschalter** oder des **UNIT Nummer-Wahlschalter** nicht, solange das UM-3EX an Ihren Computer angeschlossen ist. Zuerst müssen Sie das UM-3EX von Ihrem Computer trennen. Nachdem Sie die Einstellungen der Schalter verändert haben, können Sie das Gerät wieder an Ihren Computer anschließen.*

# Treiber installieren

## Was ist ein Treiber?

Ein **“Treiber”** ist eine Software, die Daten zwischen UM-3EX und der Anwendungssoftware auf Ihrem Computer überträgt, wenn Ihr Computer und UM-3EX miteinander verbunden sind. Der Treiber übermittelt Daten von Ihrer Anwendungssoftware an das UM-3EX und umgekehrt.

Schritte, die am UM-3EX vorgenommen werden müssen, sind mit **Operation of the UM-3EX** gekennzeichnet.

## Windows XP/2000-Anwender

1. Starten Sie Windows, wobei das UM-3EX nicht angeschlossen ist.

Das UM-3EX wird erst in Schritt 14 ( S. 65) an den Computer angeschlossen!

\* *Entfernen Sie sämtliche USB-Kabel außer denen der USB-Tastatur und der USB-Maus (falls vorhanden).*

\* *Melden Sie sich in Windows mit einem Benutzernamen an, der über Administrationsrechte verfügt (beispielsweise Administrator).*

2. Öffnen Sie das Dialogfeld **Systemeigenschaften**.

### Windows XP-Anwender:

1. Klicken Sie auf das Windows-**Start**-Menü und wählen Sie im Folgemenu **Systemsteuerung**.
2. Klicken Sie in **“Wählen Sie eine Kategorie”** auf **“Leistung und Wartung”**.
3. Klicken Sie in **“oder wählen Sie ein Systemsteuerungssymbol”** auf das Symbol **System**.  
Je nach Einstellung wird das Symbol **System** manchmal direkt in der klassischen Ansicht der **Systemsteuerung** angezeigt. Wenn dies der Fall ist, klicken Sie auf das Symbol **System**.

### Windows 2000-Anwender:

1. Klicken Sie auf das Windows-**Start**-Menü und wählen Sie im Folgemenu **Systemsteuerung**.
2. Doppelklicken Sie auf das **System**-Symbol in **Systemsteuerung** | **Einstellungen**.
3. Klicken Sie auf den Reiter **Hardware** und dann auf **[Treibersignatur]**.  
Daraufhin werden die **Treibersignaturoptionen** angezeigt.
4. Im Dialogfeld der **Treibersignaturoptionen** wählen Sie **“Ignorieren,”** und klicken dann auf **[OK]**.  
Wenn die aktuelle Einstellung **“Warnen”** oder **“Blockieren”** lautet, ändern Sie diese auf **“Ignorieren”**.  
Nach der Installation des Treibers stellen Sie die ursprüngliche Einstellung wieder her.

5. Klicken Sie auf **[OK]** zum Schließen des Dialogfelds **Systemeigenschaften**.
6. Beenden Sie alle aktuell ausgeführten Programme (Anwendungen). Schließen Sie außerdem alle noch geöffneten Programmfenster. Wenn Sie eine Anti-Virus- oder ähnliche Software benutzen, müssen Sie diese Programme ebenfalls beenden.
7. Halten Sie die CD-ROM bereit.  
Legen Sie die CD-ROM in das CD-ROM-Laufwerk Ihres Computers.  
*\* Wenn die Meldung **“Windows kann jedes Mal, wenn Sie eine Diskette einlegen oder ein Gerät mit dieser Dateart anschließen, die gleiche Aktion ausführen”** angezeigt wird, klicken Sie auf **[Abbrechen]**.*
8. Wählen Sie **Ausführen...** aus dem Windows-**Start**-Menü.
9. Geben Sie im **offenen** Feld des Dialogfeldes **Ausführen...** Folgendes ein und klicken Sie danach auf **[OK]**.  
**D: \Driver\XP2k\Setup.exe**  
*\* Der Laufwerkname **“D:”** in diesem Beispiel kann aber auf Ihrem System ein anderer sein. Geben Sie den Laufwerknamen Ihres CD-ROM-Laufwerks an.*
10. Daraufhin wird die Dialogbox **Treiber-Setup** angezeigt.  
Klicken Sie auf **[Weiter]**.
11. Um die Installation zu beginnen, klicken Sie noch einmal auf **[Weiter]**. Die Installation beginnt dann.

### **Windows XP-Anwender:**

Wenn die **“Treibersignaturoptionen”** in Schritt vier auf etwas anderes als **“Ignorieren”** eingestellt sind, erscheint ein Dialogfeld mit einem **“!**“ oder **“x”**. Wenn **[Installation fortsetzen]** angezeigt wird, klicken Sie auf **[Installation fortsetzen]**. Wenn Sie nicht fortfahren können, klicken Sie auf **[OK]** und wiederholen die Installation des Treibers ab Schritt eins.

### **Windows 2000-Anwender:**

Wenn die **“Treibersignaturoptionen”** in Schritt vier auf etwas anderes als **“Ignorieren”** eingestellt sind, erscheint ein Dialogfeld mit dem Hinweis **“Digitale Signatur nicht gefunden”**. Wenn **[Ja]** angezeigt wird, klicken Sie auf **[Ja]**, um die Installation fortzusetzen. Wenn Sie nicht fortfahren können, klicken Sie auf **[OK]** und wiederholen die Installation des Treibers ab Schritt eins.

Das Dialogfeld **“Setup is now ready to install the drivers”** (Setup ist jetzt bereit, die Treiber zu installieren) erscheint.



**12. Operation of the UM-3EX** Stellen Sie den **MODE Wahlschalter** des UM-3EX auf **MASTER**.

**13. Operation of the UM-3EX** Stellen Sie den **UNIT Nummer-Wahlschalter** des UM-3EX auf **1**.

**14. Operation of the UM-3EX** Schließen Sie nur ein UM-3EX an Ihren Computer an.

Die Mitteilung "**Neue Hardware gefunden**" erscheint. Bitte warten Sie.

\* *Dieses Gerät ist mit einem Schutzschaltkreis ausgestattet. Nach dem Anschluss des UM-3EX benötigt das Gerät eine kurze Zeitspanne von einigen Sekunden, bis es den normalen Betrieb aufnimmt.*

### Windows XP-Anwender:

1. Der **Assistent Neue Hardware gefunden** erscheint. Wenn die Meldung "**Mit Windows Update verbinden, um neue Software zu suchen?**" erscheint, wählen Sie "**Nein**" und klicken auf **[Weiter]**.

2. Stellen Sie sicher, dass "**EDIROL UM-3**" angezeigt wird. Wählen Sie danach "**Nach dem besten Treiber suchen**" und klicken Sie auf **[Weiter]**.

\* *Wenn die "**Treibersignaturoptionen**" in Schritt vier auf etwas anderes als "**Ignorieren**" eingestellt sind, erscheint ein Dialogfeld mit einem "I". Klicken Sie auf **[Installation fortsetzen]**, um mit der Installation fortzufahren.*

### Windows 2000-Anwender:

Wenn die "**Treibersignaturoptionen**" in Schritt vier auf etwas anderes als "**Ignorieren**" eingestellt sind, erscheint ein Dialogfeld mit dem Hinweis "**Digitale Signatur nicht gefunden**". Klicken Sie auf **[Ja]**, um mit der Installation fortzufahren.

**15.** Es erscheint die Dialogbox **Abschließen der Installation neuer Hardware**.

Klicken Sie auf **[Fertig stellen]**.

**16.** Klicken Sie in der Dialogbox **Treiber-Setup** auf **[Schließen]**.

Wenn die Dialogbox **Systemeigenschaften ändern** erscheint, klicken Sie auf **[Ja]**. Windows startet automatisch neu.

\* *Wenn Sie die Einstellungen der "**Treibersignaturoptionen**" in Schritt vier geändert haben, stellen Sie wieder die ursprünglichen Einstellungen her, nachdem Windows neu gestartet hat.*

# Anschlüsse herstellen und Treiber installieren (Macintosh)

## Vor dem Installieren des Treibers

Im Folgenden finden Sie die Beschreibung der Installation eines einzelnen UM-3EX.

Wenn Sie mit dem Betriebssystem Mac OS X arbeiten, können Sie gleichzeitig bis zu drei UM-3EX Geräte über USB an einen Macintosh anschließen.

- \* *Der Anschluss mehrerer Geräte wird nur von Mac OS X unterstützt. Detaillierte Informationen finden Sie unter **“Anschluss mehrerer UM-3EX Geräte”** (S. 72).*
- \* *Abhängig von dem von Ihnen verwendeten Computersystem kann das zweite oder dritte Gerät unter Umständen nicht funktionieren, weil Prozessorgeschwindigkeit, Speicherplatz auf der Festplatte und Leistung Ihrer Software möglicherweise nicht ausreichen.*

### ■ Bitte beim Anschluss unbedingt beachten

Stellen Sie den **MODE Wahlschalter** und den **UNIT Nummer-Wahlschalter** gemäß folgender Abbildung ein, bevor Sie das UM-3EX an Ihren Macintosh anschließen.

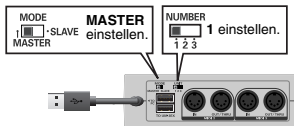

|                                 |                            |
|---------------------------------|----------------------------|
| <b>MODE Wahlschalter</b>        | Auf <b>MASTER</b> stellen. |
| <b>UNIT Nummer-Wahlschalter</b> | Auf <b>1</b> stellen.      |

- \* *Verändern Sie die Einstellung des **MODE Wahlschalter** oder des **UNIT Nummer-Wahlschalter** nicht, solange das UM-3EX an Ihren Computer angeschlossen ist. Zuerst müssen Sie das UM-3EX von Ihrem Macintosh trennen. Nachdem Sie die Einstellungen der Schalter verändert haben, können Sie das Gerät wieder an Ihren Macintosh anschließen.*

# Installation und Einstellungen des Treibers

## Was ist ein Treiber?

Ein **“Treiber”** ist eine Software, die Daten zwischen UM-3EX und der Anwendungssoftware auf Ihrem Macintosh überträgt, wenn Ihr Macintosh und UM-3EX miteinander verbunden sind. Der Treiber übermittelt Daten von Ihrer Anwendungssoftware an das UM-3EX und umgekehrt.

Schritte, die am UM-3EX vorgenommen werden müssen, sind mit **Operation of the UM-3EX** gekennzeichnet.

## Mac OS X-Anwender

### ■ Treiberinstallation

\* Geben Sie in das eventuell erscheinende Dialogfeld **“Authenticate”** (Authentifizierung) das Kennwort ein und klicken Sie auf **“OK”**.

\* Die aktuelle Anzeige auf Ihrem Computerbildschirm kann anders aussehen und hängt davon ab, welchen Computer und welches Betriebssystem Sie nutzen.

**1.** Starten Sie Ihren Macintosh, wobei das UM-3EX nicht angeschlossen ist.

\* Lösen Sie alle USB-Kabel außer der USB-Tastatur und der USB-Maus von Ihrem Computer und starten Sie den Macintosh neu.

**2.** Beenden Sie alle aktuell ausgeführten Programme (Anwendungen).

**3.** Halten Sie die CD-ROM bereit.

Legen Sie die CD-ROM in das CD-ROM-Laufwerk Ihres Macintosh ein.

**4.** Doppelklicken Sie im Ordner **Driver (Mac OS X)** auf der CD-ROM auf **UM3USBDriver.pkg**.

Es kann eine Mitteilung wie **“This Installer package needs to...”** erscheinen.

Klicken Sie auf **“Continue”**.

**5.** In der Anzeige erscheint **“Welcome to the EDIROL UM-3Driver Installer”**.

Klicken Sie auf **[Continue]**.

**6.** In der Anzeige erscheint **“Select a Destination”**.

Wählen Sie mit einem Mausclick das Laufwerk aus, auf dem das Betriebssystem installiert ist, und klicken Sie dann auf **[Continue]**.

\* Wählen Sie Ihre Bootfestplatte als Laufwerk.

**7.** In der Anzeige erscheint **“Easy Install”**.

Klicken Sie auf **[Install]** oder **[Upgrade]**.

8. In der Anzeige erscheint **“Installing this software requires you to restart your computer when the installation is done”** (Neustart nach Installation erforderlich).  
Klicken Sie auf **[Continue Installation]** (Installation fortsetzen).
9. In der Anzeige erscheint **“The software was successfully installed”** (Die Software wurde erfolgreich installiert).  
Klicken Sie auf **[Restart]**, um Ihren Macintosh neu zu starten.

Damit ist die Installation des UM-3EX Treibers abgeschlossen.  
Als nächstes nehmen Sie MIDI-Geräteeinstellungen vor. (→ **“Konfiguration des Treibers”** (S. 68))

## ■ Konfiguration des Treibers

Im Folgenden werden die Einstellungen beschrieben, durch die Sie das UM-3EX mit der Sequenzer- software und den Macintosh Standardgeräteeinstellungen benutzen können.  
Wenn Sie eine Sequenzer- software nutzen, die keine Macintosh Standardgeräteeinstellungen verwendet, nehmen Sie die Geräteeinstellungen in der Sequenzer- software vor.

\* Die aktuelle Anzeige auf Ihrem Computerbildschirm kann anders aussehen und hängt davon ab, welchen Computer und welches Betriebssystem Sie nutzen.

1. **Operation of the UM-3EX** Stellen Sie den **MODE Wahlschalter** des UM-3EX auf **MASTER**.
2. **Operation of the UM-3EX** Stellen Sie den **UNIT Nummer-Wahlschalter** des UM-3EX auf **1**.
3. **Operation of the UM-3EX** Schließen Sie nur ein UM-3EX an Ihren Macintosh an.  
\* Verbinden Sie das Kabel mit dem **USB-Anschluss** direkt mit dem Macintosh, nicht mit der **USB-Buchse** der Tastatur.  
\* Dieses Gerät ist mit einem **Schutzschaltkreis** ausgestattet. Nach dem Anschluss des UM-3EX benötigt das Gerät eine kurze Zeitspanne von einigen Sekunden, bis es den normalen Betrieb aufnimmt.
4. Öffnen Sie den Ordner **Applications** (Anwendungen) auf der Festplatte Ihres Macintosh. Doppel- klicken Sie auf **Audio MIDI Setup** im Ordner **Utilities** (Dienstprogramme) zum Öffnen des **Audio MIDI Setup**.



5. Klicken Sie auf die Registerkarte **MIDI-Devices**.

**6.** Stellen Sie sicher, dass **1: UM-3** im Dialogfenster des **Audio MIDI Setup** erscheint.

- \* Die Nummer "1:" zu Beginn des Gerätes ist die Gerätenummer des UM-3EX. Dieser Wert ist abhängig von der Einstellung des UNIT Nummer-Wahlschalters.
  - \* Wenn "1: UM-3" nicht erscheint oder grau unterlegt ist, wurde das UM-3EX nicht korrekt erkannt. Klicken Sie dann auf **Rescan MIDI**. Sie können auch versuchen, das UM-3EX vom Computer zu trennen und danach wieder anzuschließen.
  - \* Frühere Einstellungen bei der Installation einer anderen Treiberversion können immer noch aktiv sein. In diesem Fall klicken Sie auf das grau unterlegte "1: UM-3", um es auszuwählen und danach auf **Remove Selected Device**, um die Einstellungen zu löschen.
- 7.** Klicken Sie dreimal auf **Add Device** (Gerät hinzufügen).  
Drei **New External Device** erscheint.

**8.** Geben Sie den **Gerätenamen** für jedes **neue externe Gerät** an.

1. Klicken Sie auf das hinzugefügte **new external device** und danach auf **Show Info**.
2. Geben Sie den Namen in dem Feld **Device Name** ein.

|                               |           |
|-------------------------------|-----------|
| <b>Erstes externes Gerät</b>  | 1: UM-3 1 |
| <b>Zweites externes Gerät</b> | 1: UM-3 2 |
| <b>Drittes externes Gerät</b> | 1: UM-3 3 |

- \* Geben Sie die UNIT Gerätenummer des UM-3EX als erste Nummer "1:" an.



9. Ziehen Sie Mit der Maus die Symbole ▼ und ▲, die für die Eingänge und Ausgänge des **1: UM-3** und des **neuen externen Gerätes** stehen, dass sie folgendermaßen verbunden sind.

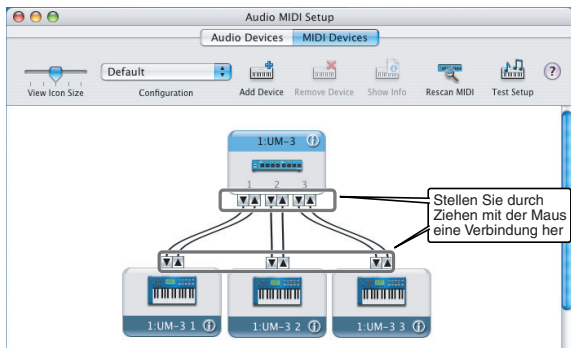

**10. Bei Verwendung von Mac OS X v10.2:**

Schließen Sie das **Audio MIDI Setup** Fenster. Die Einstellungen sind beendet.

**Bei Verwendung von Mac OS X v10.3 oder spätere Version:**

Bestätigen Sie, dass MIDI übertragen und korrekt empfangen wurde. Führen Sie die Schritte 11–14 (S. 71) durch.

## 11. Klicken Sie auf **Test Setup**.

Die Form des Mauszeigers verändert sich ♪.

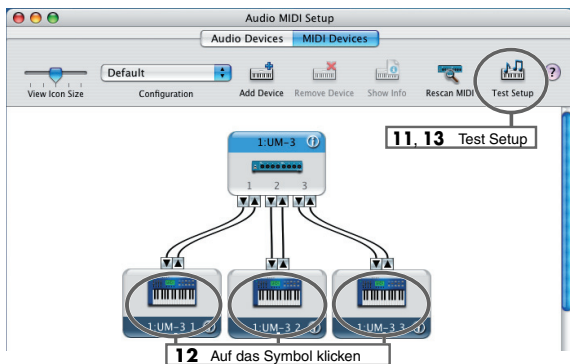

12. Klicken Sie auf den in der Illustration gezeigten Bereich. Wenn die entsprechende MIDI OUT Anzeige des UM-3EX blinkt, sind die Einstellungen korrekt.

13. Klicken Sie auf **Test Setup** und vollenden Sie die Bestätigung.

14. Schließen Sie das **Audio MIDI Setup** Fenster.

### Bei Verwendung des UM-3EX mit Ihrer Sequenzersoftware

Bitte lesen Sie die folgenden Punkte, bevor Sie das UM-3EX mit Ihrer Sequenzersoftware verwenden.

- Schließen Sie das UM-3EX an Ihren Macintosh an, bevor Sie Ihre Sequenzersoftware starten.
- Trennen Sie das UM-3EX nicht von Ihrem Macintosh so lange die Sequenzersoftware läuft. Beenden Sie Ihre Sequenzersoftware, bevor Sie das UM-3EX von Ihrem Macintosh trennen.
- Das UM-3EX funktioniert nicht in der Mac OS X Classic-Umgebung. Verwenden Sie das UM-3EX, wenn die Classic-Umgebung nicht ausgeführt wird.

## Anschluss mehrerer UM-3EX Geräte

Wenn Sie mit den Betriebssystemen Windows XP oder Mac OS X arbeiten, können Sie gleichzeitig bis zu drei UM-3EX Geräte über USB an einen einzelnen Computer anschließen. Abhängig von dem von Ihnen verwendeten Computersystem kann das zweite oder dritte Gerät unter Umständen nicht funktionieren, weil Prozessorgeschwindigkeit, Speicherplatz auf der Festplatte und Leistung Ihrer Software möglicherweise nicht ausreichen.

\* Der Anschluss mehrerer Geräte wird jedoch nur von Windows XP und Mac OS X unterstützt.

### ■ UNIT Nummer

Wenn Sie mehrere UM-3EX anschließen, müssen Sie bei jedem Gerät die UNIT Nummer entsprechend einstellen. Dabei erhält jedes UM-3EX eine unterschiedliche UNIT Nummer. Die UNIT Nummer wird angezeigt als "1:" oder "2:" etc. zu Beginn des MIDI Gerätenamens. Der Wert von "1:" oder "2:" hängt von der Einstellung des UNIT Nummer-Wahlschalters ab.

### ■ Anschluss von drei UM-3EX Geräten

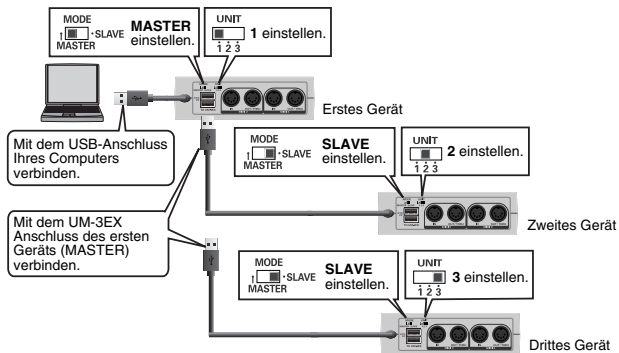



## Einstellungen der **MODE** Wahlschalter und **UNIT Nummer-Wahlschalter**

|                                 |   |
|---------------------------------|---|
| <b>MODE Wahlschalter</b>        | <ul style="list-style-type: none"><li>• Wählen Sie die Einstellung <b>MASTER</b> bei dem UM-3EX, das an den Computer angeschlossen ist.</li><li>• Wählen Sie die Einstellung <b>SLAVE</b> bei den UM-3EX, die an den UM-3EX Anschluss angeschlossen sind.</li></ul> |
| <b>UNIT Nummer-Wahlschalter</b> | <ul style="list-style-type: none"><li>• Stellen Sie das erste Gerät auf <b>1</b>.</li><li>• Stellen Sie das zweite Gerät auf <b>2</b>.</li><li>• Stellen Sie das dritte Gerät auf <b>3</b>.</li></ul>   |

\* *Verändern Sie die Einstellung des **MODE Wahlschalter** oder des **UNIT Nummer-Wahlschalter** nicht, solange das UM-3EX an Ihren Computer angeschlossen ist. Zuerst müssen Sie das UM-3EX von Ihrem Computer trennen. Nachdem Sie die Einstellungen der Schalter verändert haben, können Sie das Gerät wieder an Ihren Computer anschließen.*

Nehmen Sie keine der folgenden Anschlüsse vor.

### UM-3EX auf **SLAVE** eingestellt und an einen Computer angeschlossen

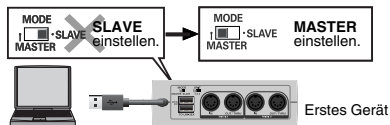

### UM-3EX auf **MASTER** eingestellt und an ein UM-3EX angeschlossen

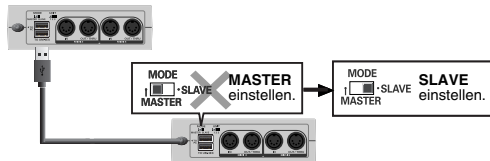

# Description

## Face avant

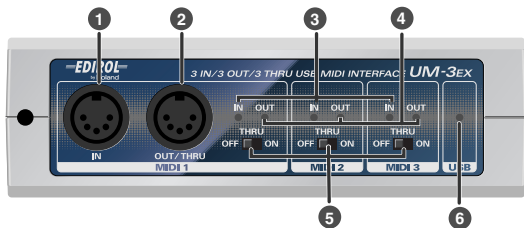

### 1 Connecteurs MIDI IN

Permettent le branchement des connecteurs MIDI OUT des périphériques (par ex. un clavier MIDI) qui transmettront des signaux MIDI à votre ordinateur.

### 2 Connecteurs MIDI OUT/THRU

Permet le branchement des connecteurs MIDI IN de modules de sonorisation ou d'autres périphériques vers lesquels l'ordinateur envoie des messages MIDI pour les lire.

### 3 Voyants MIDI IN

S'allument lorsque les messages MIDI sont reçus à partir de périphériques branchés sur les connecteurs MIDI IN.

### 4 Voyants MIDI OUT

S'allument lorsque des messages MIDI sont transmis par l'ordinateur.

### 5 Commutateurs THRU

Permettent de sélectionner les destinations de sortie des messages MIDI reçus à partir de périphériques branchés sur les connecteurs MIDI IN.

## ■ Paramétrage ON/OFF des commutateurs THRU

Les **commutateurs THRU** permettent de sélectionner les destinations de transmission des messages MIDI provenant des périphériques (clavier MIDI, piano numérique, etc.) branchés sur les connecteurs MIDI IN. Il n'est pas nécessaire de modifier les connexions des câbles.

|                               |   |
|-------------------------------|---|
| <b>Commutateur THRU : OFF</b> | les messages MIDI arrivant par le connecteur MIDI IN correspondant sont envoyés vers votre ordinateur (logiciel séquenceur). C'est en principe le paramètre à utiliser.   |
| <b>Commutateur THRU : ON</b>  | Les messages MIDI arrivant sur l'UM-3EX via le connecteur MIDI IN correspondant sortent par le connecteur MIDI OUT/THRU correspondant de l'UM-3EX. Désactiver cette option si le logiciel séquenceur n'est pas utilisé. |

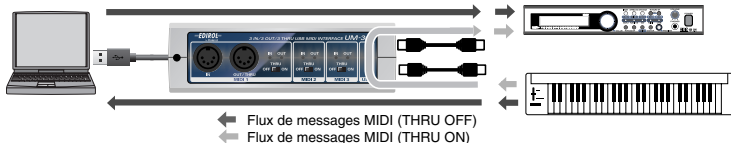

\* Ne pas modifier le paramétrage d'un **commutateur THRU** pendant la lecture pour éviter de générer des erreurs MIDI.

## 6 Voyant USB

S'allume lorsque l'UM-3EX est branché à un ordinateur et que celui-ci l'a détecté.

Installer le pilote et procéder aux paramétrages qui s'imposent pour que l'ordinateur puisse détecter l'UM-3EX.

(→ "Connexion et installation des pilotes (Windows)" (p. 78), "Connexions et installation des pilotes (Macintosh)" (p. 82))

## Face arrière

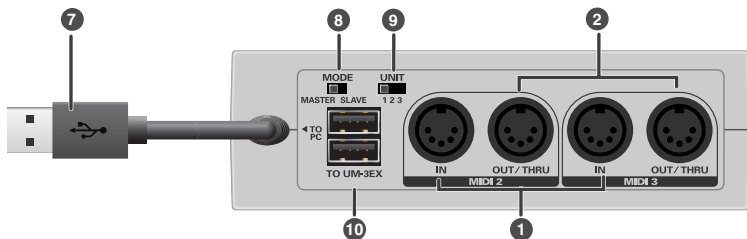

### 7 Câble USB

Connecter ce câble sur le connecteur USB de votre ordinateur.

### 8 Sélecteur de MODE

Ce sélecteur permet de déterminer si l'UM-3EX fonctionne en maître ou en esclave.

|  |   |
|--|---|
| <b>Lorsqu'une seule unité UM-3EX est utilisée</b>      | Sélectionner <b>MASTER</b> lorsqu'une seule unité UM-3EX est utilisée.  |
| <b>Lorsque plusieurs unités UM-3EX sont connectées</b> | <ul style="list-style-type: none"><li>• Sélectionner le paramètre <b>MASTER</b> pour l'unité UM-3EX connectée à l'ordinateur.</li><li>• Sélectionner le paramètre <b>SLAVE</b> pour les unités UM-3EX branchées sur le connecteur UM-3EX.</li></ul> |

\* Ne pas modifier la position du sélecteur de MODE pendant que l'UM-3EX est connecté à l'ordinateur. Avant toute chose, débrancher l'UM-3EX de l'ordinateur. Il peut être reconnecté une fois la position du sélecteur modifiée.

\* Seuls Windows XP et Mac OS X prennent en charge la connexion d'unités multiples. Pour plus d'informations, voir "**Connexion de plusieurs unités UM-3EX**" (p. 88).

### 9 **Sélecteur du numéro d'UNITÉ**

Définit le **d'UNITÉ** de l'UM-3EX.

Lorsque plusieurs unités UM-2EX sont connectées, le sélecteur doit définir correctement le numéro de chacune. Sélectionner un numéro d'UNITÉ différent pour chaque UM-3EX.

*\* Ne pas modifier le numéro d'UNITÉ pendant que l'UM-3EX est connecté à l'ordinateur. Avant toute chose, débrancher l'UM-3EX de l'ordinateur. Il peut être reconnecté une fois la position du sélecteur modifiée.*

### 10 **Connecteurs UM-3EX**

Servent à connecter plusieurs unités UM-3EX.

*\* Ne brancher aucun périphérique autre que UM-3EX sur ce type de connecteur pour éviter tout dysfonctionnement de l'UM-3EX.*

# Connexion et installation des pilotes (Windows)

## Avant d'installer le pilote

Procédure d'installation d'un seul UM-3EX.

Si vous utilisez Windows XP, vous pouvez connecter simultanément jusqu'à trois unités UM-3EX à un seul ordinateur via USB.

- \* *Seul Windows XP prend en charge la connexion d'unités multiples. Pour plus d'informations, voir "Connexion de plusieurs unités UM-3EX" (p. 88).*
- \* *En fonction du système utilisé, la seconde unité ou l'unité suivante ne sera peut-être pas utilisable. Cela dépend des limites imposées par la vitesse de l'unité centrale, le disque dur, la mémoire et les performances de votre logiciel.*

### ■ Précautions lors du branchement

Paramétrer le **sélecteur de MODE** et le **sélecteur du numéro d'UNITÉ** avant de brancher l'UM-3EX sur l'ordinateur.

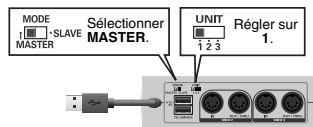

|                                    |                                |
|------------------------------------|--------------------------------|
| <b>Sélecteur de MODE</b>           | Paramétrer sur <b>MASTER</b> . |
| <b>Sélecteur du numéro d'UNITÉ</b> | Régler sur <b>1</b> .          |

- \* *Ne pas modifier la position du **sélecteur de MODE** ou le **sélecteur du numéro d'UNITÉ** pendant que l'UM-3EX est connecté à l'ordinateur. Avant toute chose, débrancher l'UM-3EX de l'ordinateur. Il peut être reconnecté une fois la position du sélecteur modifiée.*

# Installation du pilote spécial

## Qu'est-ce qu'un pilote ?

Un "**pilote**" est un logiciel qui sert à transférer les données entre l'UM-3EX et le logiciel tournant sur votre ordinateur, lorsque votre ordinateur et l'UM-3EX sont reliés. Le pilote transmet les données de l'application à l'UM-3EX et vice-versa.

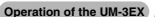
Les opérations à exécuter sur l'UM-3EX sont signalées par le symbole  .

## Windows XP/2000

1. L'UM-3EX n'étant pas branché, lancer Windows.  
Ne pas raccorder l'UM-3EX à l'ordinateur avant le point 14 (p. 81).  
*\* Débrancher tous les câbles USB, à l'exception de ceux du clavier et de la souris (le cas échéant).*  
*\* Ouvrir une session Windows en tant qu'utilisateur doté de droits d'administration (Administrateur, par exemple).*
2. Ouvrir la boîte de dialogue **Propriétés système**.

### Utilisateurs de Windows XP :

1. Cliquer sur le menu **Démarrer** de Windows et sélectionner **Panneau de configuration**.
2. Dans "**Choisissez une catégorie**", cliquer sur "**Performances et maintenance**".
3. Dans "**ou choisissez une icône du Panneau de configuration**", cliquer sur l'icône **Système**. Selon la configuration, l'icône **Système** peut s'afficher directement dans le **Panneau de configuration** (Vue classique). Dans ce cas, double-cliquer sur l'icône **Système**.

### Windows 2000 :

1. Cliquer sur le menu **Démarrer** de Windows et sélectionner **Paramètres** | **Panneau de configuration** dans le menu qui s'affiche.
2. Dans le **Panneau de configuration**, double-cliquer sur l'icône **Système**.
3. Cliquer sur l'onglet **Matériel**, puis cliquer sur **[Signature du pilote]**.  
La boîte de dialogue **Options de signature du pilote** s'affiche.
4. Dans la boîte de dialogue **Options de signature du pilote**, sélectionner "**Ignorer**" et cliquer sur **[OK]**.  
Si le paramètre actuel est "Avertir" ou "Bloquer", le remplacer par "**Ignorer**". Rétablir le paramètre précédent après installation du pilote.

5. Cliquer sur **[OK]** pour fermer la boîte de dialogue **Propriétés système**.

6. Fermer tous les logiciels (applications) actifs.

Fermer également toutes les fenêtres éventuellement ouvertes. Tout programme de type antivirus, etc., en cours d'exécution doit être fermé également.

7. Se munir du CD-ROM

et l'introduire dans le lecteur de l'ordinateur.

\* Si le message "**Windows peut effectuer la même action à chaque fois que vous insérez un disque ou connectez un périphérique avec ce type de fichier**" s'affiche, cliquer sur **[Annuler]**.

8. Cliquer sur le bouton **Démarrer** de Windows et sélectionner l'option **Exécuter...**

9. Dans le champ **Ouvrir** de la boîte de dialogue **Exécuter...**, saisir le chemin d'accès suivant et cliquer sur **[OK]**.

**D: \Driver\XP2k\Setup.exe**

\* La lettre du lecteur est **D:** dans l'exemple qui nous occupe, mais elle peut être différente sur votre ordinateur. Saisir la lettre affectée au lecteur utilisé.

10. La boîte de dialogue **Paramétrage du pilote** s'affiche.

Cliquer **[Suivant]**.

11. Cliquer une nouvelle fois sur **[Suivant]** pour lancer l'installation. L'installation commence.

### **Utilisateurs de Windows XP :**

Si le paramètre "**Options de signature du pilote**" (point 4) est autre que "**Ignorer**", une boîte de dialogue comportant le symbole "**!**" ou "**x**" s'affiche. Si le bouton **[Continuer]** est présent, il suffit de cliquer sur celui-ci pour poursuivre l'installation. Dans le cas contraire, cliquer sur **[OK]** et reprendre l'installation du pilote à partir du point 1.

### **Windows 2000 :**

Si le paramètre "**Options de signature du pilote**" (point 4) est autre que "**Ignorer**", une boîte de dialogue comportant le message "**Signature numérique introuvable**" s'affiche. Si le bouton **[Yes]** est présent, cliquer sur celui-ci pour poursuivre l'installation. Dans le cas contraire, cliquer sur **[OK]** et reprendre l'installation du pilote à partir du point 1.

La boîte de dialogue "**Installation des pilotes prête à démarrer**" s'affiche.



**12.** Placer le **Operation of the UM-3EX** sélecteur de **MODE** de l'UM-3EX sur la position **MASTER**.

**13.** **Operation of the UM-3EX** Positionner le **Sélecteur du numéro d'UNITÉ** de l'UM-3EX sur 1.

**14.** **Operation of the UM-3EX** Ne connecter qu'un seul UM-3EX sur l'ordinateur.

Le message "**Nouveau matériel détecté**" s'affiche. Veuillez patienter.

\* *Cet appareil est équipé d'un circuit de protection. Une fois l'UM-3EX raccordé à l'ordinateur, laisser s'écouler quelques secondes avant de l'utiliser.*

#### **Utilisateurs de Windows XP :**

1. La boîte de dialogue **Assistant de nouveau matériel détecté** s'affiche. Si le message "**se connecter aux mises à jour Windows pour rechercher le logiciel?**" s'affiche, sélectionner "**Non**" et cliquer sur **[Suivant]**.

2. S'assurer que la mention "**EDIROL UM-3**" est présente. Sélectionner alors l'option "**chercher le meilleur pilote dans les endroits sélectionnés**" et cliquer sur **[Suivant]**.

\* *Si le paramètre "**Options de signature du pilote**" (point 4) est autre que "**Ignorer**", une boîte de dialogue comportant le symbole "!" s'affiche. Cliquer sur **[Continuer]** pour poursuivre l'installation.*

#### **Windows 2000:**

Si le paramètre "**Options de signature du pilote**" (point 4) est autre que "**Ignorer**", une boîte de dialogue comportant le message "**Signature numérique introuvable**" s'affiche. Cliquer sur **[Oui]** pour poursuivre l'installation.

**15.** La boîte de dialogue **Fin Assistant nouveau matériel** s'affiche.

Cliquer sur **[Terminer]**.

**16.** Dans la boîte de dialogue **Paramétrage du pilote**, cliquer sur **[Fermer]**.

Si la boîte de dialogue **Modification des paramètres système** s'affiche, cliquer sur **[Oui]**. Windows redémarre automatiquement.

\* *Si l'on a modifié les "**Options de signature du pilote**" (point 4), rétablir la configuration d'origine après redémarrage de Windows.*

# Connexions et installation des pilotes (Macintosh)

## Avant d'installer le pilote

Procédure d'installation d'un seul UM-3EX.

Les utilisateurs de Mac OS X peuvent connecter simultanément jusqu'à trois unités UM-3EX sur un seul Macintosh via USB.

- \* *Seul Mac OS X prend en charge la connexion d'unités multiples. Pour plus d'informations, voir "**Connexion de plusieurs unités UM-3EX**" (p. 88).*
- \* *En fonction du système utilisé, la seconde unité ou l'unité suivante ne sera peut-être pas utilisable. Cela dépend des limites imposées par la vitesse de l'unité centrale, le disque dur, la mémoire et les performances de votre logiciel.*

### ■ Précautions lors du branchement

Paramétrer le **sélecteur de MODE** et le **sélecteur du numéro d'UNITÉ** avant de brancher l'UM-3EX sur le Macintosh.



|                                    |                                |
|------------------------------------|--------------------------------|
| <b>Sélecteur de MODE</b>           | Paramétrer sur <b>MASTER</b> . |
| <b>Sélecteur du numéro d'UNITÉ</b> | Régler sur 1.                  |

- \* *Ne pas modifier la position du **sélecteur de MODE** ou le **sélecteur du numéro d'UNITÉ** pendant que l'UM-3EX est connecté à l'ordinateur. Avant toute chose, débrancher l'UM-3EX du Macintosh. Il peut être reconnecté une fois la position du sélecteur modifiée.*

# Installation et configuration du pilote

## Qu'est-ce qu'un pilote ?

Un “**pilote**” est un logiciel qui sert à transférer les données entre l'UM-3EX et le logiciel tournant sur le Macintosh lorsque celui-ci et l'UM-3EX sont reliés. Le pilote transmet les données de l'application à l'UM-3EX et vice-versa.

Les opérations à exécuter sur l'UM-3EX sont signalées par le symbole **Operation of the UM-3EX**.

## Utilisateurs de Mac OS X

### ■ Installation du pilote

\* Si la boîte de dialogue “**Authenticate**” s'affiche pendant l'installation, introduire le mot de passe et cliquer sur “**OK**”.

\* Les données affichées à l'écran peuvent varier selon le type d'ordinateur et de système d'exploitation utilisé.

**1.** L'UM-3EX n'étant pas branché, démarrer le Macintosh.

\* *Débrancher tous les câbles USB, à l'exception de ceux du clavier et de la souris, puis redémarrer l'ordinateur.*

**2.** Fermer tous les logiciels (applications) actifs.

**3.** Se munir du CD-ROM.

et l'introduire dans le lecteur de l'ordinateur.

**4.** Dans le dossier **Driver (Mac OS X)** du CD-ROM, double-cliquer sur **UM3USBDriver.pkg**.

Un message du genre “**This Installer package needs to...**” s'affiche éventuellement.

Cliquer sur “**Continue**”.

**5.** L'écran affiche “**Welcome to the EDIROL UM-3Driver Driver Installer**”.

Cliquer sur [**Continue**].

**6.** L'écran indique “**Select a Destination**” pour vous inviter à sélectionner l'emplacement de l'installation.

Cliquer sur le lecteur dans lequel le système est installé pour le sélectionner, puis cliquer sur [**Continue**].

\* *Le disque à sélectionner est le disque de démarrage.*

**7.** “**Easy Install**” s'affiche.

Clique sur [Install] ou [Upgrade].

**8.** L'écran indique “**Installing this software requires you to restart your computer when the installation is done**”. (Lorsque vous installez le logiciel, vous devez redémarrer votre ordinateur à la fin de l'installation.)

Cliquer sur [**Continue installation**].

9. Le message **“The software was successfully installed”** s’affiche une fois l’installation du logiciel terminée.

Cliquer sur **[Restart]** pour redémarrer le Macintosh.

L’installation du pilote UM-3EX est terminée.

Procéder ensuite au paramétrage du périphérique MIDI. (→ **“Réglage du pilote”** (p. 84))

## ■ Réglage du pilote

Configuration de l’UM-3EX pour une utilisation avec un séquenceur logiciel et un paramétrage Macintosh standard.

Si le séquenceur n’exploite pas les paramètres Macintosh standard, le paramétrage doit être fait dans le séquenceur.

*\* Les données affichées à l’écran peuvent varier selon le type d’ordinateur et de système d’exploitation utilisé.*

1. Placer le **Operation of the UM-3EX** **sélecteur de MODE** de l’UM-3EX sur la position **MASTER**.

2. **Operation of the UM-3EX** Positionner le **Sélecteur du numéro d’UNITÉ** de l’UM-3EX sur 1.

3. **Operation of the UM-3EX** Ne connecter qu’un seul UM-3EX sur le Macintosh.

*\* Brancher le câble sur le connecteur USB du Macintosh lui-même, et non sur celui du clavier.*

*\* Cet appareil est équipé d’un circuit de protection. Une fois l’UM-3EX raccordé à l’ordinateur, laisser s’écouler quelques secondes avant de l’utiliser.*

4. Ouvrir le dossier **Applications** du disque dur du Macintosh. Dans le dossier **Utilities**, double-cliquer sur **Audio MIDI Setup** pour procéder au paramétrage.



5. Cliquer sur l’onglet **MIDI Devices**.

## 6. Vérifier que **1: UM-3** apparaît dans la boîte de dialogue **Audio MIDI Setup**.

- \* Le numéro "1:" au début du nom de périphérique est le numéro d'unité du UM-3EX. Ce numéro dépend de la position du sélecteur de numéro de l'unité.
- \* Si "**1: UM-3**" ne s'affiche pas ou apparaît en grisé, l'UM-3EX n'est pas correctement reconnu par l'ordinateur. Cliquer sur **Rescan MIDI**. On peut aussi débrancher, puis rebrancher l'UM-3EX.
- \* Il peut arriver que des paramètres liés à une version différente du pilote soient toujours installés. Si c'est le cas, cliquer sur le paramètre "**1: UM-3**" grisé pour le sélectionner, puis cliquer sur **Remove Selected Device** pour effacer les paramètres.

## 7. Cliquer trois fois sur **Add Device**.

Trois **nouveaux périphériques externes** s'affichent.

## 8. Attribuer un nom à chacun de ces **nouveaux périphériques externes**.

1. Cliquer sur le **nouveau périphérique externe** ajouté, puis sur **Show Info**.
2. Saisir le nom dans le champ **Device Name**.

|                                       |           |
|---------------------------------------|-----------|
| <b>Premier périphérique externe</b>   | 1: UM-3 1 |
| <b>Second périphérique externe</b>    | 1: UM-3 2 |
| <b>Troisième périphérique externe</b> | 1: UM-3 3 |



- \* Introduire le numéro d'unité de l'UM-3EX comme premier numéro "1:".

9. À l'aide de la souris, déplacer les symboles ▼ et ▲ correspondant aux entrées et sorties de l'icône 1: UM-3 et sur les icônes des **nouveaux périphériques externes** pour les connecter comme suit.

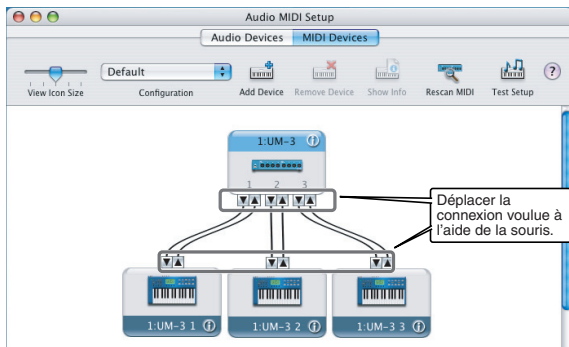

**10. Avec Mac OS X v10.2:**

Fermer la fenêtre **Audio MIDI Setup**. Le paramétrage est terminé.

**Avec Mac OS X v10.3 ou version ultérieure:**

Confirmer la bonne transmission et réception MIDI. Exécuter les étapes 11 à 14 (p. 87).

## 11. Cliquer sur **Test Setup**.

Le curseur de la souris change de forme 🎵.

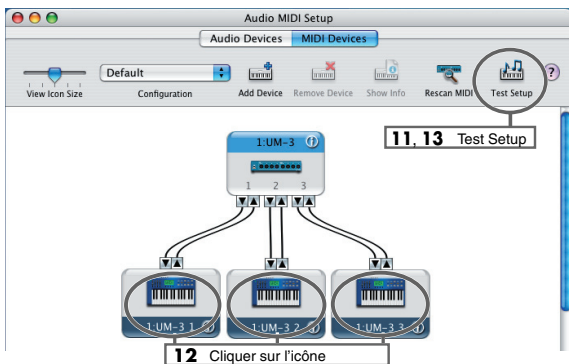

**12.** Cliquer sur la zone indiquée dans l'illustration. Si le témoin MIDI OUT correspondant de l'UM-3EX clignote, cela veut dire que le paramétrage est correct.

**13.** Cliquer sur **Test Setup** et terminer la confirmation.

**14.** Fermer la fenêtre **Audio MIDI Setup**.

### Utilisation de l'UM-3EX avec le séquenceur logiciel

Avant d'utiliser l'UM-3EX avec un séquenceur logiciel, prendre en compte les points suivants.

- Raccorder l'UM-3EX à l'ordinateur avant de lancer le logiciel.
- Ne pas déconnecter l'UM-3EX pendant que le logiciel fonctionne.  
Fermer le logiciel avant de déconnecter l'UM-3EX.
- L'UM-3EX ne fonctionne pas sous l'environnement Mac OS X Classic. N'utiliser l'UM-3EX que lorsque l'environnement Classic est inactif.

## Connexion de plusieurs unités UM-3EX

Les utilisateurs de Windows XP ou Mac OS X peuvent connecter simultanément jusqu'à trois unités UM-3EX sur un seul ordinateur via USB. En fonction du système utilisé, la seconde unité ou l'unité suivante ne sera peut-être pas utilisable. Cela dépend des limites imposées par la vitesse de l'unité centrale, le disque dur, la mémoire et les performances de votre logiciel.

\* *Seuls Windows XP et Mac OS X prennent en charge la connexion d'unités multiples.*

### ■ Numéro de l'UNITÉ

Lorsque plusieurs unités UM-2EX sont connectées, le sélecteur doit définir correctement le numéro de chacune. Sélectionner un numéro d'UNITÉ différent pour chaque UM-3EX.

Le numéro de l'UNITÉ est identifié par un "1:" ou "2:", etc. au début du nom du périphérique MIDI. L'indication "1:" ou "2:" dépendra du réglage du sélecteur du numéro de l'UNITÉ.

### ■ Connexion de trois unités UM-3EX

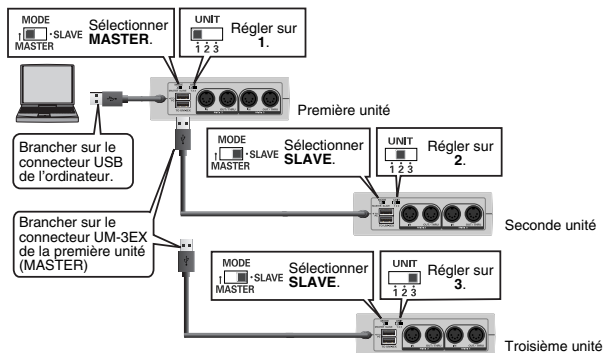



## Réglage du sélecteur de MODE et du sélecteur de numéro d'UNITÉ

|                                    |   |
|------------------------------------|---|
| <b>Sélecteur de MODE</b>           | <ul style="list-style-type: none"><li>• Sélectionner le paramètre <b>MASTER</b> pour l'unité UM-3EX connectée à l'ordinateur.</li><li>• Sélectionner le paramètre <b>SLAVE</b> pour les unités UM-3EX branchées sur le connecteur UM-3EX.</li></ul> |
| <b>Sélecteur du numéro d'UNITÉ</b> | <ul style="list-style-type: none"><li>• Régler la première unité sur <b>1</b>.</li><li>• Régler la seconde unité sur <b>2</b>.</li><li>• Régler la troisième unité sur <b>3</b>.</li></ul>  |

\* Ne pas modifier la position du **sélecteur de MODE** ou le **Sélecteur du numéro d'UNITÉ** pendant que l'UM-3EX est connecté à l'ordinateur. Avant toute chose, débrancher l'UM-3EX de l'ordinateur. Il peut être reconnecté une fois la position du sélecteur modifiée.

Connexions formellement déconseillées:

### UM-3EX sur SLAVE et branché à l'ordinateur

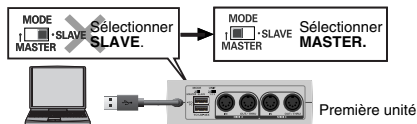

### UM-3EX sur MASTER et branché sur un connecteur UM-3EX

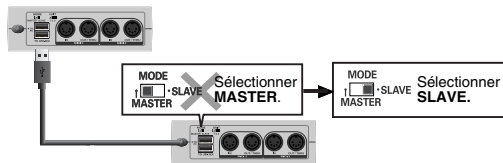

# Nomi e funzioni degli elementi

## Pannello frontale

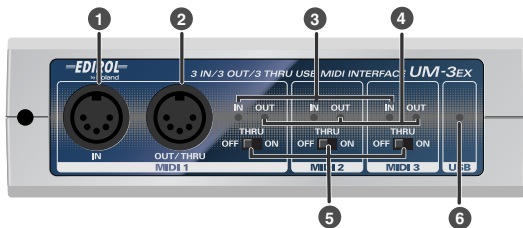

### 1 Connettori MIDI IN

Collegare ai connettori MIDI OUT dei dispositivi (ad esempio la tastiera MIDI) che trasmetteranno i messaggi MIDI al computer.

### 2 Connettori MIDI OUT/THRU

Collegare ai connettori MIDI IN dei moduli sonori o altri dispositivi ai quali verranno inviati i messaggi MIDI dal computer per la riproduzione.

### 3 Indicatori MIDI IN

Si illuminano quando i messaggi MIDI vengono ricevuti dai dispositivi collegati ai connettori MIDI IN.

### 4 Indicatori MIDI OUT

Si illuminano quando i messaggi MIDI sono trasmessi dal computer.

### 5 Interruttori THRU

Consentono di selezionare le destinazioni di uscita dei messaggi MIDI che arrivano dai dispositivi collegati ai connettori MIDI IN.

## ■ Impostazioni ON/OFF degli interruttori THRU

È possibile utilizzare gli **interruttori THRU** per selezionare le destinazioni di trasmissione per i messaggi MIDI dai dispositivi (tastiera MIDI, piano digitale, ecc...) collegati ai connettori MIDI IN. Non è necessario cambiare le connessioni dei cavi.

|                               |   |
|-------------------------------|---|
| <b>Interruttore THRU: OFF</b> | I messaggi MIDI che giungono dal connettore MIDI IN corrispondente sono inviati al computer (software sequencer). Normalmente viene utilizzato questa impostazione.                                     |
| <b>Interruttore THRU: ON</b>  | I messaggi MIDI che giungono dal connettore MIDI IN corrispondente sull'UM-3EX sono emessi dal connettore MIDI OUT/THRU corrispondente dell'UM-3EX. Attivarlo se non si utilizza il software sequencer. |

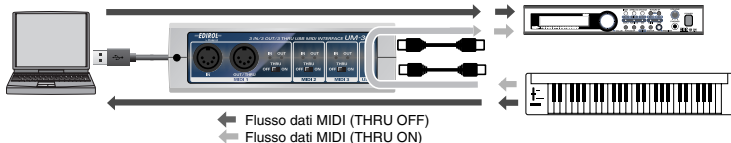

\* Non modificare le impostazioni di un **interruttore THRU** durante la riproduzione. Questo provocherebbe errori MIDI.

## 6 Indicatore USB

Si illumina quando si collega l'UM-3EX al computer e il computer lo rileva.

Perché il computer rilevi l'UM-3EX, è necessario installare il driver e configurare i parametri.

(→ "Collegamento e installazione dei driver (Windows)" (p. 94), "Collegamento e installazione dei driver (Macintosh)" (p. 98))

## Pannello posteriore

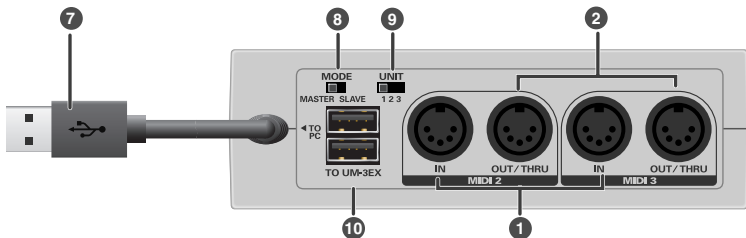

### 7 Cavo USB

Collegarlo al connettore USB del computer.

### 8 Interruttore di selezione modo (MODE)

L'UM-3EX può essere impostato per funzionare come dispositivo principale o come dispositivo secondario utilizzando questo interruttore.

|   |   |
|---|---|
| <b>Se si utilizza un'unica unità UM-3EX</b> | Selezionare l'impostazione <b>MASTER</b> se si utilizza un'unica unità UM-3EX.  |
| <b>Se si collegano diverse unità UM-3EX</b> | <ul style="list-style-type: none"><li>Selezionare l'impostazione <b>MASTER</b> per l'UM-3EX collegato al computer.</li><li>Selezionare l'impostazione <b>SLAVE</b> per le unità UM-3EX che sono collegate al connettore UM-3EX.</li></ul> |

\* Non modificare l'impostazione dell'interruttore di selezione MODE mentre l'UM-3EX è collegato al computer. Occorre prima scollegare l'UM-3EX dal computer. Ricollegarlo dopo aver modificato le impostazioni dell'interruttore.

\* La connessione di molteplici unità è supportata solo da Windows XP e Mac OS X. Per ulteriori informazioni, fare riferimento a "**Collegare più unità UM-3EX**" (p. 104).

## 9 Interruttore di selezione numero unità (UNIT)

Specifica il **numero unità** dell'UM-3EX.

Se si collegano più unità UM-3EX, è necessario impostare l'interruttore UNIT di ogni unità in modo opportuno. Impostare ogni UM-3EX su un numero UNIT diverso.

*\* Non modificare l'impostazione dell'interruttore di selezione UNIT mentre l'UM-3EX è collegato al computer. Occorre prima scollegare l'UM-3EX dal computer. Ricollegarlo dopo aver modificato le impostazioni dell'interruttore.*

## 10 Connettori UM-3EX

Utilizzarli se si collegano più unità UM-3EX.

*\* Non collegare nessun dispositivo diverso da UM-3EX al connettore UM-3EX. Questo potrebbe provocare un malfunzionamento dell'UM-3EX.*

# Collegamento e installazione dei driver (Windows)

## Prima di installare il driver

Procedura per l'installazione di un singolo UM-3EX.

Se si sta utilizzando Windows XP, è possibile collegare contemporaneamente fino a tre unità UM-3EX a un solo computer tramite USB.

- \* La connessione di più unità è supportata solo su Windows XP. Per ulteriori informazioni fare riferimento alla sezione **“Collegare più unità UM-3EX”** (p. 104).
- \* A seconda del sistema, la seconda unità o quella successiva potrebbero non essere utilizzabili in base alle limitazioni imposte da velocità di elaborazione della CPU, disco fisso, memoria e prestazioni del software.

### ■ Come procedere per realizzare la connessione

Impostare l'**interruttore di selezione MODE** e l'**interruttore di selezione UNIT** prima di collegare l'UM-3EX al computer.



|                                       |                               |
|---------------------------------------|-------------------------------|
| <b>Interruttore di selezione MODE</b> | Posizionarlo su <b>MASTER</b> |
| <b>Interruttore di selezione UNIT</b> | Posizionarlo su <b>1</b>      |

- \* Non modificare l'impostazione di **Interruttore di selezione MODE** o **Interruttore di selezione UNIT** mentre l'UM-3EX è collegato al computer. Occorre prima scollegare l'UM-3EX dal computer. Dopo aver cambiato le impostazioni degli interruttori, è possibile ricollegarlo al computer.

# Installazione del driver

## Definizione di un driver

Un **“driver”** è il software che trasferisce i dati tra l'UM-3EX e il programma utilizzato sul computer, quando il computer e l'UM-3EX sono collegati. Il driver trasmette i dati dall'applicazione all'UM-3EX e viceversa.

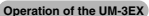
I passi da eseguire sull'UM-3EX stesso sono indicati con il simbolo  .

## Utenti Windows XP/2000

- 1 Avviare Windows con l'UM-3EX scollegato.  
Non collegare l'UM-3EX al computer fino al passo 14 ( p. 97).  
*\* Scollegare tutti i cavi USB, ad eccezione della tastiera e del mouse USB, se utilizzati.*  
*\* Accedere a Windows utilizzando un nome utente con privilegi amministrativi, ad esempio Administrator.*
- 2 Aprire la finestra di dialogo **System Properties** (Proprietà del sistema).

### Utenti Windows XP:

- 1 Dal menu di **avvio** di Windows scegliere **Pannello di controllo**.
- 2 In **“Pick a category”** (Scegliere una categoria), fare clic su **“Performance and Maintenance”** (Prestazioni e manutenzione).
- 3 In **“or pick a Control Panel icon”** (o un'icona del Pannello di controllo) fare clic sull'icona **System** (Sistema).  
A seconda della configurazione del sistema, l'icona **Sistema** potrebbe essere visualizzata direttamente nel **Pannello di controllo** (visualizzazione classica). In questo caso, fare doppio clic sull'icona **Sistema**.

### Utenti Windows 2000:

- 1 Dal menu di **avvio** di Windows scegliere **Impostazioni | Pannello di controllo**.
- 2 In **Pannello di controllo** fare doppio clic sull'icona **Sistema**.
- 3 Fare clic sulla scheda **Hardware** e quindi su **[Driver Signing]** (Firma driver).  
Verrà visualizzata la finestra di dialogo **Driver Signing Options** (Opzioni firma driver).
- 4 Nella finestra di dialogo **Driver Signing Options**, selezionare l'opzione **“Ignore”**, poi fare clic su **[OK]**.  
Se l'impostazione corrente è **“Warn”** (Avvisa) o **“Block”** (Blocca), cambiarla con **“Ignore”**. Al termine dell'installazione del driver, ripristinare l'impostazione originale.

- 5 Fare clic su **[OK]** per chiudere la finestra di dialogo **Proprietà del sistema**.
- 6 Chiudere tutti i programmi in esecuzione.  
Chiudere inoltre tutte le finestre aperte. Se si utilizza un antivirus o un programma simile, chiuderlo.
- 7 Preparare il CD-ROM.  
Inserire il CD-ROM nell'apposita unità del computer.
- \* *Se viene visualizzato il messaggio "Windows can perform the same action each time you insert a disk or connect a device with this kind of file" (È possibile eseguire la stessa operazione ogni volta che si inserisce un disco o che si commette una periferica con il seguente tipo di file) fare clic su **[Cancel]**.*
- 8 Scegliere **Esegui...** dal menu di **avvio** di Windows.
- 9 Nel campo **Apri** della finestra di dialogo **Esegui...** immettere la seguente stringa e quindi fare clic su **[OK]**.  
**D: \Driver\XP2k\Setup.exe**
- \* *L'identificativo dell'unità è **D**; nell'esempio qui riportato, ma potrebbe essere diverso sul sistema utilizzato. Utilizzare la lettera corrispondente all'unità CD-ROM in uso.*
- 10 Verrà visualizzata la finestra di dialogo **Driver Setup**.  
Fare clic su **[Next]**.
- 11 Per avviare l'installazione, fare di nuovo clic su **[Next]**. L'installazione avrà inizio.

#### **Utenti Windows XP:**

Se "**Driver Signing Options**" al passo 4 è impostato su "**Ignore**" verrà visualizzata una finestra di dialogo con il simbolo "**I**" o "**x**". Se viene visualizzato un pulsante **[Continue Anyway]**, fare clic su **[Continue Anyway]** per procedere con l'installazione. Se non è possibile continuare, fare clic su **[OK]** e ripetere l'installazione del driver dal passo 1.

#### **Utenti Windows 2000:**

Se "**Driver Signing Options**" al passo 4 è impostato su "**Ignore**" verrà visualizzata la finestra di dialogo "**Digital Signature Not Found**". Se viene visualizzato un pulsante **[Yes (S)]**, fare clic su **[Yes]** per procedere con l'installazione. Se non è possibile continuare, fare clic su **[OK]** e ripetere l'installazione del driver dal passo 1.

Verrà visualizzata la finestra di dialogo "**Setup is now ready to install the drivers**" (È ora possibile installare il driver).



- 12** **Operation of the UM-3EX** Impostare l'interruttore di selezione **MODE** dell'UM-3EX su **MASTER**.
- 13** **Operation of the UM-3EX** Impostare l'interruttore di selezione **UNIT** dell'UM-3EX su **1**.

- 14** **Operation of the UM-3EX** Collegare solo una UM-3EX al computer.

Viene visualizzato il messaggio "**Found New Hardware**" (Trovato nuovo hardware) Attendere.

\* *Questo apparecchio è provvisto di un circuito di protezione. È necessario attendere qualche secondo dopo aver collegato l'UM-3EX prima che l'apparecchio funzioni normalmente.*

#### **Utenti Windows XP:**

- 1** Appare la finestra di dialogo **Found New Hardware Wizard** (Installazione guidata nuovo hardware).  
Se viene visualizzato il messaggio "**Connect to Windows Update to search for software**" (Consentire la connessione a Windows Update per la ricerca di software?), scegliere "**No**" e quindi fare clic su **[Next]**.
- 2** Verificare che "**EDIROL UM-3**" sia visualizzato. Quindi scegliere "**Search for the best driver in these locations**" (Ricerca il miglior driver disponibile in questi percorsi) e fare clic su **[Next]**.

\* Se "**Driver Signing Options**" al passo 4 è impostato su "**Ignore**" verrà visualizzata una finestra di dialogo con il simbolo "**!**" Fare clic su **[Continue Anyway]** per procedere con l'installazione.

#### **Utenti Windows 2000:**

Se "**Driver Signing Options**" al passo 4 è impostato su "**Ignore**" verrà visualizzata la finestra di dialogo "**Digital Signature Not Found**". Fare clic su **[Yes]** per procedere con l'installazione.

- 15.** Verrà visualizzata la finestra di dialogo **Completing the Found New Hardware Wizard**.  
Fare clic su **[Finish]**.
- 16** Nella finestra di dialogo **Driver Setup** fare clic su **[Close]**.

Se viene visualizzata la finestra di dialogo **Change System Settings** (Modifica delle impostazioni di sistema), scegliere **[Yes]**. Windows verrà riavviato automaticamente.

\* *Se è stata modificata l'impostazione nella finestra "**Driver Signing Options**" al punto 4, ripristinare l'impostazione originale dopo il riavvio di Windows.*

# Collegamento e installazione dei driver (Macintosh)

## Prima di installare il driver

Procedura per l'installazione di un singolo UM-3EX.

Se si sta utilizzando Mac OS X, è possibile collegare contemporaneamente fino a tre unità UM-3EX a un solo Macintosh tramite USB.

- \* La connessione di molteplici unità è supportata solo su Mac OS X. Per ulteriori informazioni, fare riferimento a **“Collegare più unità UM-3EX”** (p. 104)
- \* A seconda del sistema, la seconda unità o quella successiva potrebbero non essere utilizzabili in base alle limitazioni imposte da velocità di elaborazione della CPU, disco fisso, memoria e prestazioni del software.

### ■ Come procedere per realizzare la connessione

Impostare l'interruttore di selezione **MODE** e l'interruttore di selezione **UNIT** prima di collegare l'UM-3EX al Macintosh.



|                                       |                               |
|---------------------------------------|-------------------------------|
| <b>Interruttore di selezione MODE</b> | Posizionarlo su <b>MASTER</b> |
| <b>Interruttore di selezione UNIT</b> | Posizionarlo su <b>1</b>      |

- \* Non modificare l'impostazione di **Interruttore di selezione MODE** o **Interruttore di selezione UNIT** mentre l'UM-3EX è collegato al computer. Si deve prima scollegare l'UM-3EX dal Macintosh. Dopo aver cambiato le impostazioni degli interruttori, è possibile ricollegarlo al Macintosh.

# Installazione e configurazione del driver

## Definizione di un driver

Un **“driver”** è il software che trasferisce i dati tra l'UM-3EX e il programma utilizzato sul Macintosh, quando il Macintosh e l'UM-3EX sono collegati. Il driver trasmette i dati dall'applicazione all'UM-3EX e viceversa.

I passi da eseguire sull'UM-3EX stesso sono indicati con il simbolo **Operation of the UM-3EX**.

## Utenti Mac OS X

### ■ Installazione del driver

\* *Se durante l'installazione viene visualizzata la finestra di dialogo **“Authenticate”** (Autentica), inserire la password e fare clic su **“OK”**.*

\* *La schermata visualizzata potrebbe variare a seconda dell'ambiente e del sistema operativo installato.*

**1** Avviare Macintosh con l'UM-3EX scollegato.

\* *Scollegare tutti i cavi USB ad eccezione di quelli della tastiera e del mouse e riavviare il Macintosh.*

**2** Chiudere tutti i programmi in esecuzione.

**3** Preparare il CD-ROM.

Inserire il CD-ROM nell'apposita unità del Macintosh.

**4** Nella cartella **Driver (Mac OS X)** del CD-ROM, fare doppio clic su **UM3USBDriver.pkg**.

È possibile che venga visualizzato un messaggio simile a **“This Installer package needs to...”**

Fare clic su **“Continue”**.

**5** Sullo schermo verrà visualizzato il seguente messaggio: **“Welcome to the EDIROL UM-3Driver Installer”**

Fare clic su **[Continue]**.

**6** Sullo schermo verrà visualizzato il seguente messaggio: **“Select a Destination”**.

Selezionare l'unità in cui è installato il sistema operativo e fare clic su **[Continue]**.

\* *Selezionare il disco di avvio come unità.*

**7** Verrà visualizzato il messaggio **“Easy Install”** (Installazione standard).

Fare clic su **[Install]** o **[Upgrade]**.

**8** Verrà visualizzato il seguente messaggio: **“Installing this software requires you to restart your computer when the installation is done”** (Dopo aver installato questo software è necessario riavviare il computer).

Fare clic su **[Continue Installation]**.

9 Verrà visualizzato il seguente messaggio **“The software was successfully installed”** (Il software è stato installato in modo corretto).

Fare clic su **[Restart]** per riavviare il Macintosh.

L'installazione del driver UM-3EX è giunta al termine.

Successivamente, configurare il dispositivo MIDI. (→**“Configurazione del driver”** (p. 100))

## ■ Configurazione del driver

Di seguito vengono descritte le impostazioni che abilitano l'uso dell'UM-3EX con il software sequencer utilizzando le impostazioni standard di Macintosh.

Se si utilizza un software sequencer che non utilizza le impostazioni standard di Macintosh, eseguire le impostazioni contenute nel software sequencer.

\* La schermata visualizzata potrebbe variare a seconda dell'ambiente e del sistema operativo installato.

1 **Operation of the UM-3EX** Impostare l'**interruttore di selezione MODE** dell'UM-3EX su **MASTER**.

2 **Operation of the UM-3EX** Impostare l'**interruttore di selezione UNIT** dell'UM-3EX su **1**.

3 **Operation of the UM-3EX** Collegare solo una UM-3EX a Macintosh.

\* Collegare il cavo al connettore USB del Macintosh, non a quello della tastiera.

\* Questo apparecchio è provvisto di un circuito di protezione. È necessario attendere qualche secondo dopo aver collegato l'UM-3EX prima che l'apparecchio funzioni normalmente.

4 Aprire la cartella **Applications** del disco fisso del Macintosh. Nella cartella **Utilities** fare doppio clic su **Audio MIDI Setup** per aprire la finestra di dialogo **Audio MIDI Setup**.



5 Fare clic sulla scheda **MIDI Devices**.

**6** Verificare che **1: UM-3** viene visualizzato nella finestra di dialogo **Audio MIDI Setup**.

- \* Il numero "1:" davanti al nome del dispositivo corrisponde al numero dell'unità dell'UM-3EX. Questo valore dipende dalle impostazioni dell'interruttore di selezione UNIT.
- \* Se "1: UM-3 non viene visualizzato o se non è attivo, significa che l'UM-3EX non è stato riconosciuto in modo corretto. Fare clic su **Rescan MIDI**. Scollegare e ricollegare l'UM-3EX.
- \* Potrebbero essere presenti impostazioni che appartengono a un'installazione precedente che appartengono a una versione del driver diversa. In tal caso, fare clic su "1: UM-3" per selezionarlo, e fare clic su **Remove Selected Device** (Rimuovere il dispositivo selezionato) per cancellare le impostazioni.

**7** Fare clic tre volte su **Add Device** (Aggiungi dispositivo).

Compaiono tre **nuovi dispositivi esterni**.

**8** Immettere un **nome** per ogni **nuovo dispositivo esterno**.

- 1 Fare clic sul **nuovo dispositivo esterno** aggiunto, poi fare clic su **Show Info** (Mostra informazioni).
- 2 Immettere il nome nel campo **Device Name** (Nome dispositivo).

|                                    |           |
|------------------------------------|-----------|
| <b>Primo dispositivo esterno</b>   | 1: UM-3 1 |
| <b>Secondo dispositivo esterno</b> | 1: UM-3 2 |
| <b>Terzo dispositivo esterno</b>   | 1: UM-3 3 |



- \* Inserire il numero UNITÀ dell'UM-3EX come primo numero "1:".

- 9 Utilizzare il mouse per trascinare i simboli ▼ e ▲ che indicano i segnali in ingresso e quelli in uscita dell'icona **1: UM-3** e delle icone **nuovo dispositivo esterno** in modo tale che risultino collegati come segue.

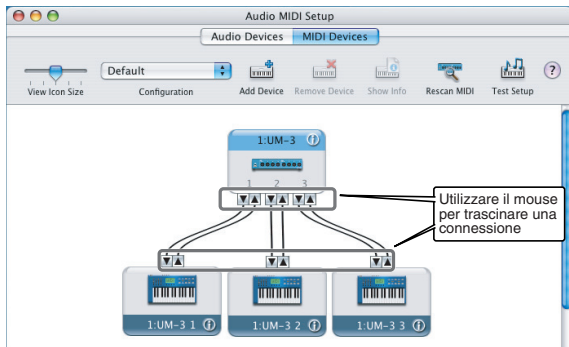

**10 Se si sta utilizzando Mac OS X v10.2:**

Chiudere la finestra di dialogo **Audio MIDI Setup**. La procedura di installazione è giunta al termine.

**Se si sta utilizzando Mac OS X v10.3 o superiori:**

Verificare che la trasmissione e la ricezione MIDI siano corrette. Eseguire le operazioni descritte dal punto 11 al 14 (p. 103).

- 11 Fare clic su **Test Setup**.  
La forma del cursore del mouse cambia .

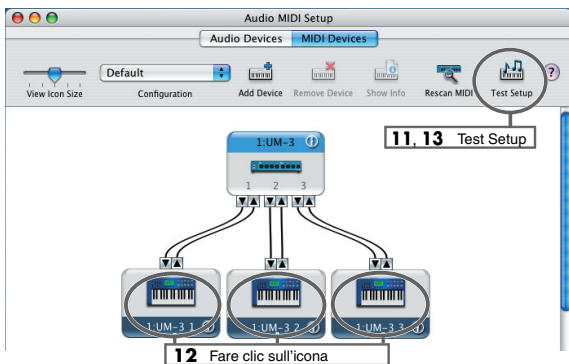

- 12 Fare clic sull'area raffigurata nell'immagine. Se l'indicatore MIDI OUT corrispondente dell'UM-3EX lampeggia, le impostazioni sono corrette.
- 13 Fare clic su **Test Setup** e completare la verifica.
- 14 Chiudere la finestra di dialogo **Audio MIDI Setup**.

#### **Se si utilizza l'UM-3EX con il software sequencer**

Prima di utilizzare l'UM-3EX con il software sequencer, leggere le seguenti indicazioni.

- Collegare l'UM-3EX al Macintosh prima di avviare il software sequencer.
- Non scollegare l'UM-3EX dal Macintosh mentre il software sequencer è in esecuzione. Chiudere il software sequencer prima di scollegare l'UM-3EX dal Macintosh.
- L'UM-3EX non funziona in ambiente Classic Mac OS X. Utilizzare l'UM-3EX quando l'ambiente Classic non è in esecuzione.

## Collegare più unità UM-3EX

Se si sta utilizzando Windows XP o Mac OS X, è possibile collegare contemporaneamente fino a tre unità UM-3EX a un solo computer tramite USB. A seconda del sistema, la seconda unità o quella successiva potrebbero non essere utilizzabili in base alle limitazioni imposte da velocità di elaborazione della CPU, disco fisso, memoria e prestazioni del software.

\* La connessione di più unità è supportata solo su Windows XP e Mac OS X.

### ■ Numero UNITÀ

Se si collegano più unità UM-3EX, è necessario impostare l'interruttore UNIT di ogni unità in modo opportuno. Impostare ogni UM-3EX su un numero UNIT diverso.

Il numero UNITÀ viene mostrato come "1:" o "2:" ecc... davanti al nome del dispositivo MIDI.

Il valore di "1:" o "2:" dipende dalle impostazioni dell'interruttore di selezione UNIT.

### ■ Collegare tre unità UM-3EX

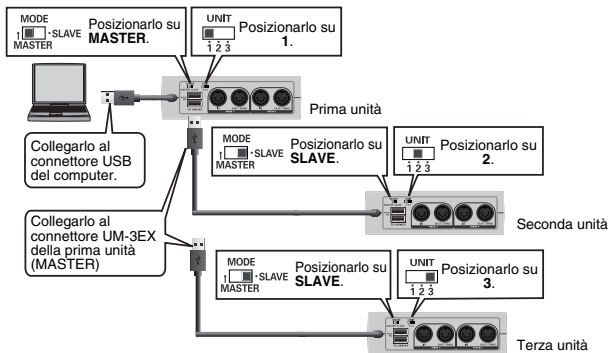



## Impostazioni degli interruttori di selezione **MODE** e **UNIT**

|  |   |
|--|---|
| <b>Interruttore di selezione <b>MODE</b></b> | <ul style="list-style-type: none"><li>• Selezionare l'impostazione <b>MASTER</b> per l'UM-3EX collegato al computer.</li><li>• Selezionare l'impostazione <b>SLAVE</b> per le unità UM-3EX che sono collegate al connettore UM-3EX.</li></ul> |
| <b>Interruttore di selezione <b>UNIT</b></b> | <ul style="list-style-type: none"><li>• Impostare la prima unità su <b>1</b>.</li><li>• Impostare la seconda unità su <b>2</b>.</li><li>• Impostare la terza unità su <b>3</b>.</li></ul>   |

\* Non modificare l'impostazione del **Interruttore di selezione **MODE**** o **Interruttore di selezione **UNIT**** mentre l'UM-3EX è collegato al computer. Occorre prima scollegare l'UM-3EX dal computer. Dopo aver cambiato le impostazioni degli interruttori, è possibile ricollegarlo al computer.

Non realizzare connessioni come quelle che seguono.

### UM-3EX impostato su **SLAVE** e collegato a un computer

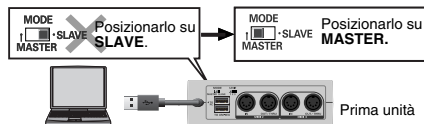

### UM-3EX impostato su **MASTER** e collegato al connettore UM-3EX

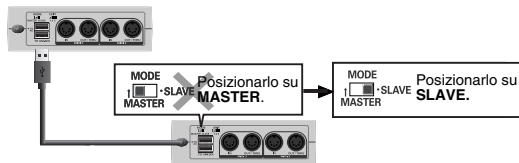

# Nombres de los diferentes elementos y sus funciones

## Panel frontal

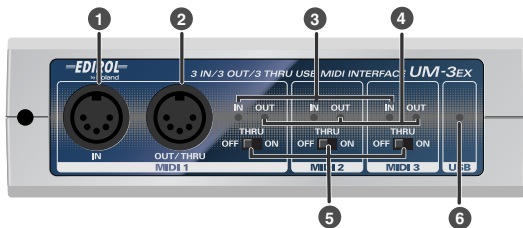

### 1 Conectores de entrada MIDI (MIDI IN)

Conéctelos a los conectores de salida MIDI (MIDI OUT) de los dispositivos (como un teclado MIDI) que transmitirán mensajes MIDI a su PC.

### 2 Conectores de salida MIDI/transmisión (MIDI OUT/THRU)

Conéctelos a los conectores MIDI IN (entrada MIDI) de los módulos de sonido u otros dispositivos a los que enviará mensajes MIDI desde el PC para su reproducción.

### 3 Indicadores de entrada MIDI (MIDI IN)

Se encienden cuando se reciben mensajes MIDI de dispositivos conectados a los conectores MIDI IN (entrada MIDI).

### 4 Indicadores de salida MIDI (MIDI OUT)

Se encienden cuando se transmiten mensajes MIDI desde el PC.

### 5 Interruptores de transmisión (THRU)

Le permiten seleccionar los destinos de salida de los mensajes MIDI que llegan de los dispositivos que ha conectado a los conectores MIDI IN (entrada MIDI).

## ■ Ajustes de activado/desactivado (ON/OFF) de los interruptores THRU (transmisión)

Puede utilizar los **interruptores THRU** (transmisión) para seleccionar los destinos de transmisión de los mensajes MIDI de los dispositivos (teclado MIDI, piano digital, etc.) conectados a los conectores MIDI IN (entrada MIDI). No es necesario cambiar ninguna conexión de cables.

|  |   |
|--|---|
| <b>Interruptor THRU (transmisión): OFF (desactivado)</b> | Los mensajes MIDI que llegan a través del conector MIDI IN (entrada MIDI) correspondiente se envían a su PC (software del secuenciador). Normalmente, deberá utilizar este ajuste.  |
| <b>Interruptor THRU (transmisión): ON (activado)</b>     | Los mensajes MIDI que llegan a través del conector MIDI IN (entrada MIDI) correspondiente de la unidad UM-3EX se envían del conector MIDI OUT/THRU (salida MIDI/transmisión) correspondiente de la UM-3EX. Actívelo si no utiliza el software del secuenciador. |

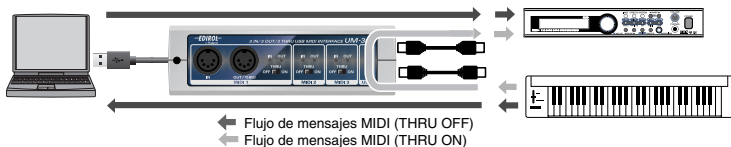

\* No cambie el ajuste de un **interruptor THRU** durante la reproducción. Si lo hace, se producirán errores de MIDI.

## 6 Indicador USB

Se encenderá cuando haya conectado la unidad UM-3EX al PC y éste haya detectado la UM-3EX. Para que el PC detecte la unidad UM-3EX, deberá instalar el controlador y realizar ajustes.

(→ "Conexión e instalación de los controladores (Windows)" (pág. 110), "Conexión e instalación de los controladores (Macintosh)" (pág. 114))

## Panel posterior

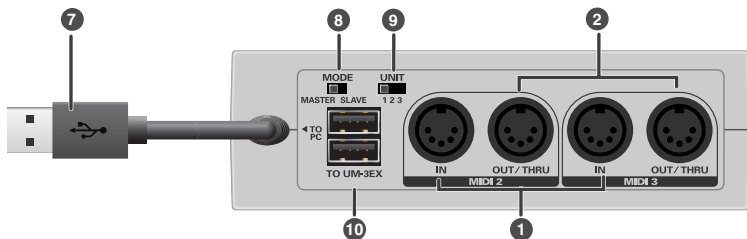

### 7 Cable USB

Conéctelo al conector USB del PC.

### 8 Interruptor de selección de modo (MODE)

La unidad UM-3EX puede ajustarse para funcionar como dispositivo maestro o dispositivo esclavo por medio de este interruptor.

|   |  |
|---|--|
| <b>Cuando utilice una única unidad UM-3EX</b>       | Seleccione el ajuste <b>MASTER</b> (maestro) si está utilizando una única unidad UM-3EX.   |
| <b>Cuando hay conectadas varias unidades UM-3EX</b> | <ul style="list-style-type: none"><li>• Seleccione el ajuste <b>MASTER</b> para la unidad UM-3EX que esté conectada al PC.</li><li>• Seleccione el ajuste <b>SLAVE</b> (esclavo) para las unidades UM-3EX que estén conectadas al conector de la UM-3EX.</li></ul> |

\* No cambie el ajuste del interruptor de selección **MODE** (modo) mientras la unidad UM-3EX esté conectada al PC. En primer lugar, deberá desconectar la unidad UM-3EX del PC. A continuación, una vez que haya cambiado el ajuste del interruptor, podrá volverlo a conectar.

\* La conexión de varias unidades sólo se admite con Windows XP y Mac OS X. Para obtener más detalles, consulte "**Conexión de varias unidades UM-3EX**" (pág. 120).

### 9 Interruptor de selección de número de unidad (UNIT)

Especifica el **número de unidad** (UNIT) de la UM-3EX.

Si conecta varias unidades UM-3EX, deberá establecer correctamente el ajuste de selección de número UNIT (unidad) de cada unidad. Ajuste cada unidad UM-3EX en un número UNIT (unidad) diferente.

*\* No cambie el ajuste del interruptor de selección de número UNIT mientras la UM-3EX esté conectada al PC. En primer lugar, deberá desconectar la unidad UM-3EX del PC. A continuación, una vez que haya cambiado el ajuste del interruptor, podrá volverlo a conectar.*

### 10 Conectores de UM-3EX

Utilícelos cuando conecte varias unidades UM-3EX.

*\* No conecte al conector de UM-3EX ningún otro dispositivo que no sea una unidad UM-3EX. Si lo hace, puede ocasionar que la unidad UM-3EX no funcione correctamente.*

# Conexión e instalación de los controladores (Windows)

## Antes de instalar el controlador

A continuación, se indica el procedimiento para instalar una única unidad UM-3EX.

Si utiliza Windows XP, puede conectar simultáneamente hasta tres unidades UM-3EX a un único PC a través de USB.

- \* La conexión de varias unidades sólo se admite en Windows XP. Para obtener más detalles, consulte **“Conexión de varias unidades UM-3EX”** (pág. 120).
- \* Dependiendo del sistema, es posible que la segunda unidad o la unidad siguiente no puedan utilizarse en función de las limitaciones impuestas por la velocidad de procesamiento de la CPU, el disco duro, la memoria y el rendimiento del software.

### ■ Precauciones de conexión

Ajuste el **interruptor de selección MODE (modo)** y el **interruptor de selección de número UNIT (unidad)** antes de conectar la unidad UM-3EX al PC.



|   |                             |
|---|-----------------------------|
| <b>Interruptor de selección MODE (modo)</b>             | Ajústelo en <b>MASTER</b> . |
| <b>Interruptor de selección de número UNIT (unidad)</b> | Ajústelo en <b>1</b> .      |

- \* No cambie el ajuste del **interruptor de selección MODE (modo)** o del **interruptor de selección de número UNIT (unidad)** mientras la unidad UM-3EX esté conectada al PC. En primer lugar, deberá desconectar la unidad UM-3EX del PC. A continuación, después de cambiar los ajustes de sus interruptores, podrá volver a conectar la unidad al PC.

# Instalación del controlador

## ¿Qué es un controlador?

Un “**controlador**” es software que transfiere datos entre la unidad UM-3EX y el software de aplicación que se esté ejecutando en su PC, cuando éste y la unidad UM-3EX estén conectados. El controlador envía datos de la aplicación a la unidad UM-3EX, y de la UM-3EX a la aplicación. Los pasos que deben realizarse en la propia unidad UM-3EX aparecen marcados con el símbolo

**Operation of the UM-3EX** .

## Usuarios de Windows XP/2000

1. Con la unidad UM-3EX desconectada, inicie Windows.  
No conecte la unidad UM-3EX al PC hasta que llegue al paso 14 (pág. 113).  
*\* Desconecte todos los cables USB excepto el del teclado USB y el ratón USB (si se utilizan).*  
*\* Inicie sesión en Windows con un nombre de usuario que tenga privilegios de administrador (como Administrador).*
2. Abra el cuadro de diálogo **Propiedades del sistema**.

### Usuarios de Windows XP:

1. Haga clic en el menú **Inicio** de Windows y seleccione **Panel de control**.
2. En “**Elija una categoría**”, haga clic en “**Rendimiento y mantenimiento**”.
3. En “**o elija un icono del Panel de control**”, haga clic en el icono **Sistema**.  
En función de la configuración, puede que el icono **Sistema** aparezca directamente en el **Panel de control** (en la Vista clásica). En este caso, haga doble clic en el icono **Sistema**.

### Usuarios de Windows 2000:

1. Haga clic en el menú **Inicio** de Windows y seleccione **Configuración** | **Panel de control**.
2. En el **Panel de control**, haga doble clic en el icono **Sistema**.
3. Haga clic en la ficha **Hardware** y, a continuación, en **[Firma de controladores]**.  
Aparecerá el cuadro de diálogo **Opciones de firma del controlador**.
4. En el cuadro de diálogo **Opciones de firma del controlador**, seleccione “**Ninguna**” y, a continuación, haga clic en **[Aceptar]**.  
Si la opción seleccionada es “**Advertir**” o “**Bloquear**”, cámbiela a “**Ninguna**”. A continuación, cuando haya acabado de instalar el controlador, vuelva a cambiarla a la opción original.

5. Haga clic en **[Aceptar]** para cerrar el cuadro de diálogo **Propiedades del sistema**.
6. Salga de todos los programas de software (aplicaciones) que esté ejecutando.  
Cierre todas las ventanas que estén abiertas. Si está utilizando un antivirus o software similar, deberá cerrar todos estos programas.
7. Prepare el CD-ROM.  
Inserte el CD-ROM en la unidad de CD-ROM de su PC.  
*\* Si aparece el mensaje “Windows puede realizar la misma acción cada vez que inserte un disco o conecte un dispositivo con este tipo de archivo”, haga clic en [Cancelar].*
8. En el menú **Inicio** de Windows, elija **Ejecutar...**
9. En el campo **Abrir** del cuadro de diálogo **Ejecutar...**, escriba lo siguiente y haga clic en **[Aceptar]**.  
**D: \Driver\XP2k\Setup.exe**  
*\* El nombre de la unidad es **D:** en el ejemplo descriptivo mostrado en esta página, pero puede ser otro en su sistema. Use el nombre de la unidad de CD-ROM.*
10. Aparecerá el cuadro de diálogo **Configuración del controlador**.  
Haga clic en **[Siguiente]**.
11. Para comenzar la instalación, haga clic en **[Siguiente]** de nuevo. Se iniciará la instalación.

#### **Usuarios de Windows XP:**

Si “**Opciones de firma del controlador**” en el paso 4 es cualquier valor que no sea “**Ninguna**”, aparecerá un cuadro de diálogo con el símbolo “**I**” o “**x**”. Si aparece un botón de **[Continuar]**, haga clic en **[Continuar]** para continuar con la instalación. Si no puede continuar, haga clic en **[Aceptar]** y repita la instalación del controlador desde el paso 1.

#### **Usuarios de Windows 2000:**

Si “**Opciones de firma del controlador**” en el paso 4 es cualquier valor que no sea “**Ninguna**”, aparecerá un cuadro de diálogo que indica “**Firma digital no encontrada**”. Si aparece un botón de **[Sí]**, haga clic en **[Sí]** para proseguir con la instalación. Si no puede continuar, haga clic en **[Aceptar]** y repita la instalación del controlador desde el paso 1.

Aparecerá el cuadro de diálogo “**El programa de instalación está preparado para instalar el controlador**”.



- 12.** **Operation of the UM-3EX** Ajuste el **interruptor de selección MODE** (modo) de la unidad UM-3EX en **MASTER** (maestro).
- 13.** **Operation of the UM-3EX** Ajuste el **interruptor de selección de número UNIT** (unidad) de la UM-3EX en **1**.
- 14.** **Operation of the UM-3EX** Conecte sólo una unidad UM-3EX al PC. Aparecerá un mensaje de **“Hardware nuevo encontrado”**. Espere.
- \* *Esta unidad está provista de un circuito de protección. Es necesario dejar pasar un pequeño intervalo (de unos segundos) después de conectar la unidad UM-3EX para que ésta funcione correctamente.*

### Usuarios de Windows XP:

- 1.** Aparecerá el cuadro de diálogo del **Asistente para hardware nuevo encontrado**. Si aparece el mensaje **“¿Conectar a Windows Update para buscar software?”**, elija **“No”** y a continuación haga clic en **[Siguiente]**.
- 2.** Asegúrese de que se indica **“EDIROL UM-3”**. A continuación, seleccione **“Buscar mejor controlador en estas ubicaciones”** y haga clic en **[Siguiente]**.

\* Si **“Opciones de firma del controlador”** en el paso 4 es cualquier valor que no sea **“Ninguna”**, aparecerá un cuadro de diálogo con el símbolo **“!”**. Haga clic en **[Continuar]** para proseguir con la instalación.

### Usuarios de Windows 2000:

Si **“Opciones de firma del controlador”** en el paso 4 es cualquier valor que no sea **“Ninguna”**, aparecerá un cuadro de diálogo que indica **“Firma digital no encontrada”**. Haga clic en **[Sí]** para proseguir con la instalación.

- 15.** Aparecerá el cuadro de diálogo **Finalización del Asistente para hardware nuevo encontrado**. Haga clic en **[Finalizar]**.
- 16.** En el cuadro de diálogo **Configuración del controlador**, haga clic en **[Cerrar]**.

Si aparece el cuadro de diálogo **Cambiar la configuración del sistema**, haga clic en **[Sí]**. Windows se reiniciará automáticamente.

\* *Si ha cambiado la configuración de **“Opciones de firma de controlador”** en el paso 4, restablezca la configuración original después de reiniciar Windows.*

# Conexión e instalación de los controladores (Macintosh)

## Antes de instalar el controlador

A continuación, se indica el procedimiento para instalar una única unidad UM-3EX.

Si utiliza Mac OS X, puede conectar simultáneamente hasta tres unidades UM-3EX a un único Macintosh a través de USB.

- \* La conexión de varias unidades sólo se admite en Mac OS X. Para obtener más detalles, consulte “**Conexión de varias unidades UM-3EX**” (pág. 120).
- \* Dependiendo del sistema, es posible que la segunda unidad o la unidad siguiente no puedan utilizarse en función de las limitaciones impuestas por la velocidad de procesamiento de la CPU, el disco duro, la memoria y el rendimiento del software.

### ■ Precauciones de conexión

**Ajuste el interruptor de selección MODE (modo) y el interruptor de selección de número UNIT (unidad) antes de conectar la unidad UM-3EX al Macintosh.**



|   |                             |
|---|-----------------------------|
| <b>Interruptor de selección MODE (modo)</b>             | Ajústelo en <b>MASTER</b> . |
| <b>Interruptor de selección de número UNIT (unidad)</b> | Ajústelo en <b>1</b> .      |

- \* No cambie el ajuste del **interruptor de selección MODE (modo)** o del **interruptor de selección de número UNIT (unidad)** mientras la unidad UM-3EX esté conectada al equipo. En primer lugar, deberá desconectar la unidad UM-3EX del Macintosh. A continuación, después de cambiar los ajustes de sus interruptores, podrá volver a conectar la unidad al Macintosh.

# Instalación del controlador y ajustes

## ¿Qué es un controlador?

Un “controlador” es software que transfiere datos entre la unidad UM-3EX y el software de aplicación que se esté ejecutando en su Macintosh, cuando éste y la unidad UM-3EX estén conectados. El controlador envía datos de la aplicación a la unidad UM-3EX, y de la UM-3EX a la aplicación. Los pasos que deben realizarse en la propia unidad UM-3EX aparecen marcados con el símbolo

**Operation of the UM-3EX** .

## Usuarios de Mac OS X

### ■ Instalación del controlador

\* Si aparece el cuadro de diálogo “**Authenticate**” (autenticar) durante la instalación, introduzca la contraseña y haga clic en “**OK**”.

\* En la pantalla del Macintosh podrá aparecer información diferente, en función de su entorno informático y del sistema operativo que esté utilizando.

**1.** Con la unidad UM-3EX desconectada, inicie el Macintosh.

\* Desconecte todos los cables USB, excepto los del teclado y el ratón, e inicie el sistema.

**2.** Salga de todos los programas de software (aplicaciones) que esté ejecutando.

**3.** Prepare el CD-ROM.

Inserte el CD-ROM en la unidad de CD-ROM del Macintosh.

**4.** En la carpeta **Driver (Mac OS X)** del CD-ROM, haga doble clic en **UM3USBDriver.pkg**.

Es posible que aparezca un mensaje parecido a “**El paquete del programa de instalación necesita...**”. Haga clic en “**Continuar**”.

**5.** Aparecerá el mensaje “**Welcome to the EDIROL UM-2Driver Installer**”.

Haga clic en [**Continue**] (continuar).

**6.** En la pantalla se indicará “**Select a Destination**” (seleccione un destino).

Haga clic para seleccionar la unidad en la que esté instalado el sistema operativo y, a continuación, haga clic en [**Continue**].

\* Seleccione el disco de inicio como unidad.

**7.** Si en la pantalla se indicará “**Easy Install**” (instalación sencilla).

Haga clic en [Install] (instalar) o [Upgrade] (actualizar).

- Aparecerá el mensaje **“Installing this software requires you to restart your computer when the installation is done”** (Para instalar este software deberá reiniciar el equipo en el que se realizó la instalación).  
Haga clic en **[Continue installation]** (continuar con la instalación).
- En la pantalla se indicará **“The software was successfully installed”** (El software se ha instalado correctamente).  
Haga clic en **[Restart]** (reiniciar) para reiniciar el Macintosh.

Con esto finaliza la instalación del controlador de la unidad UM-3EX.

Ahora, configure los dispositivos MIDI. (→“**Configuración del controlador**” (pág. 116))

## ■ Configuración del controlador

A continuación, se describen los ajustes que permiten el uso de la unidad UM-3EX con software del secuenciador mediante ajustes de dispositivos estándares de Macintosh.

Si está utilizando un software de secuenciador que no utilice los ajustes de dispositivo estándar de Macintosh, realice la configuración del dispositivo dentro del software del secuenciador.

\* *En la pantalla del Macintosh podrá aparecer información diferente, en función de su entorno informático y del sistema operativo que esté utilizando.*

- Operation of the UM-3EX** Ajuste el **interruptor de selección MODE** (modo) de la unidad UM-3EX en **MASTER** (maestro).
- Operation of the UM-3EX** Ajuste el **interruptor de selección de número UNIT** (unidad) de la unidad UM-3EX en **1**.
- Operation of the UM-3EX** Conecte sólo una unidad UM-3EX al Macintosh.  
\* *Conecte el cable al conector USB del propio Macintosh, no al conector USB del teclado.*  
\* *Esta unidad está provista de un circuito de protección. Es necesario dejar pasar un pequeño intervalo (de unos segundos) después de conectar la unidad UM-3EX para que ésta funcione correctamente.*
- Abra la carpeta **Applications** (aplicaciones) del disco duro del Macintosh. En la carpeta **Utilities** (utilidades), haga doble clic en **Audio MIDI Setup** (configuración MIDI de sonido) para abrir el cuadro de diálogo **Audio MIDI Setup**.



5. Haga clic en la ficha **MIDI Devices** (dispositivos MIDI).

6. Confirme que **1: UM-3** aparece en el cuadro de diálogo **Audio MIDI Setup**.

\* El número "1:" al principio del nombre del dispositivo es el número de unidad de la UM-3EX. Este valor dependerá del ajuste del interruptor de selección de número UNIT (unidad).

\* Si "1: **UM-3**" no aparece o si está resaltado en gris, significa que la unidad UM-3EX no se está reconociendo correctamente. Haga clic en **Rescan MIDI** (volver a examinar MIDI). Intente desconectar y volver a conectar la unidad UM-3EX.

\* Puede que permanezcan los ajustes anteriores de la instalación de una versión diferente del controlador. En ese caso, haga clic en "1: **UM-3**" que aparece resaltado para seleccionarlo y después, haga clic en **Remove Selected Device** (eliminar dispositivo seleccionado) para eliminar los ajustes.

7. Haga clic tres veces en **Add Device** (añadir dispositivo).

Aparecerán tres **dispositivos externos nuevos**.

8. Especifique el nombre de dispositivo de cada **dispositivo externo nuevo**.

1. Haga clic en el **dispositivo externo nuevo** que ha añadido y después, haga clic en **Show Info** (mostrar información).

2. Introduzca el nombre en el campo **Device Name** (nombre de dispositivo).

|                                    |           |
|------------------------------------|-----------|
| <b>Primer dispositivo externo</b>  | 1: UM-3 1 |
| <b>Segundo dispositivo externo</b> | 1: UM-3 2 |
| <b>Tercer dispositivo externo</b>  | 1: UM-3 3 |



\* Introduzca el número UNIT (unidad) de la UM-3EX como el primer número "1:."

9. Utilice el ratón para arrastrar los símbolos ▼ y ▲ que indican las entradas y salidas del icono **1: UM-3** y los iconos de **dispositivo externo nuevo** de tal forma que se conecten de la siguiente manera.

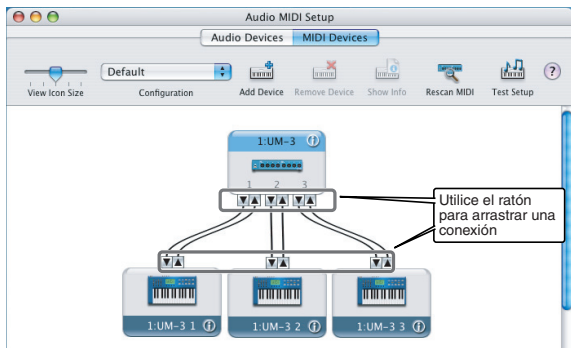

**10. Si se utiliza Mac OS X v10.2:**

Cierre el cuadro de diálogo **Audio MIDI Setup**. De este modo se completan los ajustes.

**Si utiliza Mac OS X v10.3 o una versión posterior:**

Confirme que MIDI se está transmitiendo y recibiendo correctamente. Realice los pasos 11–14 (pág. 119).

11. Haga clic en **Test Setup** (probar configuración)  
Cambia la forma del cursor del ratón 🎵.

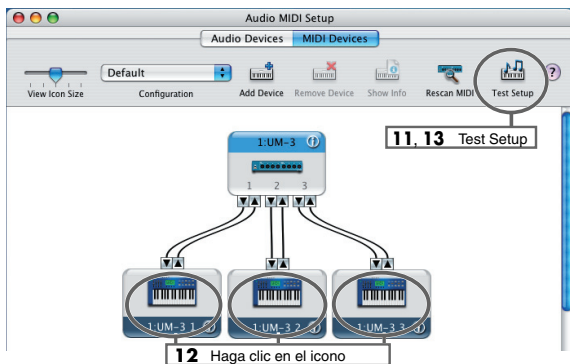

12. Haga clic en el área que se muestra en la ilustración. Si el indicador MIDI OUT (salida MIDI) correspondiente de la unidad UM-3EX parpadea, significa que los ajustes son correctos.
13. Haga clic en **Test Setup** y finalice la confirmación.
14. Cierre el cuadro de diálogo **Audio MIDI Setup**.

### Cuando utilice la unidad UM-3EX con su software de secuenciador

Antes de utilizar la unidad UM-3EX con su software de secuenciador, tenga en cuenta los siguientes puntos.

- Conecte la unidad UM-3EX al Macintosh antes de iniciar el software de secuenciador.
- No desconecte la unidad UM-3EX del Macintosh mientras se esté ejecutando el software del secuenciador.  
Salga del software del secuenciador antes de desconectar la unidad UM-3EX del Macintosh.
- La unidad UM-3EX no funcionará en el entorno Classic de Mac OS X. Utilice la unidad UM-3EX cuando no se esté ejecutando el entorno Classic.

## Conexión de varias unidades UM-3EX

Si utiliza Windows XP o Mac OS X, puede conectar simultáneamente hasta tres unidades UM-3EX a un único PC a través de USB. Dependiendo del sistema, es posible que la segunda unidad o la unidad siguiente no puedan utilizarse en función de las limitaciones impuestas por la velocidad de procesamiento de la CPU, el disco duro, la memoria y el rendimiento del software.

\* La conexión de varias unidades sólo se admite en Windows XP y Mac OS X.

### ■ Número UNIT (unidad)

Si conecta varias unidades UM-3EX, deberá establecer correctamente el ajuste de selección de número UNIT de cada unidad. Ajuste cada unidad UM-3EX en un número UNIT diferente.

El número UNIT se muestra como "1:" o "2:" etc. al principio del nombre del dispositivo MIDI.

El valor de la indicación "1:" o "2:" dependerá del ajuste del interruptor de selección de número UNIT.

### ■ Conexión de tres unidades UM-3EX

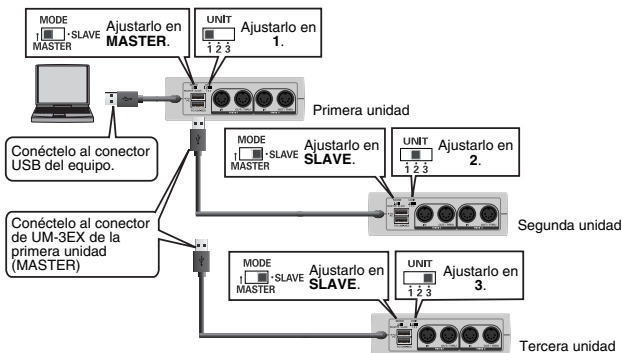



## Configuración de interruptor de selección **MODE (modo)** e interruptor de selección de número **UNIT (unidad)**

|  |  |
|--|--|
| <b>Interruptor de selección <b>MODE (modo)</b></b>             | <ul style="list-style-type: none"><li>• Seleccione el ajuste <b>MASTER</b> (maestro) para la unidad UM-3EX que esté conectada al PC.</li><li>• Seleccione el ajuste <b>SLAVE</b> (esclavo) para las unidades UM-3EX que estén conectadas al conector de la UM-3EX.</li></ul> |
| <b>Interruptor de selección de número <b>UNIT (unidad)</b></b> | <ul style="list-style-type: none"><li>• Ajuste la primera unidad en <b>1</b>.</li><li>• Ajuste la segunda unidad en <b>2</b>.</li><li>• Ajuste la tercera unidad en <b>3</b>.</li></ul>  |

\* No cambie el ajuste del **interruptor de selección **MODE (modo)**** o del **Interruptor de selección de número **UNIT (unidad)**** mientras la unidad UM-3EX esté conectada al PC. En primer lugar, deberá desconectar la unidad UM-3EX del PC. A continuación, después de cambiar los ajustes de sus interruptores, podrá volver a conectar la unidad al PC.

No realice conexiones como la siguiente.

### Unidad UM-3EX ajustada en **SLAVE (esclavo)** y conectada a un PC

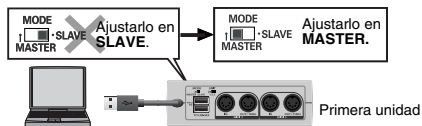

### Unidad UM-3EX ajustada en **MASTER (maestro)** y conectada a un conector de UM-3EX



# Index

|   |                   |
|---|-------------------|
| A   |                   |
| Add Device .....                          | 27                |
| B   |                   |
| Background Services .....                 | 18–19             |
| BUS Power .....                           | 48, 50            |
| C   |                   |
| Connecting multiple UM-3EX units .....    | 42                |
| D   |                   |
| Default device .....                      | 21                |
| driver .....                              | 15, 25            |
| Driver Signing Options .....              | 16                |
| duplicate notes .....                     | 38                |
| F   |                   |
| FreeMIDI .....                            | 30, 36            |
| L   |                   |
| Local Control OFF .....                   | 38                |
| M   |                   |
| MASTER .....                              | 12, 14            |
| MIDI Devices .....                        | 27                |
| MIDI IN Connector .....                   | 10                |
| MIDI IN Indicator .....                   | 10                |
| MIDI Music Playback .....                 | 21–22             |
| MIDI OUT Indicator .....                  | 10                |
| MIDI OUT/THRU Connector .....             | 10                |
| MODE select switch .....                  | 12, 14, 24, 44–45 |
| Multimedia Properties .....               | 23                |
| O   |                   |
| OMS .....                                 | 30, 32            |
| P   |                   |
| Performance Options .....                 | 19                |
| Preferred device .....                    | 22                |
| R   |                   |
| rack mount adaptor .....                  | 42                |
| RAF-70 .....                              | 42                |
| S   |                   |
| Single instrument .....                   | 23                |
| SLAVE .....                               | 12                |
| Sounds and Audio Devices Properties ..... | 21                |
| Sounds and Multimedia Properties .....    | 22                |
| System Properties .....                   | 15, 18            |
| T   |                   |
| Test Setup .....                          | 29                |
| THRU Switch .....                         | 10–11             |
| U   |                   |
| UNIT number select switch .....           | 13–14, 24, 44–45  |
| USB Cable .....                           | 12                |
| USB Indicator .....                       | 11                |

# Memo

# Information

When you need repair service, call your nearest EDIROL/Roland Service Center or authorized EDIROL/Roland distributor in your country as shown below.

## EDIROL

### EUROPE

**EDIROL (EUROPE) Ltd.**  
Studio 3.4 114 Power Road  
London W4 5PY  
U. K.

TEL: +44 (0)20 8747 5949  
FAX: +44 (0)20 8747 5948  
<http://www.edirol.com/europe>

### Deutschland

TEL: 0700 33 47 65 20

### France

TEL: 0810 000 371

### Italia

TEL: 02 93778329

## Roland

### NORTH AMERICA

### CANADA

**Roland Canada Music Ltd.**  
(Head Office)

5480 Parkwood Way Richmond  
B. C., V6V 2M4 CANADA  
TEL: (604) 270 6626

### U. S. A.

**Roland Corporation U.S.**  
5100 S. Eastern Avenue  
Los Angeles, CA 90040-2938,  
U. S. A.  
TEL: (323) 890 3700

### AFRICA

### EGYPT

Al Fanny Trading Office  
9, EBN Hagar Al Askalany  
Street,  
ARD El Golf, Heliopolis,  
Cairo 11341, EGYPT  
TEL: 20-2-417-1828

### REUNION

**Maison FO - YAM Marcel**  
25 Rue Jules Hermann,  
Chaudron - BP79 97 491  
Ste Clotilde Cedex,  
REUNION ISLAND  
TEL: (0262) 218-429

### SOUTH AFRICA

**Paul Bothner(PTY)Ltd.**  
Royal Cape Park, Unit 24  
Londonderry Road, Ottery 7800  
Cape Town, SOUTH AFRICA  
TEL: (021) 799 4900

### ASIA

### CHINA

**Roland Shanghai Electronics Co.,Ltd.**  
5F, No.150 Pingliang Road  
Shanghai 200090, CHINA  
TEL: (021) 5580-0800

**Roland Shanghai Electronics Co.,Ltd.**

(BEIJING OFFICE)  
10F, No.18 3 Section Anhuaxili  
Chaoyang District Beijing  
100011 CHINA  
TEL: (010) 6426-5050

**Roland Shanghai Electronics Co.,Ltd.**

(GUANGZHOU OFFICE)  
2/F, No.30 Si You Nan Er Jie  
Yi Xiang, Wu Yang Xin Cheng,  
Guangzhou 510600, CHINA  
TEL: (020) 8736-0428

### HONG KONG

**Parsons Music Ltd.**  
8th Floor, Railway Plaza, 39  
Chatham Road South, T.S.T.,  
Kowloon, HONG KONG  
TEL: 2333 1863

### INDIA

**Rivera Digitech (India) Pvt. Ltd.**  
409, Nirman Kendra  
Mahalaxmi Flats Compound  
Off. Dr. Edwin Moses Road,  
Mumbai-400011, INDIA  
TEL: (022) 2493 9051

### INDONESIA

**PT Citra IntiRama**  
Jl. Cideng Timur No. 15J-150  
Jakarta Pusat  
INDONESIA  
TEL: (021) 6324170

### KOREA

**Cosmos Corporation**  
1461-9, Seocho-Dong,  
Seocho Ku, Seoul, KOREA  
TEL: (02) 3486-8855

### MALAYSIA/ SINGAPORE

**Roland Asia Pacific Sdn. Bhd.**  
45-1, Block C2, Jalan PJU 1/39,  
Dataran Prima, 47301 Petaling  
Jaya, Selangor, MALAYSIA  
TEL: (03) 7805-3263

### PHILIPPINES

**G.A. Yupango & Co. Inc.**  
339 Gil J. Puyat Avenue  
Makati, Metro Manila 1200,  
PHILIPPINES  
TEL: (02) 899 9801

### TAIWAN

**ROLAND TAIWAN  
ENTERPRISE CO., LTD.**  
Room 5, 9fl. No. 112 Chung  
Shan N.Road Sec.2, Taipei,  
TAIWAN, R.O.C.  
TEL: (02) 2561 3339

### THAILAND

**Theera Music Co., Ltd.**  
330 Verng NakornKasem, Soi  
2, Bangkok 10100, THAILAND  
TEL: (02) 2248821

### VIETNAM

**SAIGON MUSIC  
DISTRIBUTOR  
(TAN DINH MUSIC)**  
138 Tran Quang Khai Street  
Dist. 1, Ho Chi Minh City  
VIETNAM  
TEL: (08) 848-4068

### AUSTRALIA/ NEW ZEALAND

### AUSTRALIA/ NEW ZEALAND

**Roland Corporation  
Australia Pty.,Ltd.**  
38 Campbell Avenue  
Dee Why West, NSW 2099  
AUSTRALIA

For Australia  
TEL: (02) 9982 8266  
For New Zealand  
TEL: (09) 3098 715

### CENTRAL/LATIN AMERICA

### ARGENTINA

**Instrumentos Musicales S.A.**  
Av.Santa Fe 2055  
(1123) Buenos Aires  
ARGENTINA  
TEL: (011) 4508-2700

### BARBADOS

**A&B Music Supplies Ltd**  
12 Webster Industrial Park  
Wildey, St.Michael, Barbados  
TEL: (246)430-1100

### BRAZIL

**Roland Brasil Ltda.**  
Rua San Jose, 780 Sala B  
Parque Industrial San Jose  
Cotia - Sao Paulo - SP, BRAZIL  
TEL: (011) 4615 5666

### CHILE

**Comercial Fanny II S.A.**  
Rut.: 96.919.420-1  
Nataliel Cox #739, 4th Floor  
Santiago - Centro, CHILE  
TEL: (02) 688-9540

### COLOMBIA

**Centro Musical Ltda.**  
Cra 43 B No 25 A 41 Bodegosa 9  
Medellin, Colombia  
TEL: (574)3812529

### CURACAO

**Zealandia Music Center Inc.**  
Orionweg 30  
Curacao, Netherland Antilles  
TEL:(305)5926866

### DOMINICAN REPUBLIC

**Instrumentos Fernando  
Giraldez**  
Calle Proyecto Central No.3  
Ens.La Esperilla  
Santo Domingo,  
Dominican Republic  
TEL:(809) 683 0305

### ECUADOR

**Mas Musica**  
Rumichaca 822 y Zaruma  
Guayaquil - Ecuador  
TEL:(593-4)2302364

### GUATEMALA

**Casa Instrumental**  
Calzada Roosevelt 34-01,zona 11  
Ciudad de Guatemala  
Guatemala  
TEL:(502) 599-2888

### HONDURAS

**Almaceo Pajaro AZUL S.A. de C.V.**  
BO.Paz Barahona  
3 Ave.11 Calle S.O  
San Pedro Sula, Honduras  
TEL: (504) 553-2029

### MARTINIQUE

**Musique & Son**  
Z.L.Les Mangle  
97232 Le Lamantin  
Martinique F.W.I.  
TEL: 596 596 426860

### Gigamusik SARL

10 Rte De La Folie  
97200 Fort De France  
Martinique F.W.I.  
TEL: 596 596 715222

### MEXICO

**Casa Vuerkamp, s.a. de cv.**  
Av. Toluca No. 323, Col.  
Olivar de los Padres 01780  
Mexico D.F. MEXICO  
TEL: (55) 5668-6699

### NICARAGUA

**Bansbach Instrumentos  
Musicales Nicaragua**  
Altamira D'Este Calle Principal de  
la Farmacia 5ta.Avenida  
1 Cuadra al Lago #503  
Managua, Nicaragua  
TEL: (505)277-2557

### PERU

**Audionet**  
Distribuciones Musicales SAC  
Juan Fanning 530  
Miraflores  
Lima - Peru  
TEL: (511) 4461388

## TRINIDAD

AMR Ltd  
Ground Floor  
Maritime Plaza  
Barataria Trinidad W.I.  
TEL: (868)638 6385

## URUGUAY

Todo Musica S.A.  
C.F.P. Acuna de Figueroa 1771  
C.P.: 11.800  
Montevideo, URUGUAY  
TEL: (02) 924-2335

## VENEZUELA

Instrumentos Musicales  
Allegro, C.A.  
Av. las industrias edf. Guitar  
import  
#7 zona Industrial de Turumo  
Caracas, Venezuela  
TEL: (212) 244-1122

## EUROPE

### AUSTRIA

Roland Elektronische  
Musikinstrumente HmbH.  
Austrian Office  
Eduard-Boehm-Gasse 8,  
A-6020 Innsbruck, AUSTRIA  
TEL: (0512) 26 44 260

### BELGIUM/FRANCE/ HOLLAND/ LUXEMBOURG

Roland Central Europe N.V.  
Houtstraat 3, B-2260, Oevel  
(Westerlo) BELGIUM  
TEL: (014) 575811

### CZECH REP.

K-AUDIO  
Kardasovska 626.  
CZ-198 00 Praha 9,  
CZECH REP.  
TEL: (2) 666 10529

### DENMARK

Roland Scandinavia A/S  
Nordhavnsvej 7, Postboks 880,  
DK-2100 Copenhagen  
DENMARK  
TEL: 3916 6200

## FINLAND

Roland Scandinavia As, Filial  
Finland  
Elanontie 5  
FIN-01510 Vantaa, FINLAND  
TEL: (09 68 24 020

## GERMANY

Roland Elektronische  
Musikinstrumente HmbH.  
Oststrasse 96, 22844  
Norderstedt, GERMANY  
TEL: (040) 52 60090

## GREECE

STOLLAS S.A.  
Music Sound Light  
155, New National Road  
Patras 26442, GREECE  
TEL: 2610 435400

## HUNGARY

Roland East Europe Ltd.  
Warehouse Area "DEPO" PE.83  
H-2046 Torokbalint,  
HUNGARY  
TEL: (23) 511011

## IRELAND

Roland Ireland  
G2 Calmount Park, Calmount  
Avenue, Dublin 12  
Republic of IRELAND  
TEL: (01) 4294444

## ITALY

Roland Italy S. p. a.  
Viale delle Industrie 8,  
20020 Arese, Milano, ITALY  
TEL: (02) 937-78300

## NORWAY

Roland Scandinavia Avd.  
Kontor Norge  
Lilleakerveien 2 Postboks 95  
Lilleaker N-0216 Oslo  
NORWAY  
TEL: 2273 0074

## POLAND

MX MUSICAL SP.Z.O.O.  
Ul. Gibraltarska 4.  
PL-03664 Warszawa POLAND  
TEL: (022) 679 44 19

## PORTUGAL

Roland Iberia, S.L.  
Portugal Office  
Cais das Pedras, 8/9-1 Dto  
4050-465, Porto, PORTUGAL  
TEL: 22 608 00 60

## ROMANIA

FBS LINES  
Piata Libertatii 1,  
535500 Gheorgheni,  
ROMANIA  
TEL: (266) 364 609

## RUSSIA

MuTek  
Dorozhnaya ul.3, korp.6  
117 545 Moscow, RUSSIA  
TEL: (095) 981-4967

## SPAIN

Roland Iberia, S.L.  
Paseo Garcia Faria, 33-35  
08005 Barcelona SPAIN  
TEL: 93 493 91 00

## SWEDEN

Roland Scandinavia A/S  
SWEDISH SALES OFFICE  
Danvik Center 28, 2 tr.  
S-131 30 Nacka SWEDEN  
TEL: (08) 702 00 20

## SWITZERLAND

Roland (Switzerland) AG  
Landstrasse 5, Postfach,  
CH-4452 Hingen,  
SWITZERLAND  
TEL: (061) 927-8383

## UKRAINE

TIC-TAC  
Mira Str. 19/108  
P.O. Box 180  
295400 Munkachevo,  
UKRAINE  
TEL: (03131) 414-40

## UNITED KINGDOM

Roland (U.K.) Ltd.  
Atlantic Close, Swansea  
Enterprise Park, SWANSEA  
SA7 9FJ,  
UNITED KINGDOM  
TEL: (01792) 702701

## MIDDLE EAST

### BAHRAIN

Badie Stores  
No.16, Bab Al Bahrain Avenue,  
P.O.Box 247, Manama 304,  
State of BAHRAIN  
TEL: 17 211 005

### CYPRUS

Radex Sound Equipment Ltd.  
17, Diagorou Street, Nicosia,  
CYPRUS  
TEL: (022) 66-9426

### IRAN

MOCO INC.  
No.41 Nike St., Dr.Shariyati Av.,  
Roberoye Cerah Mirdamad  
Tehran, IRAN  
TEL: (021) 285-4169

### ISRAEL

Halilit P. Greenspoon & Sons  
Ltd.  
8 Retzif Ha'aliya Hashnaya St.  
Tel-Aviv-Yafo ISRAEL  
TEL: (03) 6823666

### JORDAN

MUSIC HOUSE CO. LTD.  
FREDDY FOR MUSIC  
P. O. Box 922846  
Amman 11192 JORDAN  
TEL: (06) 5692696

### KUWAIT

EASA HUSAIN AL-YOUSIFI  
& SONS CO.  
Abdullah Salem Street,  
Safat, KUWAIT  
TEL: 243-6399

### LEBANON

Chahine S.A.L.  
Gerge Zeidan St., Chahine  
Bldg., Achrafieh, P.O.Box: 16-  
5857  
Beirut, LEBANON  
TEL: (01) 20-1441

## OMAN

TALENTZ CENTRE L.L.C.  
Malatan House No.11  
Al Noor Street, Ruwi  
SULTANATE OF OMAN  
TEL: 2478 3443

## QATAR

Badie Studio & Stores  
P.O. Box 62,  
Doha, QATAR  
TEL: 423554

## SAUDI ARABIA

aDawlah Universal  
Electronics APL  
Cormiche Road, Aldossary  
Bldg., 1st Floor, Alkhobar,  
SAUDI ARABIA

P.O.Box 2154, Alkhobar 31952  
SAUDI ARABIA  
TEL: (03) 898 2081

## SYRIA

Technical Light & Sound  
Center  
Rawda, Abdul Qader Jazairi St.  
Bldg. No. 21, P.O.BOX 13520,  
Damascus, SYRIA  
TEL: (011) 223-5384

## TURKEY

ZUHAL DIS TICARET A.S.  
Galip Dede Cad. No.37  
Beyoglu - Istanbul / TURKEY  
TEL: (0212) 249 85 10

## U.A.E.

Zak Electronics & Musical  
Instruments Co. L.L.C.  
Zabeel Road, Al Sherooq Bldg.,  
No. 14, Grand Floor, Dubai,  
U.A.E.  
TEL: (04) 3360715

As of December 1, 2005  
(EDIROL-1)

# Memo



This product complies with the requirements of European Directive 89/336/EEC.

For EU Countries

## FEDERAL COMMUNICATIONS COMMISSION RADIO FREQUENCY INTERFERENCE STATEMENT

For the USA

This equipment has been tested and found to comply with the limits for a Class B digital device, pursuant to Part 15 of the FCC Rules. These limits are designed to provide reasonable protection against harmful interference in a residential installation. This equipment generates, uses, and can radiate radio frequency energy and, if not installed and used in accordance with the instructions, may cause harmful interference to radio communications. However, there is no guarantee that interference will not occur in a particular installation. If this equipment does cause harmful interference to radio or television reception, which can be determined by turning the equipment off and on, the user is encouraged to try to correct the interference by one or more of the following measures:

- Reorient or relocate the receiving antenna.
- Increase the separation between the equipment and receiver.
- Connect the equipment into an outlet on a circuit different from that to which the receiver is connected.
- Consult the dealer or an experienced radio/TV technician for help.

This device complies with Part 15 of the FCC Rules. Operation is subject to the following two conditions:

- (1) This device may not cause harmful interference, and
- (2) This device must accept any interference received, including interference that may cause undesired operation.

Unauthorized changes or modification to this system can void the users authority to operate this equipment.  
This equipment requires shielded interface cables in order to meet FCC class B Limit.

For Canada

### NOTICE

This Class B digital apparatus meets all requirements of the Canadian Interference-Causing Equipment Regulations.

### AVIS

Cet appareil numérique de la classe B respecte toutes les exigences du Règlement sur le matériel brouilleur du Canada.

For the USA

## DECLARATION OF CONFORMITY Compliance Information Statement

Model Name : UM-3EX  
Type of Equipment : USB MIDI Interface  
Responsible Party : Roland Corporation U.S.  
Address : 5100 S. Eastern Avenue, Los Angeles, CA 90040-2938  
Telephone : (323) 890 3700

