

# TR-707/727

# SERVICE NOTES

First Edition

## SPECIFICATIONS

- Memory Capacity : 64 Rhythm Patterns (16 x 4 Group)
- Track : 4 (1 to 4; continuous Maximum measures=998)
- Step : 1 to 16 steps/measure
- Tempo :  $\text{♩} = 38$  to 250
  
- Rear Panel : Master Out (L,R/MONO) [8Vp-p, 1K $\Omega$ ]
- Trigger Out : +5V, 20ms Pulse TR-707 . . . . . Rim Shot  
TR-727 . . . . . Hi Agogo
  
- Sync In/Out (5P DIN): (1: Run/Stop, 2: GND, 3: Clock, 4: NC, 5: Continue)
- Power Consumption : 2.4 W
- Dimensions : 380 (W) x 73 (H) x 250 (D) mm  
14-15/16" (W) x 2-7/8" (H) x 9-13/16" (D) in
- Weight : 1.5 kg/13 lb. 5 oz.
- Accessories : 12V AC Adaptor  
Connection Cord PJ-1
- Options : Memory Cartridge M-64C  
Pedal Switch DP-2

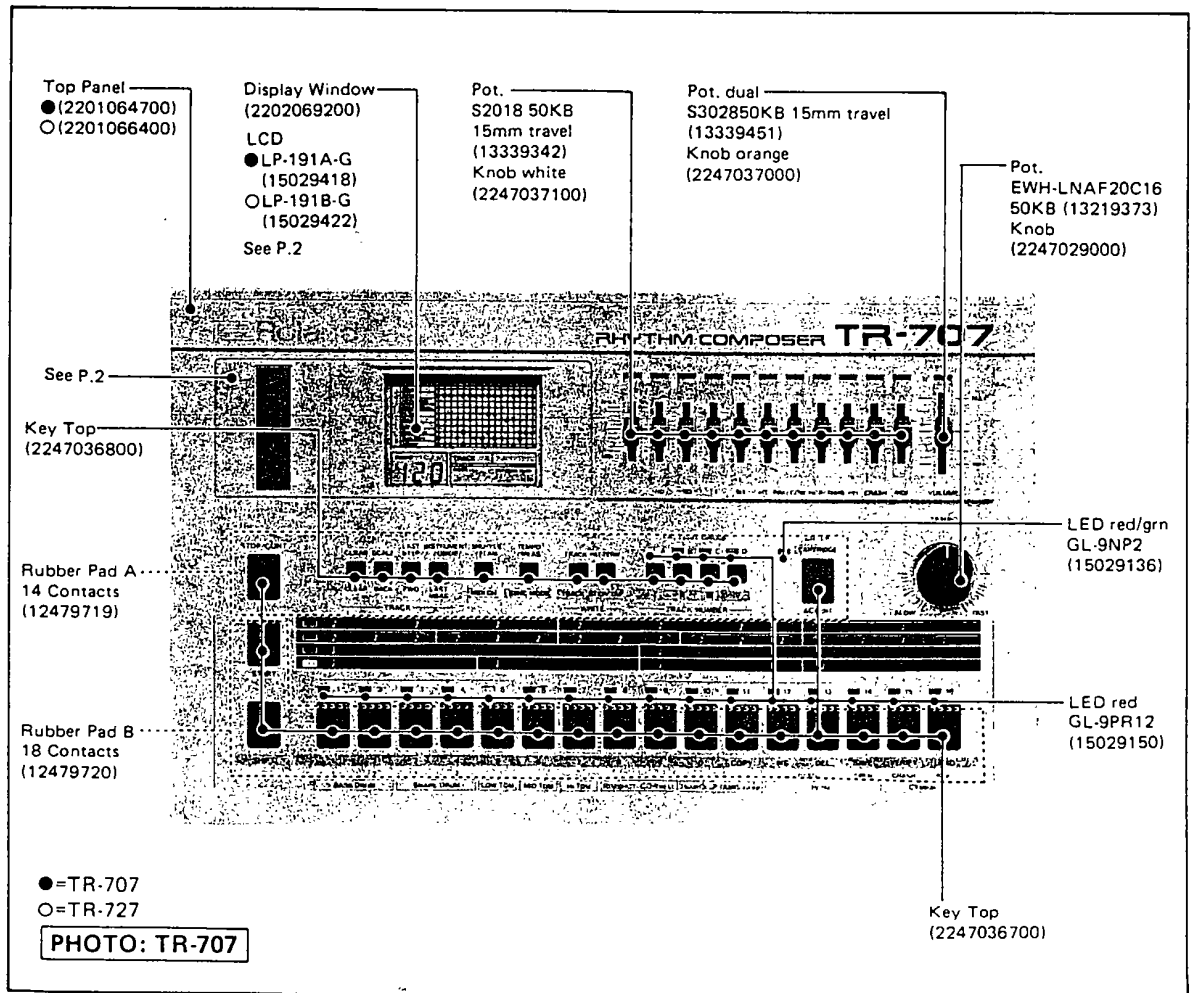

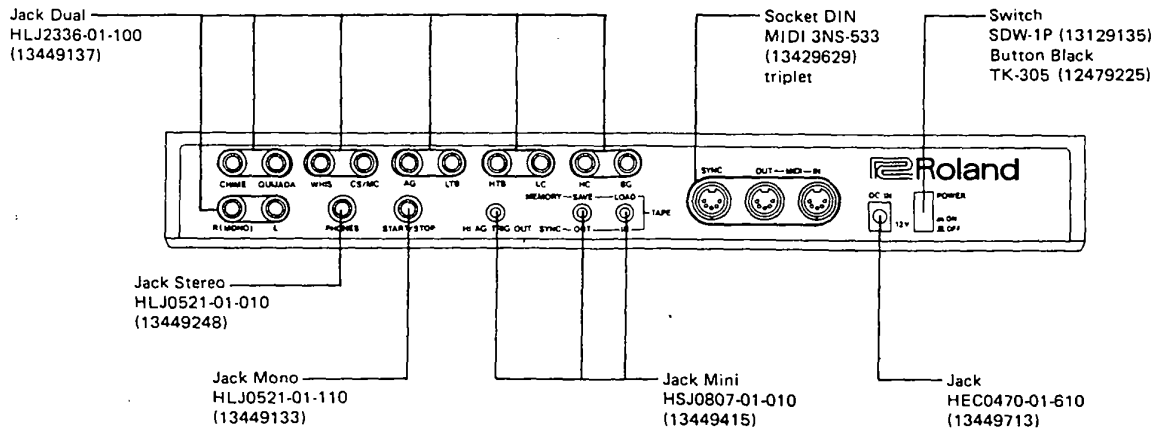

	TR-707	TR-727
<b>A</b>	Voicing Board (7313604000) (pcb 2291098102)	Voicing Board (7313804000) (pcb 2292018900)
<b>B</b>	Volume Board (7313605000) (pcb 2291098002)	Volume Board (7313805000) (pcb 2292019000)
<b>C</b>	Switch Board (7313606000) (pcb 2291097903)	
<b>D</b>	LCD Board (7313607000) (pcb 2291098203)	

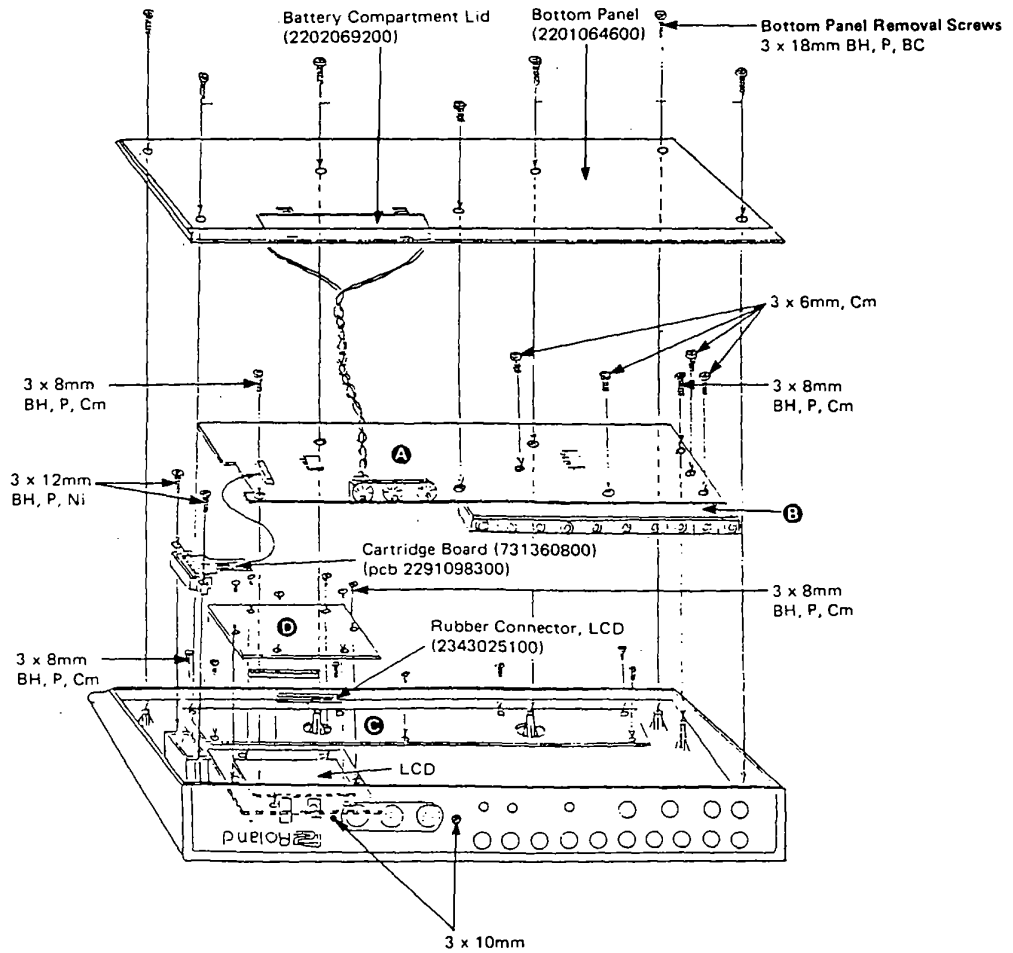

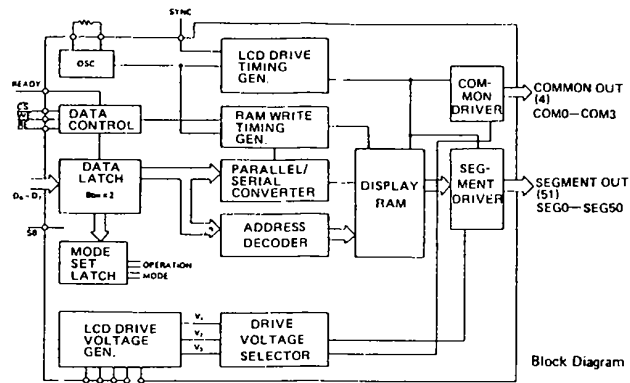

LCD Driver  
HD61602

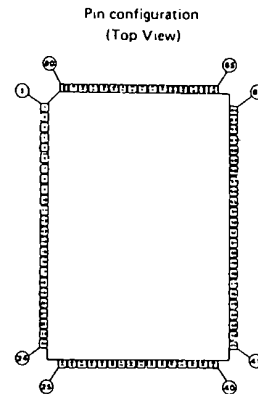

TERMINAL ASSIGNMENTS

Pin no.	Pin name	Pin no.	Pin name	Pin no.	Pin name
1	Vdd	26	OSC1	55	SEG27
2	READY	29	SEG18	56	SEG21
3	CS	30	SEG17	57	SEG19
4	FE	31	SEG16	58	STO19
5	FE	32	SEG15	59	SEG18
6	SB	33	SEG14	60	SEG17
7	D7	34	SEG13	61	SEG16
8	D6	35	SEG12	62	SEG15
9	D5	36	SEG11	63	SEG14
10	D4	37	SEG10	64	SEG13
11	Vdd	38	SEG9	65	SEG12
12	D3	39	SEG8	66	SEG11
13	D2	40	SEG7	67	SEG10
14	D1	41	SEG6	68	SEG9
15	D0	42	SEG5	69	SEG8
16	Free1	43	SEG4	70	SEG7
17	Free2	44	SEG3	71	SEG6
18	VEE	45	SEG2	72	SEG5
19	VEE	46	SEG1	73	SEG4
20	R1	47	SEG0	74	SEG3
21	R2	48	SEG75	75	SEG2
22	R3	49	SEG76	76	SEG1
23	COM0	50	SEG77	77	SEG0
24	COM1	51	SEG78	78	SYNC
25	COM2	52	SEG79	79	OSC2
26	COM3	53	SEG74	80	OSC1
27	SEG54	54	SEG73		

**PARTS LIST**  
**EXCLUSIVE PARTS**

**TR-707**

**CASING**

2201064700 Top Panel

**PCB**

7313604000 Voicing Board (pcb 2291098102)  
7313605000 Volume Board (pcb 2291098002)

**LCD**

15029418 LCD LP-191A-G

**IC**

**Program ROM**

15179720 HN4827128C-25 NMOS EPROM  
(Ver.0 SN460100-504399)  
(Ver.1 SN504400-519599)

or

15179660 HN613128PE95 CMOS MASK ROM  
(Ver.1 SN519600-533099)

or

15179692 HN613128PG24 CMOS MASK ROM  
(Ver.2 SN533100-up)

**UPWARD COMPATIBILITY**

Ver.0

In Pattern PLAY mode -- Selecting a pattern from different scale while repeating STOP and START or CONTINUE sometimes leads to Power-ON initialization.

ROMs of Ver. 1 always run the new pattern at the beginning of a measure.

Ver.1

When the unit is used as a Master -- Repetitions of STOP and CONTINUE more than 30 times would cause generation of a redundant MIDI clock \$F8.  
When the unit is used as a Slave -- Will miss a MIDI IN clock when STOP signal follows the Clock within 1ms.

MASK ROM of Ver.2 cures this problem.

For a replacement Ver.2 or up is recommendable.

上記コンパチなで補修用としてはバージョン番号の大きいPROMの使用が望ましい。

**Sound ROM**

15179661 HN61256PC-71 CMOS MASK ROM  
BD1/2, SD1/2, LT, MT  
15179662 HN61256PC-72 CMOS MASK ROM  
HT, Open/Closed H.H, Rim, Cow  
HCP, Tambourine  
15179663 HN61256PC-73 CMOS MASK ROM  
Crash Cymbal  
15179664 HN61256PC-74 CMOS MASK ROM  
Ride Cymbal

**TR-727**

**CASING**

2201066400 Top Panel

**PCB**

7313804000 Voicing Board (pcb 2292018900)  
7313805000 Volume Board (pcb 2292019000)

**LCD**

15029422 LCD LP-191B-G

**IC**

**Program ROM**

15179719 HN4827128C-25 NMOS EPROM

**Sound ROM**

15179694 HN61256PC-79 CMOS mask ROM  
HI/LOW BONGO, HI CONGA  
LOW CONGA, HI TIMBALE

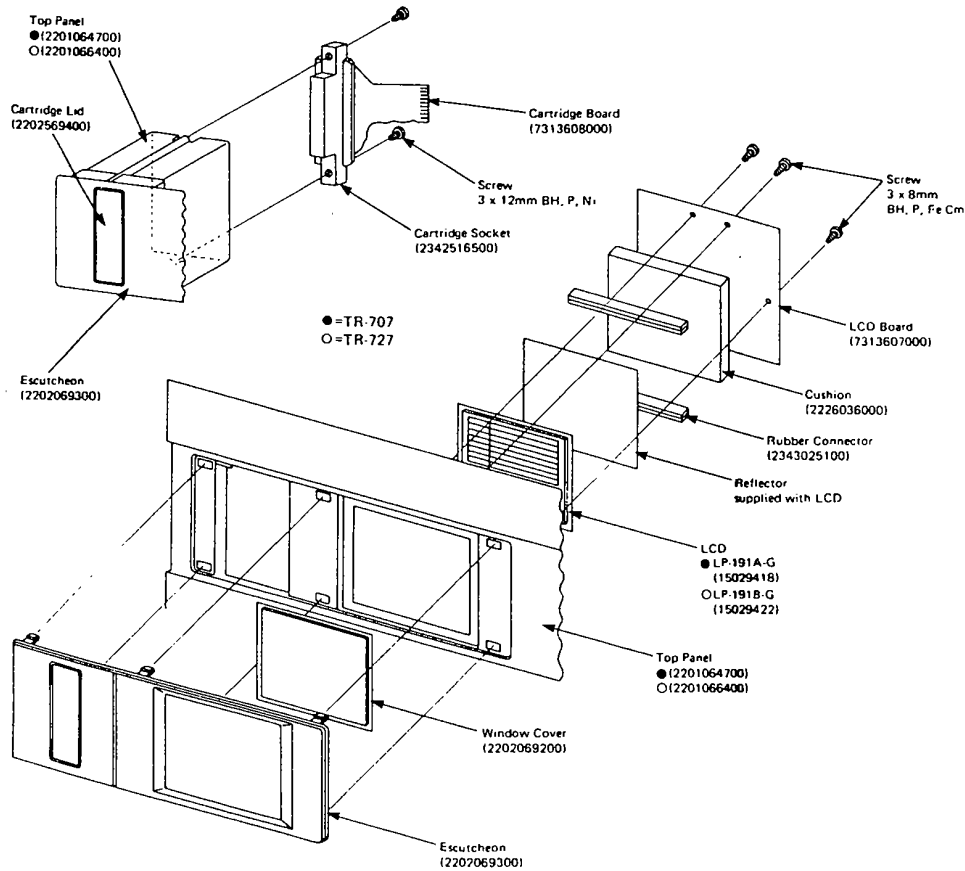

15179695	HN61256PC-80	CMOS mask ROM LON TIMBALE, AGOCO, CABASA MARACAS, WHISTLE
15179696	HN61256PC-81	CMOS mask ROM QULJADA
15179697	HN61256PC-82	CMOS mask ROM STAR CHIME

**COMMON PARTS**

**CASING**

2201064600	Bottom Case
2202069100	Battery Cover
2202069200	Display Window
2202069300	LCD Escutcheon
2202569400	Cartridge Lid

**KNOB, BUTTON, KEY TOP**

2247029000	Knob	gray	TEMPO
2247036700	Key Top (large)	gray	Main Key 1-16, ENTER, START, SHIFT, STOP/CONT
2247036800	Key Top (small)	gray	
2247037100	Knob	white	BD, SD, LT, MT, HT, OCH, RS/CB, HCP/TAMB, RIDE, CRASH
2247037000	Knob	orange	VOLUME
12479225	TK-305	black	POWER

**PCB ASSY**

7313606000	Switch Board	(pcb 2291097903)
7313607000	LCD Board	(pcb 2291098203)
7313608000	Cartridge Board	(pcb 2291098300)

**COIL, TRANSFORMER**

2244025000	S097744	Transformer	DC/DC converter
12449229	FKOB160MH15	Coil	line filter

**SOCKET**

13429629	MIDI 3-NS-533	DIN
13449713	HEC0470-01-610	AC adapter
13449415	HSJ0807-01-010	mini
13449248	HLJ0521-01-010	stereo
13449133	HLJ0521-01-110	monoral
13449137	HLJ2336-01-100	dual
2342516500	PBR5-28U-T01-S	cartridge

**SWITCH**

12479719	Rubber switch (Pad) A	14 contact upper row
12479720	Rubber switch (Pad) B	18 contact lower row
13129135	SDW-1P	POWER

**POTENTIOMETER**

13339342	S2018 50KB	slide 15mm travel
13339451	S3028 50KB	dual slide 15mm travel
13219373	EMH-LNAF20C16 50KB	TEMPO
13299136	RVF8P01-503 50KB	trimmer
13299141	RVF8P01-204 200KB	trimmer

**XTAL, CERAMIC RESONATOR**

12389736	HC-18/U	4.0MHz Xtal
12389735	CSA 1.6MK	1.6MHz ceramic resonator

**IC**

15229825	RD63H14PF	gate array
15179200	HD6303XF	CPU
15179340	HM6116LP-4	CMOS S RAM
15219148	HD61602	LCD driver
15159503	TC40H000P	H CMOS
15159504	TC40H002P	H CMOS
	quad 2-input NAND gate	
	quad 2-input NOR gate	

15159505	TC40H004P	H CMOS	hex inverter
15159517	TC40H010P	H CMOS	triple 3-input NAND gate
15159506	TC40H138P	H CMOS	3-to-8 line decoder/demultiplexer
15159535	TC40H151P	H CMOS	1-of-8 data selector/multiplexer
15159511	TC40H174P	H CMOS	hex D-type flip flop
15159524	TC40H245P	H CMOS	octal bidirectional bus buffer
15159507	TC40H273P	H CMOS	octal D-type flip flop
15159530	TC40H367P	H CMOS	hex bus buffer
15159104	TC40118P	CMOS	quad 2-input NAND gate
15159105	TC40138P	CMOS	dual D-type flip flop
15159141	HD14040BP	CMOS	12-stage binary counter
15159113	HD14051BP	CMOS	single 8-channel multiplexer/demultiplexer
15159301	TC45208P	CMOS	dual binary up counter
15159303	HD4584BP	CMOS	hex schmitt trigger
15189136	M5218L		Op amp
15189154	TL064		FET Op amp
15219147	UPC624C		D/A converter
15199108F0	UA78M05UC		voltage regulator +5V
15229712	PC900		photo coupler
15149118	M54517P		transistor array

**TRANSISTOR**

15129612	2SD1469-R	NPN
15129137	2SC2603-F	NPN
15129412	2SC1384-Q	NPN
15119125	2SA1115-F	PNP
15139101	2SK30ATH-Y	FET

**DIODE**

15019126	1SS113T-77	diode
15019209T0	S-5500G	rectifier
15019667	RD-12EB1-T	12V zener
15029136	GL-9NP2	LED red/grn
15029150	GL-9PR12	LED red

**RESISTOR ARRAY**

13919133	RKH7LM502	D/A converter
13919103	RGSDBX103J	10K x 8
13919113	RGSDBX103J	10K x 4
13910107	RSD8X332J	3.3K x 8

**CONNECTOR**

13439256	5089-11A	11P (Switch pcb)
13439255	5089-13A	13P (Switch pcb)
13439253	5494-9C	9P (Voicing pcb)
13439252	5494-10C	10P (Voicing pcb)
13439254	5597-28APB	28P (Voicing pcb) cartridge
2343025100		rubber connector LCD

**WIRING ASS'Y**

2341048000	13P	(LCD pcb)
2341047900	11P	(Voicing pcb)
2347015200	9P flat cable	(Volume pcb)
2347015300	10P flat cable	(Volume pcb)

**MISCELLANEOUS**

2217515300	Spring	RAM cartridge
2214531300	Shaft	RAM cartridge
2345014600	Plate	battery
12469117	Heat Sink MT-25-BS	(switch pcb)
2219049900	LED Holder	
13529117	Ceramic Capacitor D55Y5V1H334Z21	0.33uF (LCD pcb)
12559708	Fusing Resistor FRNB 1/4W2.7Ω	top panel
2225022801	Shield Cover	
2225022400	Shield	(Voicing pcb-Volume pcb)

**COMMERCIALLY AVAILABLE ACCESSORIES**

12569105	Dry cell SUM-35 1.5V	
12449538	12V AC adapter (100V)	
12449539	12V AC adapter (117V)	
12449540	12V AC adapter (220V)	
12449541	12V AC adapter (240VA)	Australian
2343067500	Connection Cable LP-25	

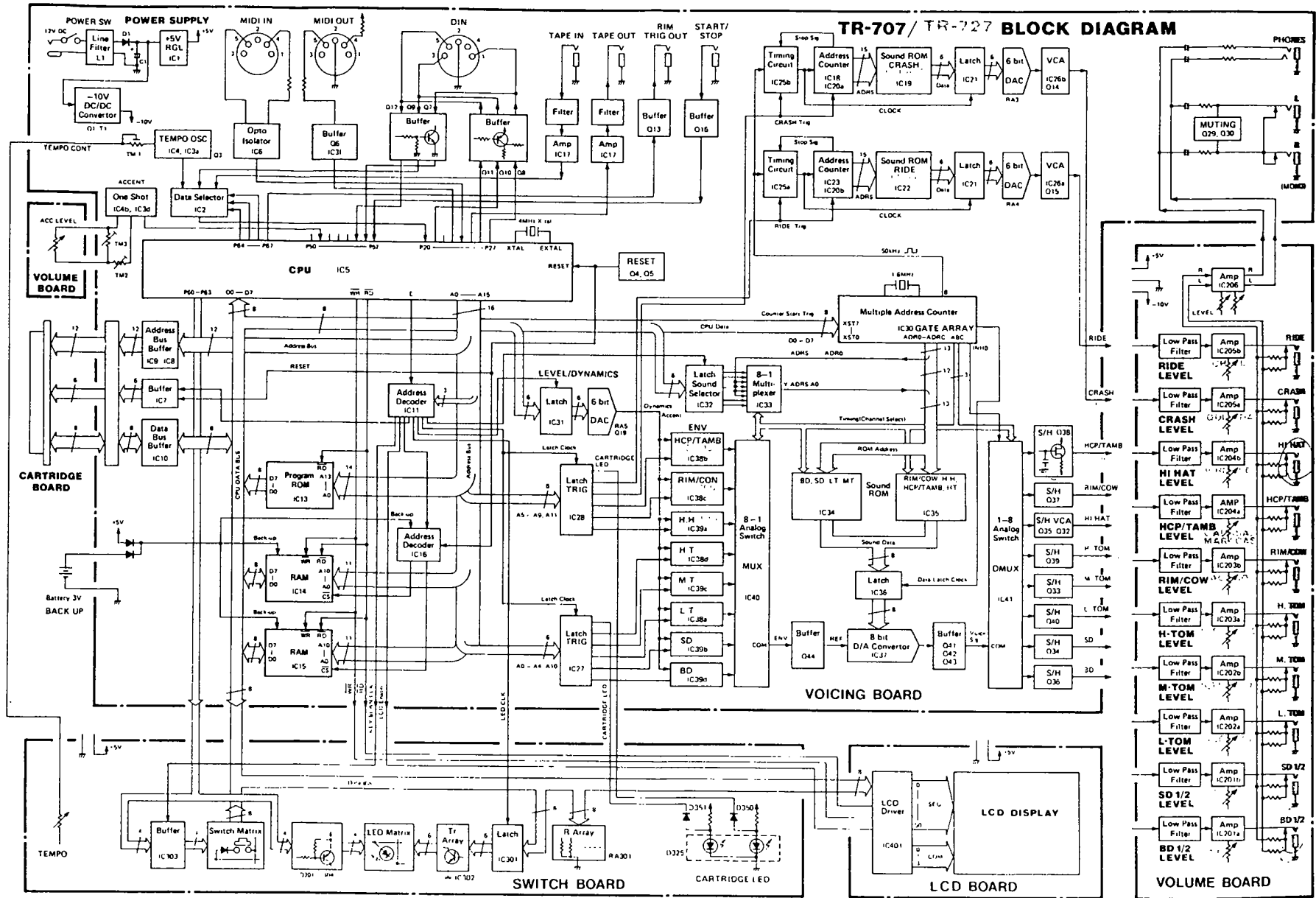

### CIRCUIT DESCRIPTIONS

TR-707 and TR-727 are designed based on the same circuit configuration, having more in common with each other. The differences between two models are sound data, component values in several audio stages and a couple of pin connections at IC30 of Voice board.

Both models derive all rhythm sounds from PCM-encoded samples of real sounds stored in ROM. Each waveform is stored either independently (e.g. CYMBAL) or together with another waveform as shown in Tables 1 and 2. Accordingly, sound reproducing circuits are classified into two: multiplex and single. The following description focuses on PCM sound reproduction system, taking TR-707 circuits as a representative.

### 回路解説

TR-707/727はROMにメモリされているPCM波形(サウンドデータ)を音源として利用しています。楽器の種類が異なる為一部に回路や定数の違いがあるもの、全体の回路構成は両機種に共通です。以下TR-707を例にとって説明します。

表1及び2から判る様、IC34、IC35 ICは複数音源のデータが、IC19、IC22 ICは単一音源がメモリされています。従って、これら音源データの読み出しから再生までの過程もシングル方式とマルチの種類があります。

### MULTIPLEX SOUND PROCESSING

#### MULTIPLE ADDRESS COUNTERS

IC30 RD63H114 on Voicing Board is a custom-LSI (called Gate Array) designed for use in PCM-sound multi-rhythm systems. The LSI assumes the key role in the TR 707 sound system. It incorporates a master clock generator, timing generator and 8 13-bit address counters. The timing generator, not only supplies clocks to these counters for generating address bits, but also feeds peripheral circuits with various timing clocks to sync the entire system operation. Of these timing clocks, A, B and C together make a channel-select code for signaling the ROMs (ICs 34, 35), MUX IC40 and DMUX IC41 which voice is being addressed by an address counter in IC30.

### マルチ音源

#### マルチアドレスカウンタ

多音源データをメモリしているROM(IC34,35)からのデータ読み出し、D/A変換、S/Hおよびその他の関連回路は、IC30 RD63H114をマスターとして動作します。RD63H114はマルチ音源機器用に開発されたカスタムLSIであって、内蔵のクロックおよびタイミング発生回路によりこれら外付回路を同期させるクロック信号を出力します。同期クロックのうちA、B、Cはボイス・チャンネルのセレクトコードを形成しますので特に重要です。IC30はROM(IC34,35)内の各音源データのアドレスを次々と出力して行きますが、A、B、Cは今どの音源アドレス(アドレス・カウンタのチャンネル番号)が出力されているかを、ROM以外のMUX IC40、DMUX IC41にも知らせます。(例SDの場合A=1、B=0、C=0。次頁のタイミングチャート参照)

MULTIPLEX SOUND SYSTEM BLOCK DIAGRAM

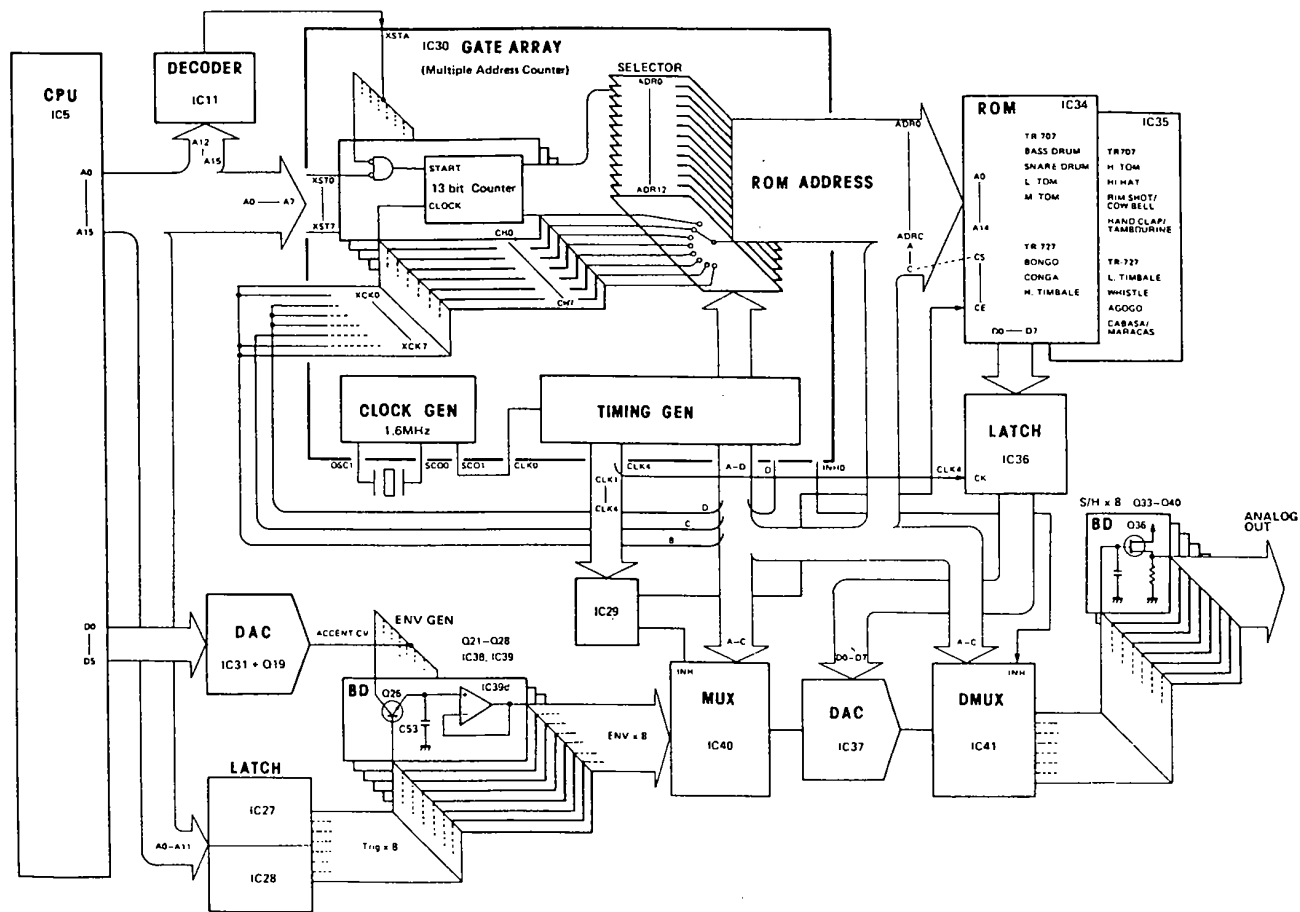

Now suppose that TR-707 is to run with BASS DRUM 1(BD-1) being selected, the CPU IC5 puts XST0 (CH0 start) and XSTA (XST0-XST7 enable) low, resetting counter 0, presetting it to the starting address 0000H and allowing it to count the clock pulse XCK0 from pin B in discrete steps. The counter continues counting until it increments up to 1FFFH and tops there until the next trigger pulse is received. While counting, the contents (a group of 13 clock pulses) of the counter is transferred to address selector where it is read every 40μs and is presented along ports ADRO through ADRC--13 lower address bits.

**PCM MEMORY READING**

IC34 and IC35, 32,768 word by 8 bit ROM, require 15 address bits to access their memory locations. Clocks A and B from IC30 serve as MSBs while C indicates which one of two ROMs is to be selected--Chip Select.

On the contrary, LSB ADRO is defeated when particular voice is selected: BD-1 and BD-2 share the same memory area with even addresses allocated to BD-1 and odd ones to BD-2 as shown in Table 1. With BD-1, data selector IC33 blocks ADRO and passes "0" data from IC32 onto AD of ROM IC35. With BD-2, IC33 selects "1". With Low Tom, Mid Tom, Hi Tom or Hi Hat, ADRO is allowed to reach AD.

Each 8-bit memory location (PCM waveform data) in ROM is loaded into latch IC36 on the rising edge of CLK4. This 8 bit data is, if converted to analog equivalent by D/A converter IC37 as it is, not restored to its original amplitude. A certain technic is involved during PCM to improve S/N ratio, to have higher resolution, etc. A signal coming from Envelope Generator into (+) REF pin gives right tone contour to a continual PCM waveforms being decoded and converted to an analog sound.

今 BASS DRUM1 (BD-1)が選択された状態で、リズムが走ったとすると、IC30にXST0(チャンネル0スタート)とXSTA(XST0-7イネーブル)が加わり、カウンタCH0は0000Hにリセットされた後XCK0に加えられて来るクロックBをカウントして行きます。この13ビット・アドレスカウンタのカウント値は40μs毎にアドレス・セレクタによりADR0-ADRC端子に出力されて行きます。(次にもう一度XST0が加わらない場合、カウンタは最大値1FFFHに達するとストップしたままとなります。)

**サウンド・データの読み出し**

256KビットROM IC34, IC35のメモリ・ロケーションにアクセスするには、15ビットのアドレスが必要です。残りのMSB2ビットにはIC30のA、Bクロックが当てられます。クロックCは、どちらのROMにアクセスするかを選ぶチップ・セレクトです。一方LSB ADROは、音源によってはROMアドレスとして使用されません。例えば、BD-1とBD-2は同じROMのメモリアreaを共有しており、BD-1には偶数のアドレスがBD-2には奇数アドレスが割当てられています。(表1参照)。この為、BD-1の場合、ROMのA0には常に"0"がIC32、IC33を通じて加えられます(BD-2の場合は"1")。

ROMから読み出されたサウンド・データは、IC37(ラダー・ネットワーク内蔵)でアナログ電圧に変換されリズム音波の一部(サンプリング波形)を再現しますが、振幅値は原音の値とは必ずしも一致しません。これはPCMの過程においてS/N比や分解能向上の処理が含まれている為です。再生音のエンベロープは、IC37の(+)REFに換り込むENV GENからの信号によって左右されます。

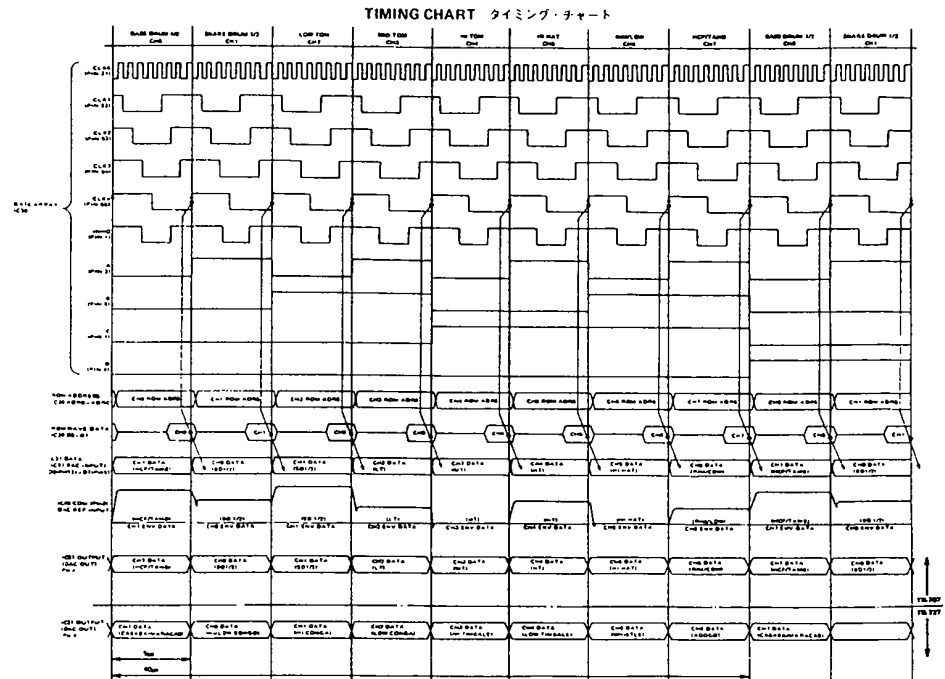

**ENVELOPE GENERATOR**

Data coming to latch IC31 is a combination of LEVEL and DYNAMICS (ACCENT). The value of LEVEL is always constant regardless of voice selected, while DYNAMICS varies with MIDI Velocity or ACCENT amount setting. Although LEVEL/DYNAMICS is connected to all 8 ENV GENERATORS it is allowed to enter only the transistor whose base-emitter junction, for example Q26, is being forward biased by a TRIG from latch IC27 or IC28 at XSTA rate. Q26 output is then connected by IC40 to (+) REF pin of IC37 every 40μs with its level decaying according to C53xR59 time constant as the successive BD-1 data are converted to analog voltages, giving a bass drum contour to the voice. The DAC output is boosted at Q41 and Q42 conjunction and is channeled into the S/H which is designated by A B C Code placed at IC41 select pins. As can be seen from the timing chart, the timing of envelope and D/A converting lag one bit behind the memory addressing. That is, BD-1 sound read from ROM with channel No. ABC=000 becomes an audible sound when channel No. is represented by ABC=100. This is because the data accessed on a positive going CLK4 with ABC=000 is latched into IC36 on the next CLK4 with ABC=100. Consequently, TRIG data to ICs 27 and 28, and LEVEL/DYNAMICS data to IC31 are made to delay one CLK4 cycle to keep pace with D/A conversion at IC37.

**エンベロープ・アクセント**

XSTA (XST0-7イネーブル)はIC30のアドレスカウンタに加えられると同時に、ラッチIC27、28のCLKにも加えられ、BD-1が選択されている時には、ENV GENのQ26がTRIGパルスによって導通し、LEVELとDYNAMICS (ACCENT)の混合された電圧がC53に充電されます。なお、LEVELの値はどの音源の場合でも常に一定です。また、LEVEL/DYNAMICS CVは8本全てのトランジスタに印加されますが、TRIGパルスが現在加わっているトランジスタにのみ流入します。Q26の出力はIC39dを通り、IC40により時分割でD/AコンバータのREF端子へ送られて行きますが、脈巾はC53xR59の時間定数に応じて減衰して行きます。時定数はBDのサウンド・データ全部がROMから読み出される時間より長くなる様に設定されています。

注 IC30のアドレス・カウンタのチャンネル番号とIC40/41のチャンネル番号が異なっています。これはROMのサウンドデータが、アクセスされた時よりCLK4の1サイクル分遅れてIC36にラッチされD/A変換される為です。したがってTRIGおよびLEVEL/DYNAMICSデータもその分遅れて出力されます。

TR-727 Sound Data ROM					
IC NO.	ROM	CE	CS	VOICE	MEMORY
IC34	HM61256PC71 (15179694)	H	L	HI BONGO	2N ADRES 4k byte
				LOW BONGO	2N + 1 ADRES 4k byte
				MUTE HI CONGA	2N ADRES 4k byte
				OPEN HI CONGA	2N + 1 ADRES 4k byte
				LOW CONGA	8k byte
HI CONGA	8k byte				
IC35	HM61256PC80 (15179695)	H	H	LOW TIMBALE	8k byte
				WHISTLE	8k byte
				HI ACCO	2N ADRES 4k byte
				HI ACCO	2N + 1 ADRES 4k byte
				CABASA	2N ADRES 4k byte
				MARACAS	2N + 1 ADRES 4k byte

TR-707 Sound Data ROM					
IC NO.	ROM	CE	CS	VOICE	MEMORY
IC34	HM61256PC71 (15179691)	H	L	BASS DRUM 1	2N ADRES 4k byte
				BASS DRUM 2	2N + 1 ADRES 4k byte
				SNARE DRUM 1	2N ADRES 4k byte
				SNARE DRUM 2	2N + 1 ADRES 4k byte
				LOW TOM	8k byte
				MID TOM	8k byte
IC35	HM61256PC72 (15179692)	H	H	HI TOM	8k byte
				HI HAT	8k byte
				RIM SHOT	2N ADRES 4k byte
				CON BELL	2N + 1 ADRES 4k byte
				HAND CLAP	2N ADRES 4k byte
				TAMBUKINE	2N + 1 ADRES 4k byte

Table 1 表1

**HI HAT**

Output from Q35 has no distinction between closed hi hat and open hi hat and is given a particular waveshape (decay) at VCA Q22 and IC42 as OPEN/CLOSED select signal is applied on the base of Q21.

**SINGLE SOUND PROCESSING**

Each of CYMBAL voices (RIDE and CRASH) has dedicated sound ROM, address counter, D/A converter and envelope generator. The difference from Multiplex processing in circuit configuration is that envelope control is accomplished after the wave data becomes analog form. LEVEL/DYNAMICS (ACCENT CV) routed to Q18 emitter (CRASH) is charged into envelope capacitor C50 on a TRIG, giving a contour to CRASH sound passing through Q14.

TR-707 Sound ROM

IC NO.	ROM	CE	CS	VOICE	MEMORY
IC19	HN61256PC73 (15179663)	H	L	CRASH CYMBAL	32k byte
IC22	HN61256PC74 (15179664)	H	L	RIDE CYMBAL	32k byte

Hi Hat に対しては、もう一度エンベロープ回路(VCA-IC42a, Q32)が追加されており、クローズかオープンかによりディケイタイムを切替えています。

**シングル音源**

RIDE CYMBAL および CRASH CYMBAL は、それぞれ専用のアドレス・カウンタ、ROM および D/A コンバータを持っていますが動作原理はマルチ音源の場合と変わりません。ただし、エンベロープが D/A 変換後 VCA に加えられる点の違いがあります。

TR-727 Sound ROM

IC NO.	ROM	CE	CS	VOICE	MEMORY
IC19	HN61256PC81 (15179696)	H	L	QUIJADA	32k byte
IC22	HN61256PC82 (15179697)	H	L	STAR CHIME	32k byte

Table 2 表2

**TESTING AND ADJUSTING**

The built-in test program executes the following test and adjusting routines while in Test Mode.

**RUNNING TEST PROGRAM**

While holding down CLEAR and INSTRUMENT, switch the power ON. The unit is now in the test mode and the test program initiates test routines with TEST 1.

**TEST 1. LED SEQUENTIAL LIGHTING**

Upon entering test mode the program lights up LEDs, starting with MAIN KEY 1 through SCALE INDICATOR, PATTERN GROUP and CARTRIDGE (red and green alternately) and repeats.

Leave the LEDs lighting and go to TEST 2.

**TEST 2. ALL LEDs AND LCD DOTS LIGHTING**

Press ENTER and verify lighting of all LEDs and LCD dots.

Leave them lit and go to TEST 3.

**TEST 3. SWITCHES AND ACCENT AMOUNT READING**

Press ENTER. All LCD display will be cleared OFF. Referring to the illustration below, push numbered buttons 1-32 one by one and check for the lighting of corresponding dot on either Bass Drum (BonGo) or Snare Drum (Hi Conga) row on the display window.

Slide up or down ACCENT and verify that TEMPO MEASURE window reads 1 and 16 at the extremities of travel.

**テストおよび調整**

TR-707, TR-727 には回路機能チェックおよび調整用のプログラムが内蔵されています。このプログラムを走らせるにはテストモードに入る必要があります。

**テストモード**

CLEAR と INSTRUMENT ボタンを同時に押しながら電源をオンするとテストモードとなり、テスト 1 が自動的に実行されます。

**テスト 1 LED 順次点灯**

テストモードに入ると、メインキーの 1 から順次 LED が点灯して行きます。CARTRIDGE の LED は赤と緑が交互に点灯します。

LED の点灯はくり返されますが、そのままの状態ですべて 2 へ進んで下さい。

**テスト 2 LED および LCD 全点灯**

ENTER を押します。全ての LED および LCD 上の全ドットが点灯する筈です。

そのままの状態ですべて 3 へ進んで下さい。

**テスト 3 スイッチおよびアクセントレベル読込み**

ENTER を押すと LCD のドットが消えます。パネル上のスイッチを押すと、右図に示す様に、対応した番号のドットが LCD の上に表示されます。



If not verified, go to ACCENT AMOUNT ADJUSTMENT below without exiting the test mode.

When all tests are satisfactory, turned the power off and on again to return to the normal operation mode (if necessary).

### ACCENT AMOUNT ADJUSTMENT

This test must be carried out in the test mode and follow the tests above.

1. Set ACCENT at MIN and adjust TM2 of VOICING board for a transition point of "1" to/from "2" of TEMPO MEASURE display reading.
2. Set ACCENT at MAX and adjust TM3 for a transition point of "15" to/from "16" of TEMPO MEASURE display reading.

The unit will remain in the test mode until the power is turned OFF.

### TEMPO CLOCK RATE ADJUSTMENT

This adjustment must be done in the normal operation mode.

1. Set TEMPO at FAST and adjust TM1 of VOICING board for 250 reading on TEMPO MEASURE window.

次に、アクセント（AC）つまみを上下させるとLCDのTEMPO/MEASURE部に数字が表示されます。MINの位置で"1"、MAXで"16"とならない場合は、次のアクセントレベル調整へ進んで下さい。

調整が不要で、通常モードに戻るには一旦電源をオフして下さい。

### アクセントレベル調整

本調整はテストモードで行ないます。上記のテストの後で行なって下さい。

1. アクセント（AC）をMINにセットし、TM2（ボイシング基板）でTEMPO/MEASUREの表示が"1"か"2"になる臨界点に調整します。
2. ACをMAXにセットし、TM3で表示が"15"か"16"になる臨界点に調整します。

### テンポ調整

本調整は通常モードで行ないます。テストモードになっている場合は、一度電源をオフして下さい。

TEMPOをFASTにセットし、TM1（ボイシング基板）でTEMPO/MEASUREの表示が250になる様調整します。

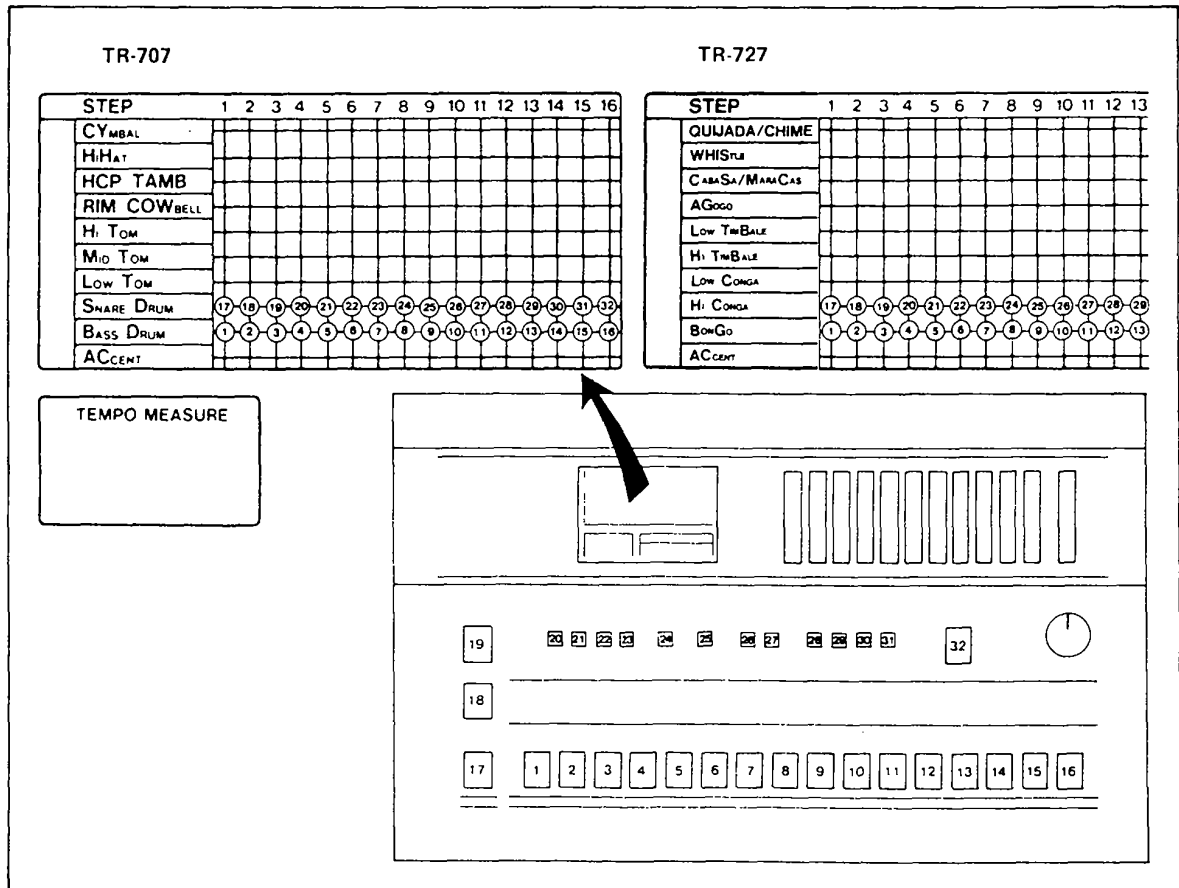

TR-707/727 GENERAL CIRCUIT DIAGRAM

VOICING BOARD (Detail on page 10)

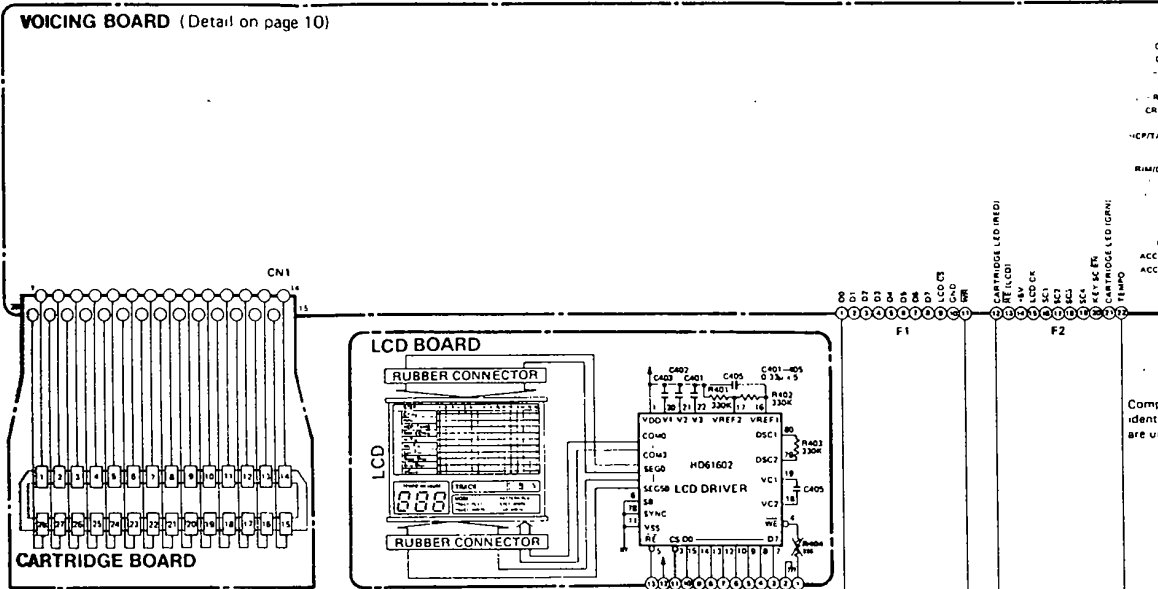

Component values identical to above are unspecified.

SWITCH BOARD

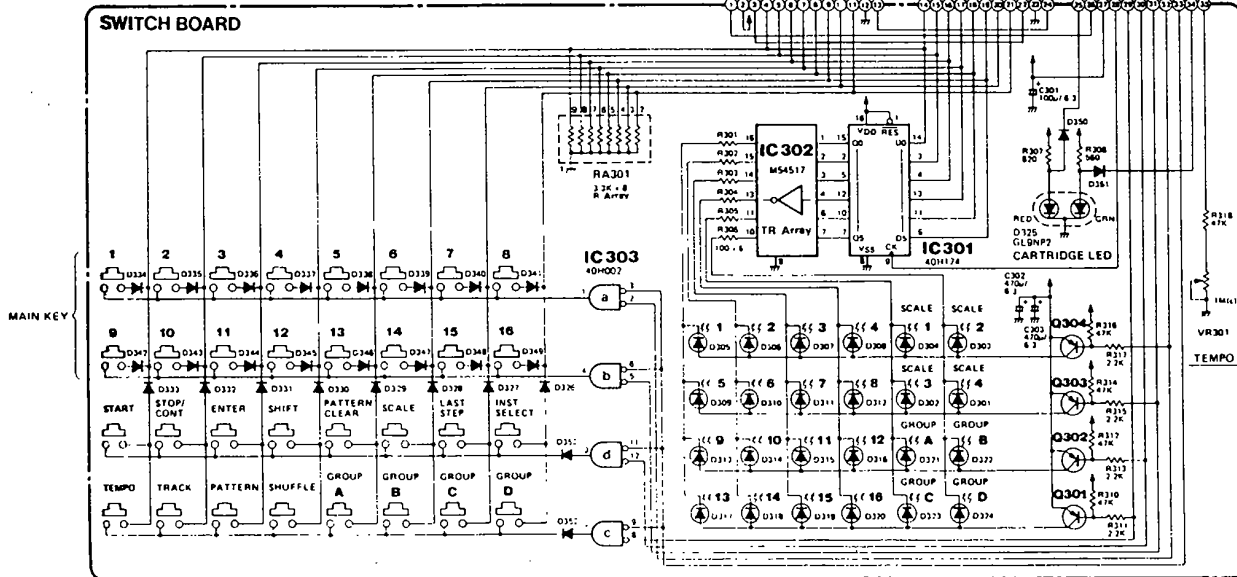

MAIN KEY LED

VOLUME BOARD

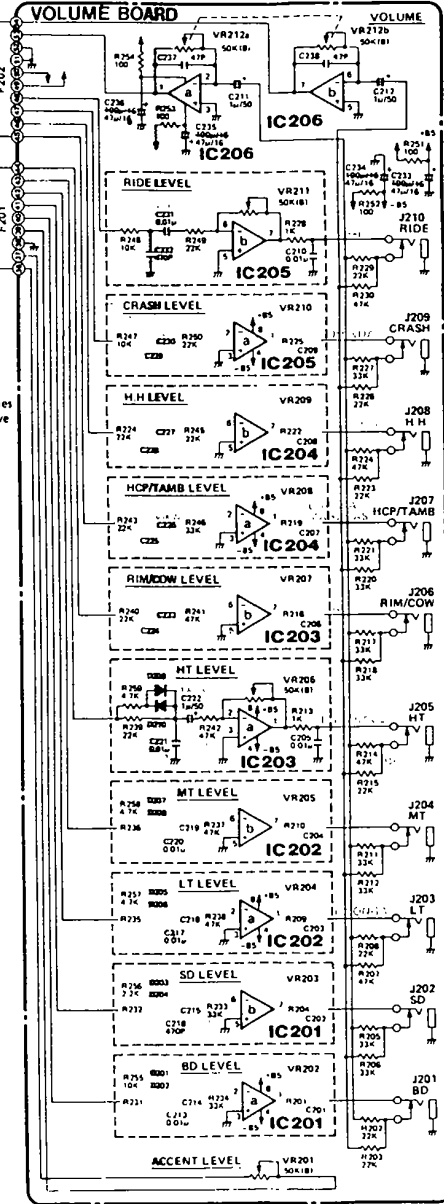

### VOLUME BOARD

**TR-707** 7313605000 (pcb 2291098002)

**TR-727** 7313805000 (pcb 2292019000)

View from foil side

BELOW PCB LAYOUT For TR-707

TR-727 is identical to TR-707's except for those represented in red in the circuit diagram left.

下の基板図はTR-707用です。

TR-727の場合は回路図の赤線表示に従って相違点を確認して下さい。

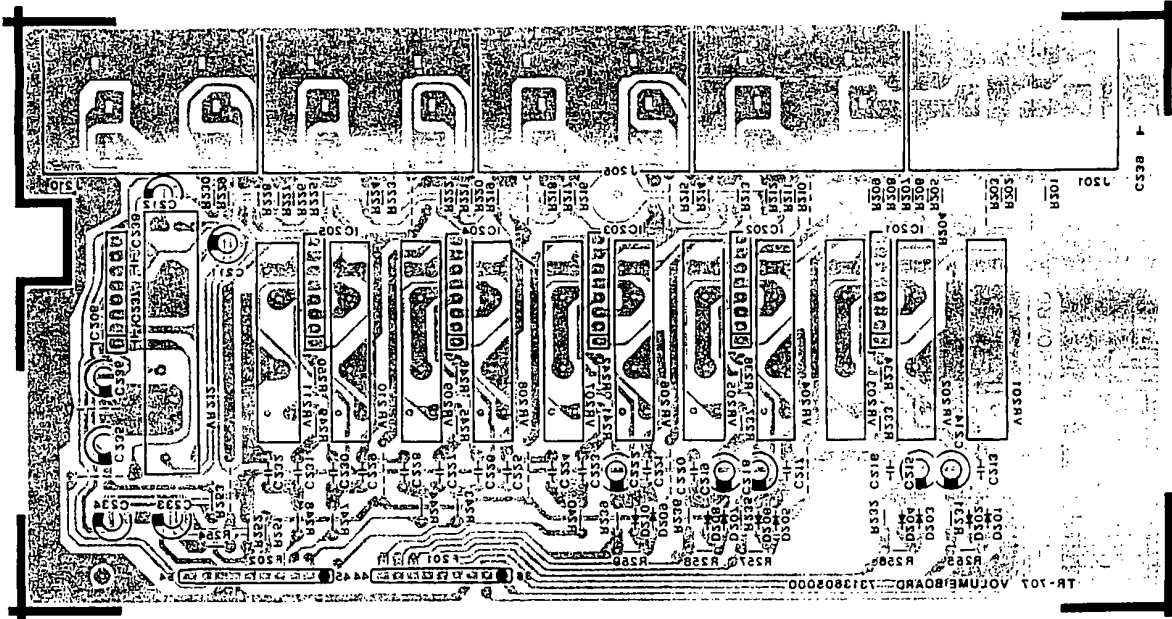

### SWITCH BOARD

7313606000 (pcb 2291097903)

View from foil side

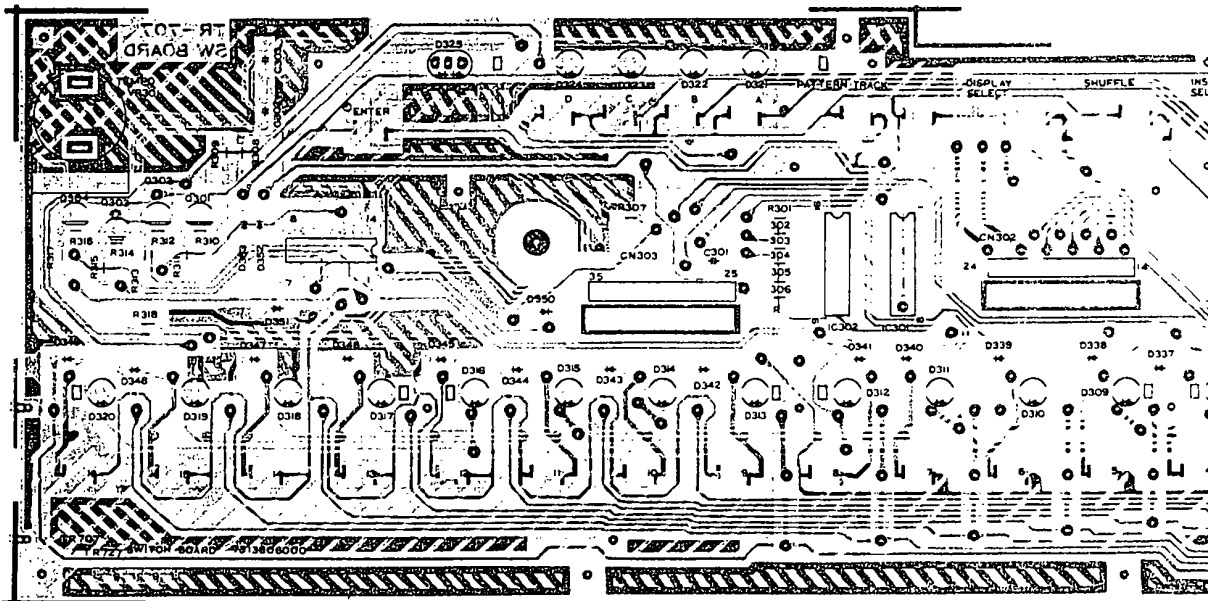

**LCD BOARD**

7313607000

(pcb 2291098203)

View from foil side

UT For TR-707

R-707's except for those represented in red  
diagram left

緑表示に従って相違点を確認して下さい。

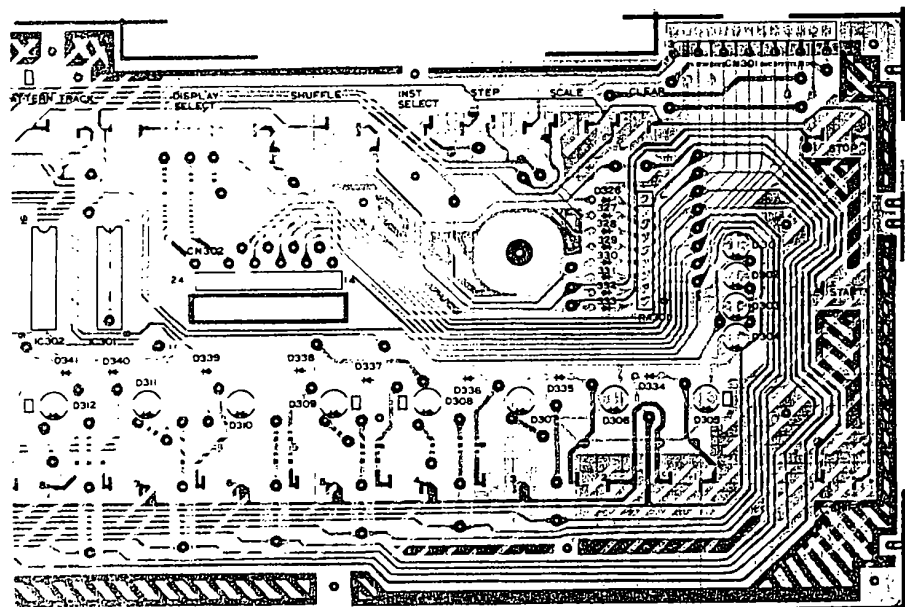
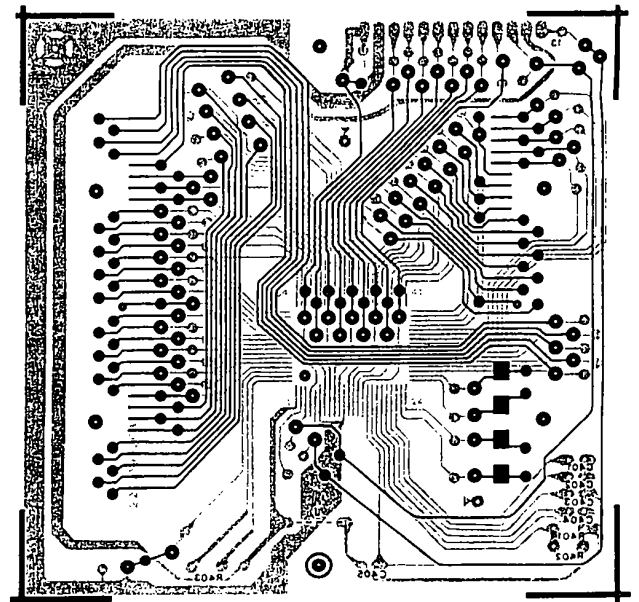
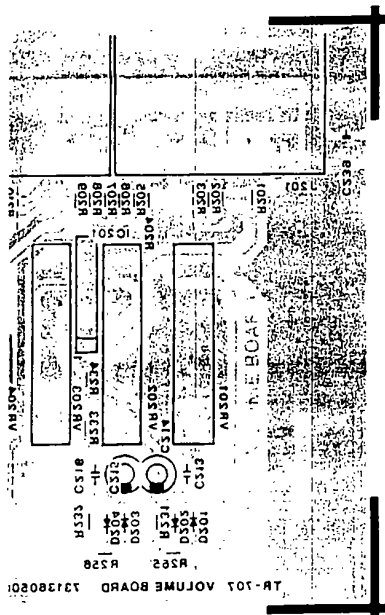

1 2 3 4 5 6 7 8 9 10 11 12 13 14 15 16

A  
B  
C  
D  
E  
F  
G  
H  
I  
J  
K  
L  
M  
N  
O  
P  
Q  
R  
S

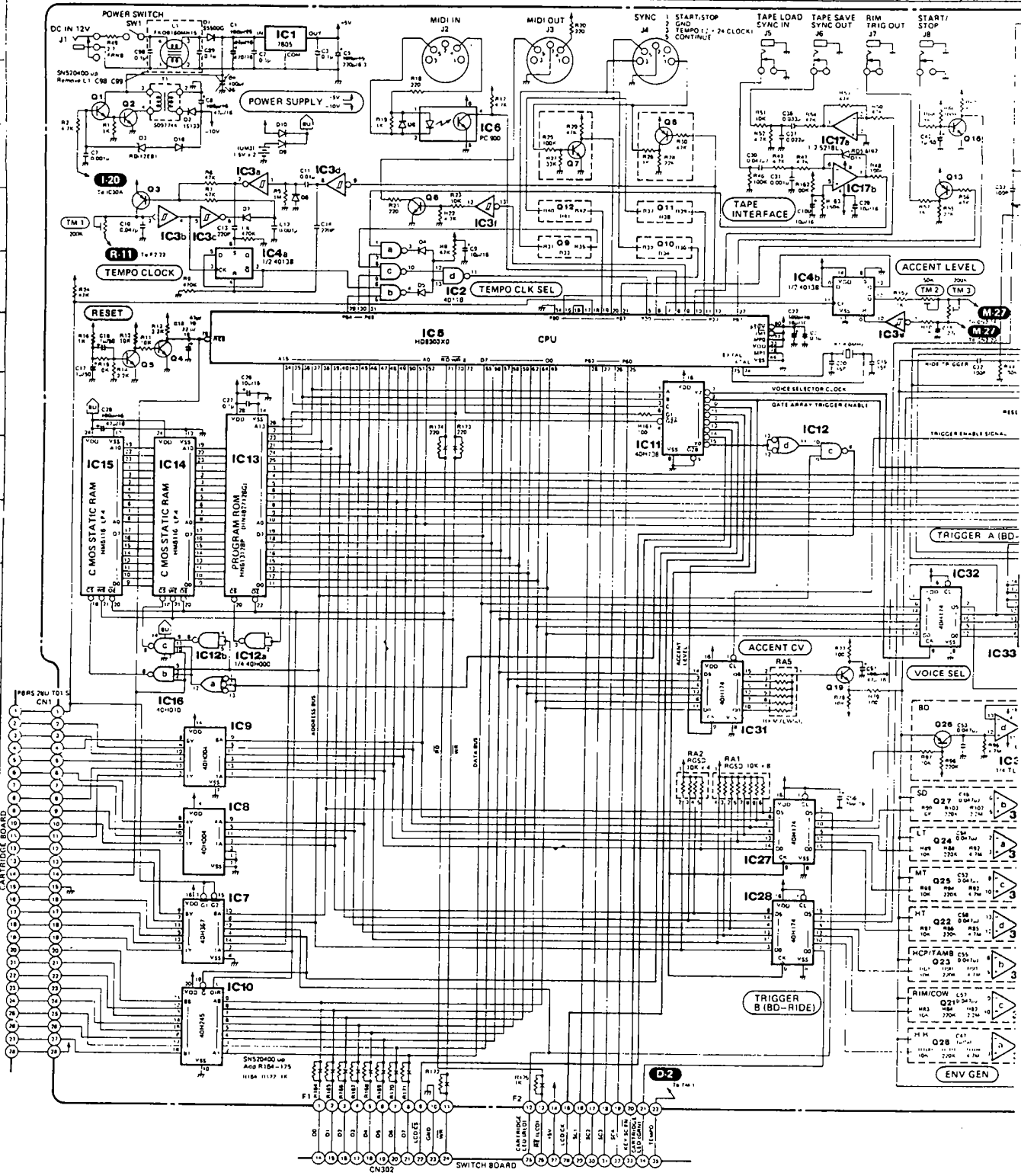

12 13 14 15 16 17 18 19 20 21 22 23 24 26 27 28

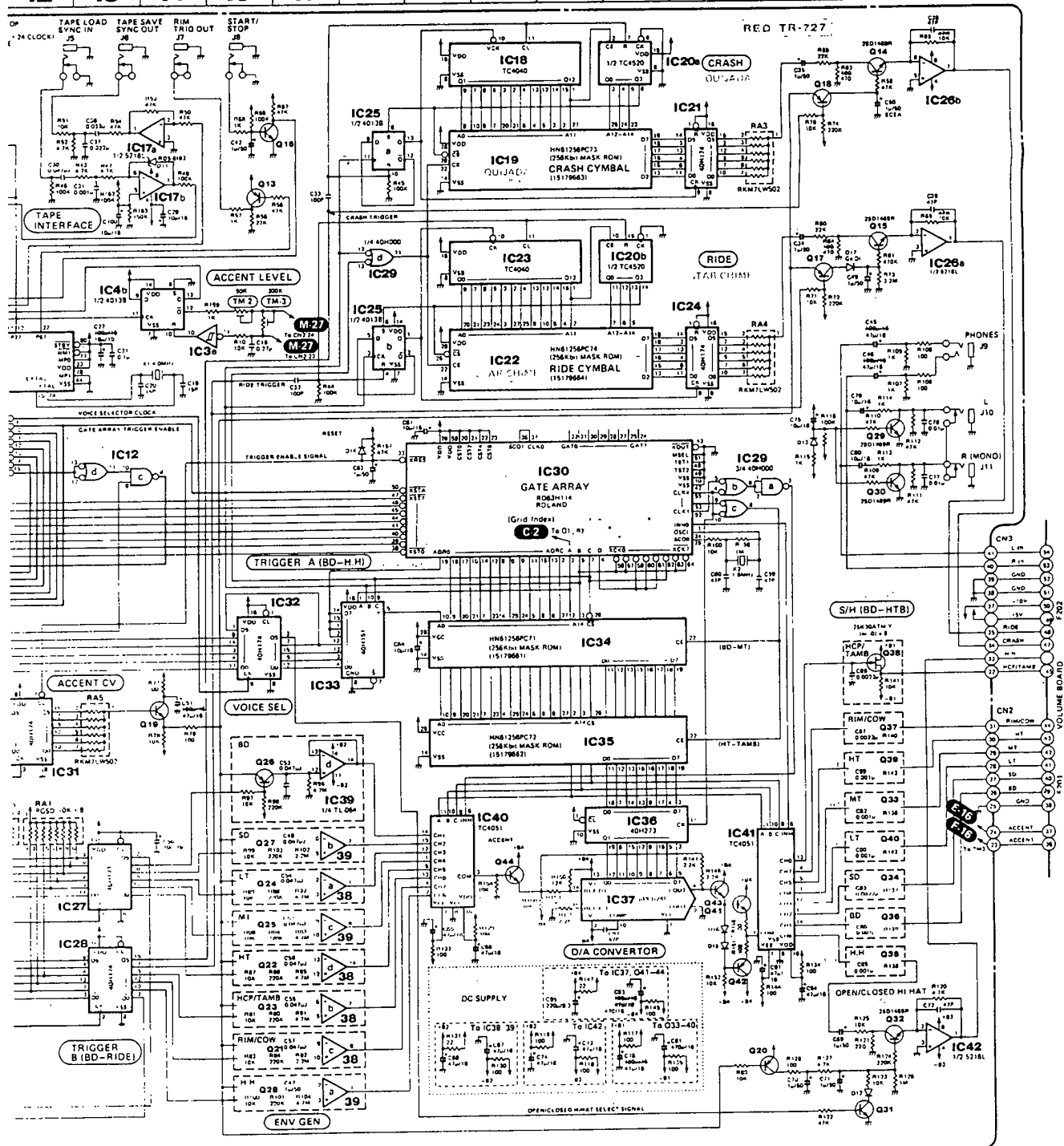

# VOICING BOARD

**TR-707** 7313604000 (pcb 2291098102)  
**TR-727** 7313804000 (pcb 2292018900)

BELOW PCB LAYOUT For TR-707  
TR-727's: identical to TR-707's except for those represented in red  
in the circuit diagram left.

下の基板図はTR-707用です。  
TR-727の場合は回路図の赤線表示に従って相違点を確認して下さい。

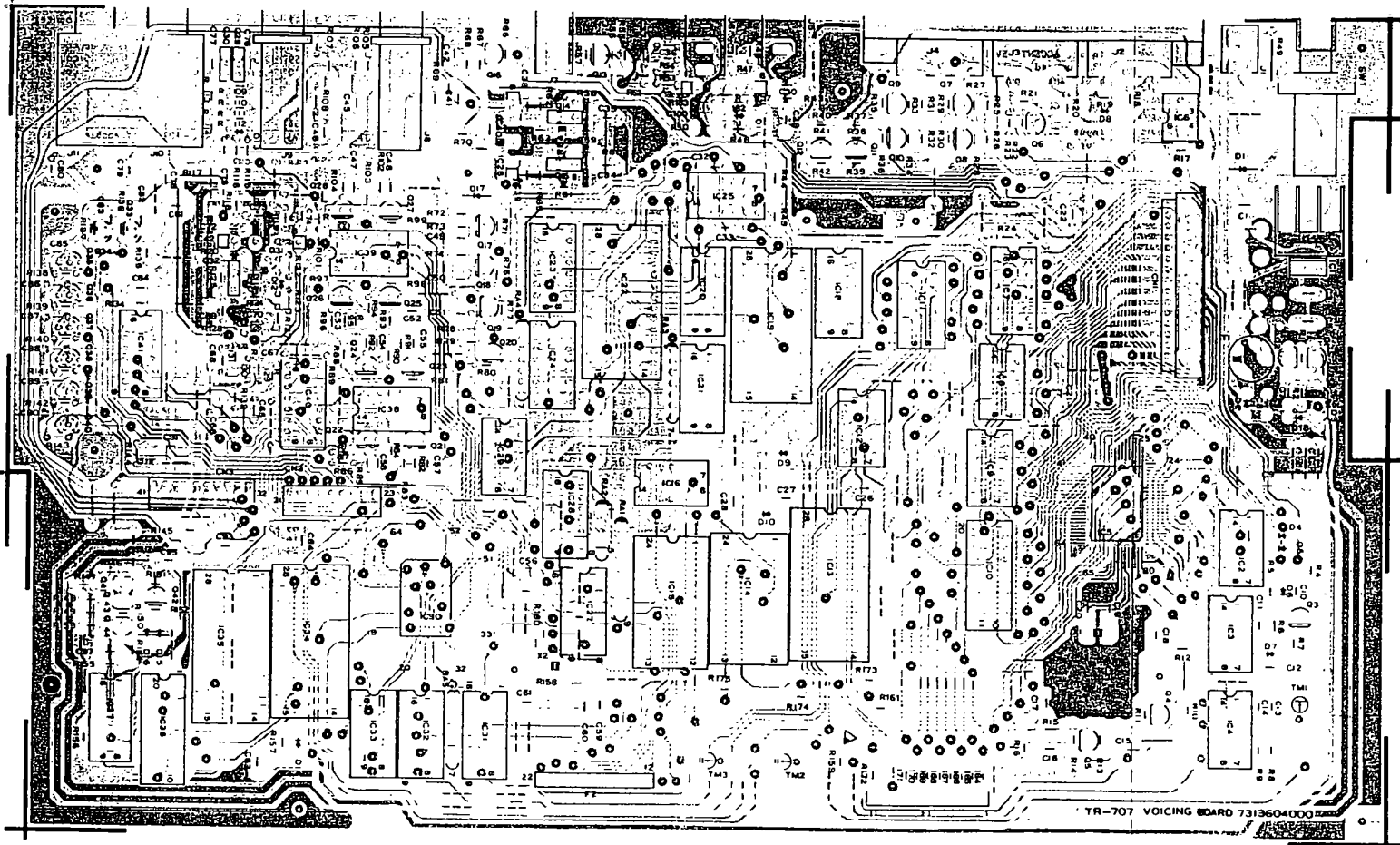

View from foil side

IC DATA

**CPU HD6303X**

Pin Configuration (Top View)

Port Assignment

PIN NO.	PORT NAME	DESCRIPTION
1	NR1	Unused, pulled up +5V
2-4	NC	Unused, open
5	P70	input, TEMPO CLOCK
6	P21	output, TEMPO CLOCK (DIN)
7	P22	output, ACCENT LEVEL input trigger for internal ADC
8	P23	input, MIDI IN
9	P24	output, MIDI OUT
10	P25	output, TAPE SYNC
11	P26	output, COMT START (DIN)
12	P27	output, START/STOP (DIN)
13	NC	unused, open
14	P50	IRQ1 unused, pulled down
15	P51	IRQ2
16	P52	MR unused, pulled up +5V
17	P53	HALT unused, pulled up +5V
18	P54	RAM cartridge control
19	P55	input, COMT START (DIN IN)
20	P56	input, START/STOP (DIN IN)
21	P57	input, START/STOP from remote control
22-24	NC	unused, open
25-28	P60-P63	output, scanning signal to LED and KEY
29	P64	output, Internal TEMPO CLOCK
30	P65	output, DIN SYNC TEMPO CLOCK
31	P67	output, TAPE SYNC TEMPO CLOCK
32	P66	output, Trigger (MIM SHOT:TR-707)(HI AGOGO:TR-727)
33	Vcc	input, +5V power supply
34-40	A15-A9	output, address A15---A19
41-42	NC	unused, open
43	A8	output, address A8
44	Vss	GND
45-52	A7-A0	output, address A7---A0
53-54	NC	unused, open
55-59	D7-D3	data bus D7---D3
60-61	NC	unused, open
62	D2	data bus D2
63	NC	unused, open
64-65	D1-D0	data bus D1---D0
66	BA	output, unused
67	LIR	output, unused
68	NC	unused, open
69	R/W	output, unused
70	WR	output, unused
71	RD	output, unused
72	E	output, system clock 1MHz
73	Vss	GND
74	XTAL	terminal, Xtal
75	EXTAL	terminal, Xtal or external system clock in
76	NC	unused, open
77	WPO	input, MCU mode setting pulled up +5V
78	MPI	input, MCU mode setting pulled down GND
79	RES	input, MCU reset (active low)
80	STBY	unused, pulled up +5V (active low)

**μPC624C**

Pin Configuration (Top View)

Block Diagram

**GATE ARRAY RD63H114**

Pin Configuration (Top View)

PIN	NAME	PIN	NAME	PIN	NAME
1	INH0	23	CST6	45	TST5
2	ADRC	24	GATE7	46	XST6
3	A	25	GATE6	47	TST7
4	D	26	VDD	48	TST1
5	B	27	GATE5	49	TST2
6	ADR7	28	GATE4	50	XSTA
7	C	29	GATE3	51	MSEL
8	ADR6	30	GATE2	52	CLK1
9	ADR8	31	GATE1	53	CLK2
10	VSS	32	GATE0	54	CLK3
11	ADR9	33	XRES	55	CLK4
12	ADR5	34	OSC1	56	XCK0
13	ADR8	35	SC00	57	XCK1
14	ADR4	36	SC01	58	VDD
15	ADR3	37	CLK0	59	XCK2
16	ADRA	38	XST0	60	XCK3
17	ADR2	39	XST1	61	XCK4
18	ADR1	40	XST2	62	XCK5
19	ADST0	41	XST3	63	XCK6
20	CST0	42	VSS	64	XCK7
21	CST2	43	XOUT		
22	CST4	44	XST4		

Multiple Address Counters

DESIGNATION	PIN	DESCRIPTION	I/O	
CST	0	20		
	2	21	pulled up (+5V) continue start	
	4	22		
	6	23		
	8	23		
XST	A	50	XST0-XST7 enable, active low	
	0	38		
	1	39		
	2	40		counter start, active low
	3	41		
	4	44		
	5	45		
	6	46		
	7	47		
XCK	0	56	counter 0	
	1	57		
	2	59		
	3	60		counter clock input
	4	61		
	5	62		
	6	63		
	7	64		
XOUT	43		address(ADRO-ADRC) out enable, active low; high-HI z	
ADR	0	19	ROM ADDRESS	
	1	18		
	2	17		
	3	15		
	4	14		
	5	12		
	6	8		
	7	6		
	8	9		
	9	11		
A	3		MUX, DMUX channel select	
B	5			
C	7			
D	4			
INH0	1		DMUX inhibit	
OSC1	34			internal clock generator
SC00	35			
SC01	36			
CLK	0	37	system clock in 1.6MHz	
	1	52		
	2	53		
	3	54		MUX inhibit
	4	55		
XRES	33		reset pulse, active low	
MSEL	51			counter 12/13 bit select
TST1	48			
TST2	49			
Vss	10		GND	
Vdd	42			
VDD	26		power supply +5V	
CAT	0	32		
	1	31		
	2	30		
	3	30		
	4	29		
	5	28		
	6	25		
	7	24		



# TR-707/TR-727 MIDI IMPLEMENTATION

## 1. TRANSMITTED DATA

Status	Second	Third	Description
1001 0000	0000 0000	0000 0000	NOTE ON (TR 727 only)
1001 0000	0000 0000	0000 0000	NOTE OFF (TR 727 only)
1011 0010	0000 0000	0000 0000	Temp. Octave Transpose
1011 0011	0000 0000	0000 0000	Temp. Release Transpose
1011 1000	0000 0000	0000 0000	Temp. Check
1011 1001	0000 0000	0000 0000	Temp. Stop
1011 0000	0100 0001	0000 0000	Sequence Data (TR 727)

Notes: #1 Transmitted channel B can be changed to 1 - 16 from the front panel when the power is applied. The correct channel B set prior to the last power OFF remains unchanged.  
 #2 When the message number is set.  
 #3 When the track # is set.

Track #	SSSSSS
1	0
2	2
3	2
4	3

Tempo Mode Synchronized with  
 Internal tempo clock  
 MIDI mode received timing clock  
 Disk mode positive edge of the Disk clock

Notes: #1 Note numbers are defined as follows:  
 Setting A: normal  
 Setting B: When the MIDI Ch (non LAST STEP) buttons are pressed while the "SHIFT" button is being pressed

TR-727	Key Name	Setting A	Setting B
	Mr. Bongo	68	35
	Low Bongo	61	36
	Open Mr. Conga	62	38
	Open Mr. Conga	63	38
	Low Conga	64	41
	Mr. Timbale	65	41
	Low Timbale	66	46
	Mr. Agogo	67	47
	Low Agogo	68	56
	Cajon	69	59
	Maracas	70	54
	Short Whistle	71	42
	Long Whistle	72	46
	Guijros	73	44
	Star Chain	74	51

## 2. RECOGNIZED RECEIVE DATA

Status	Second	Third	Description
1001 0000	0000 0000	0000 0000	NOTE ON (TR 727)
1001 0000	0000 0000	0000 0000	NOTE OFF (TR 727)
1011 0010	0000 0000	0000 0000	Temp. Octave Transpose
1011 0011	0000 0000	0000 0000	Temp. Release Transpose
1011 1000	0000 0000	0000 0000	Temp. Check
1011 1001	0000 0000	0000 0000	Temp. Stop
1011 0000	0100 0001	0000 0000	Sequence Data (TR 727)

Notes: #1 Received channel B can be changed to 1 - 16 from the front panel when the power is applied. The correct channel B set prior to the last power OFF remains unchanged.  
 #2 Recognized while in the Track Play mode.  
 Any of the key numbers (35 - 88) may be assigned to each instrument from panel operation, and will be kept assigned even after the power is turned OFF.  
 Received note numbers are assigned at the factory as follows:

TR-727	Instrument
68	Mr. Bongo
61	Low Bongo
62	Open Mr. Conga
63	Open Mr. Conga
64	Low Conga
65	Mr. Timbale
66	Low Timbale
67	Mr. Agogo
68	Low Agogo
69	Cajon
70	Maracas
71	Short Whistle
72	Long Whistle
73	Guijros
74	Star Chain

TR-707	Instrument
35	Base Drum 1
36	Base Drum 2
37	Tom Snare
38	Snare Drum 1
39	Hand Clap
40	Snare Drum 2
41, 42	Low Tom
43	Closed Hi-Hat
44, 45	Hi-Hat
46	Open Hi-Hat
48, 50	Crash Cymbal
49	Crash Cymbal
51	Ride Cymbal
54	Handbell
56	Cowbell

All the Note OFF messages are ignored.  
 #3 Recognized while the last STOPS in the Track Play mode.  
 #4 When the SYNC mode is at MIDI.  
 While in the Tap Inhibit mode, all MIDI messages are ignored.

## 3. HANDSHAKING COMMUNICATION

### 3.1 Message Type

Byte	Description
0111 0000	Exclusive status
0100 0001	Release ID #
0101 0000	Operation code
0111 0111	End of System Exclusive
1000 0000	512 data bytes (256 bytes of argument)
0000 0000	0000 0000
0100 0001	Check sum (for preceding 512 data bytes)
0111 0111	End of System Exclusive

Note: Summed value of the all bytes in data and the check sum must be 0111 0111.

Byte	Description
0111 0000	Exclusive status
0100 0001	Release ID #
0101 0000	Operation code
0111 0111	End of System Exclusive

Byte	Description
0111 0000	Exclusive status
0100 0001	Release ID #
0101 0100	Operation code
0111 0111	End of System Exclusive

Byte	Description
0111 0000	Exclusive status
0100 0001	Release ID #
0101 0000	Operation code
0111 0111	End of System Exclusive

Byte	Description
0111 0000	Exclusive status
0100 0001	Release ID #
0101 0000	Operation code
0111 0111	End of System Exclusive

Byte	Description
0111 0000	Exclusive status
0100 0001	Release ID #
0101 0000	Operation code
0111 0111	End of System Exclusive

### 3.2 Sequence of Communication

Request	Response
ROF	Request a file (received)
DAI	Data (transmitted)
CSI	Continue (transmitted)
PAS	Acknowledge (received)
DAI	Data (transmitted)
ROF	Request a file (received)
PAS	Acknowledge (received)

Request	Response
WSP	Want to send a file (received)
ROF	Request a file (received)
DAI	Data (received)
CSI	Continue (received)
PAS	Acknowledge (transmitted)
DAI	Data (received)
LOF	End of file (received)
PAS	Acknowledge (transmitted)

Request	Response
WSP	Want to send a file (received)
WIC	Warning (received)
ROF	Request a file (received)
WIC	Warning (received)
ROF	Request a file (received)
WIC	Warning (received)

Request	Response
ROF	Request a file (received)
WIC	Warning (received)
ROF	Request a file (received)
WIC	Warning (received)
ROF	Request a file (received)
WIC	Warning (received)

DAI Data (transmitted)  
 CSI Continue (transmitted)  
 PAS Acknowledge (received)  
 WSP Warning (received)  
 WIC Warning (received)