

BOSS

MIDI PAD

MPD-4

INSTRUCTIONS

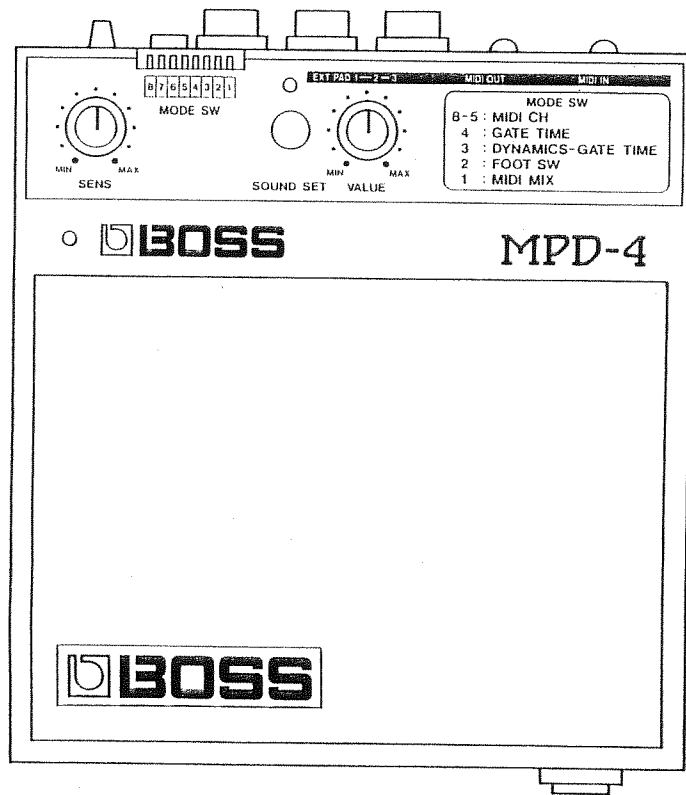

Please read the instructions carefully.

The MPD-4 is the MIDI Pad Controller that can control the MIDI device such as a MIDI rhythm machine, MIDI drum sound module, MIDI synthesizer, etc.

- Up to three external pads (such as BP-1) can be used together with the MPD-4's.
- Using the optional Footswitch (such as FS-5U) greatly widens the variety of performance.
- Using the Footswitch and external pads, up to 8 different sounds can be played by the MPD-4.
- If using a synthesizer as a sound module, the sounding time (=gate time) of the sound can be controlled with the MPD-4.

RADIO AND TELEVISION INTERFERENCE

Warning – This equipment has been verified to comply with the limits for a Class B computing device, pursuant to Subpart J, of Part 15, of FCC rules. Operation with non-certified or non-verified equipment is likely to result in interference to radio and TV reception.

The equipment described in this manual generates and uses radio-frequency energy. If it is not installed and used properly, that is, in strict accordance with our instructions, it may cause interference with radio and television reception.

This equipment has been tested and found to comply with the limits for a Class B computing device in accordance with the specifications in Subpart J, of Part 15, of FCC Rules. These rules are designed to provide reasonable protection against such a interference in a residential installation. However, there is no guarantee that the interference will not occur in a particular installation. If this equipment does cause interference to radio or television reception, which can be determined by turning the equipment on and off, the user is encouraged to try to correct the interference by the following measure:

- Disconnect other devices and their input/output cables one at a time. If the interference stops, it is caused by either the other device or its I/O cable.
- These devices usually require Roland designated shielded I/O cables. For Roland devices, you can obtain the proper shielded cable from your dealer. For non Roland devices, contact the manufacturer or dealer for assistance.
- If your equipment does cause interference to radio or television reception, you can try to correct the interference by using one or more of the following measures:
 - Turn the TV or radio antenna until the interferences stops.
 - Move the equipment to one side or the other of the TV or radio.
 - Move the equipment farther away from the TV or radio.
 - Plug the equipment into an outlet that is on a different circuit than the TV or radio. (That is, make certain the equipment and the radio or television set are on circuits controlled by different circuit breakers or fuses.)
 - Consider installing a rooftop television antenna with coaxial cable lead-in between the antenna and TV.

If necessary, you should consult your dealer or an experienced radio/television technician for additional suggestions. You may find helpful the following booklet prepared by the Federal Communications Commission:

"How to Identify and Resolve Radio-TV Interference Problems"
 This booklet is available from the U.S. Government Printing Office, Washington, D.C., 20402, Stock No. 004-000-00345-4.

Bescheinigung des Herstellers/Importeurs

Hiermit wird bescheinigt, daß der/die/das

BOSS MIDI PAD MPD-4

(Gerät, Typ, Bezeichnung)

in Übereinstimmung mit den Bestimmungen der

Amtsbl. Vfg 1046 / 1984

(Amtsblattverfügung)

funk-enstört ist.

Der Deutschen Bundespost wurde das Inverkehrbringen dieses Gerätes angezeigt und die Berechtigung zur Überprüfung der Serie auf Einhaltung der Bestimmungen eingeräumt.

Roland Corporation Osaka/Japan

Name des Herstellers-Importeurs

1 PANEL DESCRIPTION

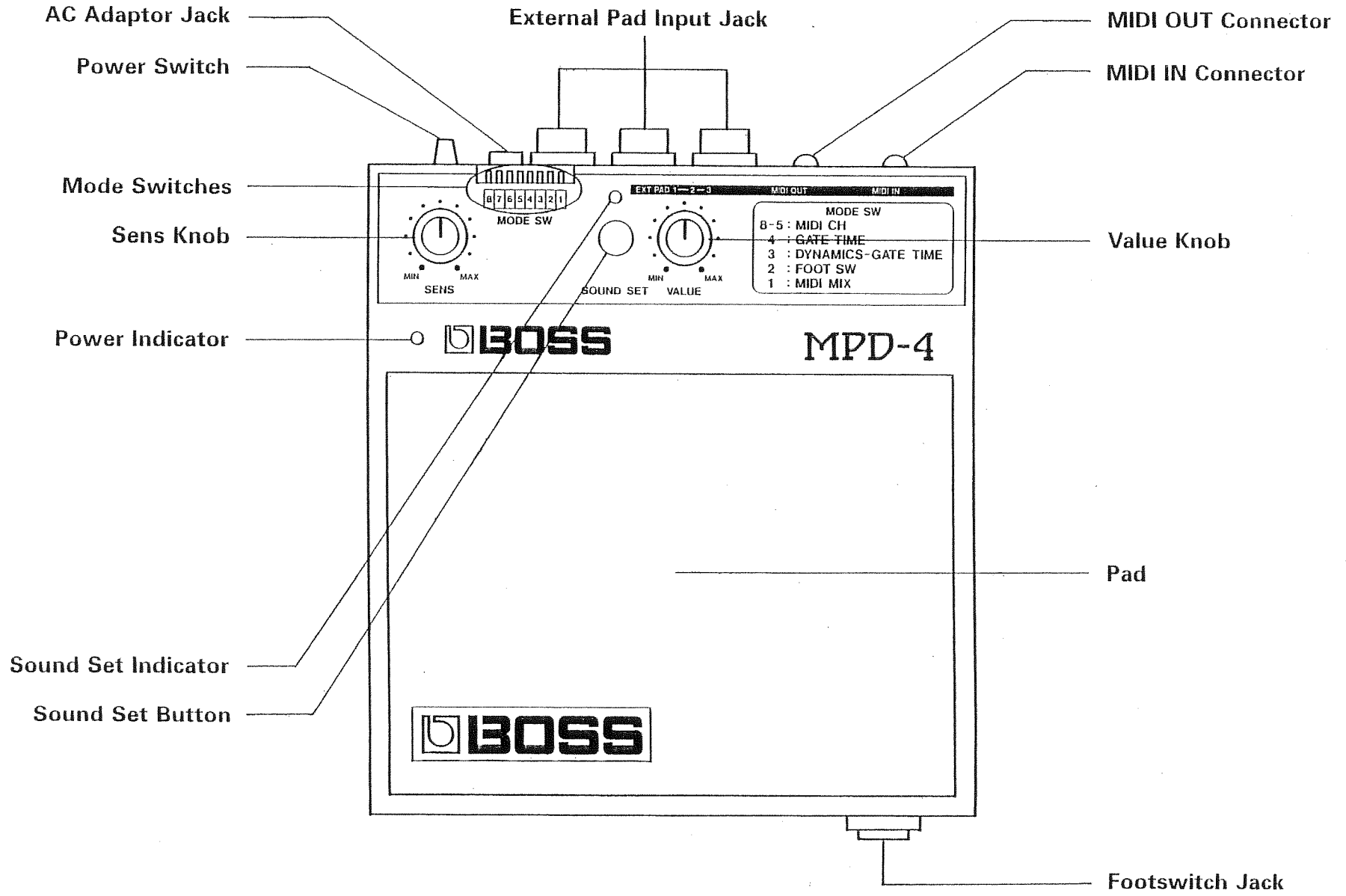

CONTENTS

1 Panel Description	3
2 Basic Connection	5
3 Operation	6
1. Setting MIDI Channels	6
2. Playing a Rhythm Machine	7
3. Playing the other Sound Module	11
4. How to use the Footswitch	16
5. External Pad	18
6. Installing the Tom Stand	20
7. Other Useful Functions	21
4 Battery Replacement	22
5 When your MPD-4 is in trouble	23
6 Specifications	24

Please read the separate booklet "MIDI" before reading these instructions.

IMPORTANT NOTES

- * Operating this unit near a neon or fluorescent lamp may cause noise interference. If so, change the angle or the position of the unit.
- * Avoid using this unit in excessive heat or humidity or where it may be affected by direct sunlight or dust.
- * Use a soft cloth and clean only with a mild detergent.
- * Do not use solvents such as paint thinner.
- * Please use the AC adaptor PSA-120, 220 or 240 depending on the voltage system in your country.
- * The sensitivities of the MPD-4 and external pad BP-1 (optional) are set sufficiently high, therefore, you do not need to hit them so hard. Hitting the pads too hard will cause various troubles or even breakdown.
- * If the unit is not to be used for a long period of time, remove the battery to avoid the trouble caused by battery leakage.

2 BASIC CONNECTION

Connect the MIDI OUT of the MPD-4 to the MIDI IN of the unit used as a sound source (e.g. rhythm machine, synthesizer, etc).

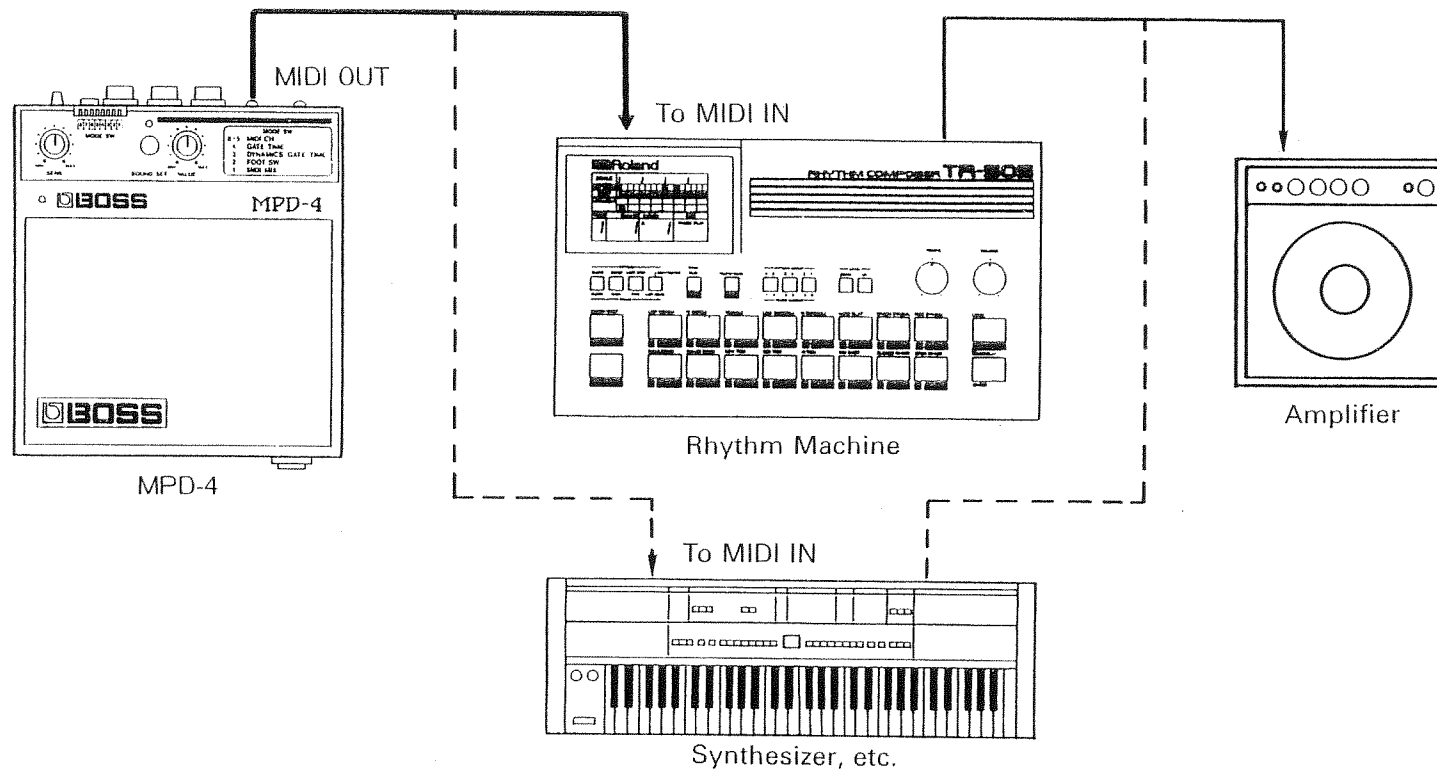

3 OPERATION

To play the sound source with the MPD-4, at least the following "1." and "2." (or 1. and 3.) are essential.

1. Setting MIDI Channels

Set the transmit channel of the MPD-4 to the same number as the receive channel of the sound source unit (e.g. a rhythm machine, synthesizer). The MIDI channel of the MPD-4 is determined by ON or OFF of the Mode Switches 5 to 8 as shown on the front panel.

MODE SW - MIDI CH		○ ON ● OFF															
SW \ CH	1	2	3	4	5	6	7	8	9	10	11	12	13	14	15	16	
5	●	○	●	○	●	○	●	○	●	○	●	○	●	○	●	○	
6	●	●	○	○	●	●	○	○	●	●	○	○	●	●	○	○	
7	●	●	●	●	○	○	○	○	●	●	●	○	○	○	○	○	
8	●	●	●	●	●	●	●	○	○	○	○	○	○	○	○	○	

Mode Switches 5 - 8

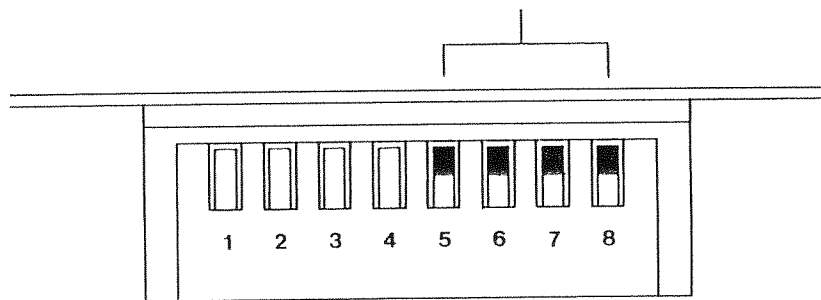

* When the sound source unit is set to OMNI ON (that receives messages on all channels), you do not need to change MIDI Channels.

The Roland TR-707 and the TR-505 are set to MIDI channel number 10 at the manufacturer. So if it remains intact, set the MPD-4 as shown below.

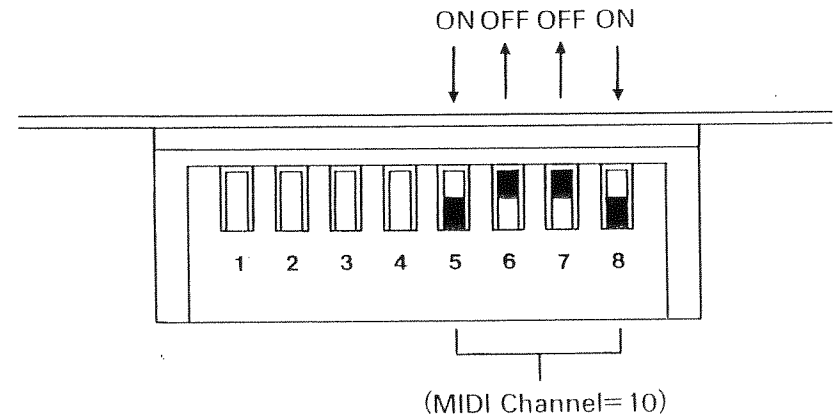

2. PLAYING A RHYTHM MACHINE

When all the connections are made, turn the unit on.
(Please handle the Power Switch gently.)

If any sound is generated by hitting the pad, adjust the sensitivity of the pad by rotating the Sens Knob. Clockwise rotation increases the sensitivity. Carefully adjust it as you actually listen to the sound.

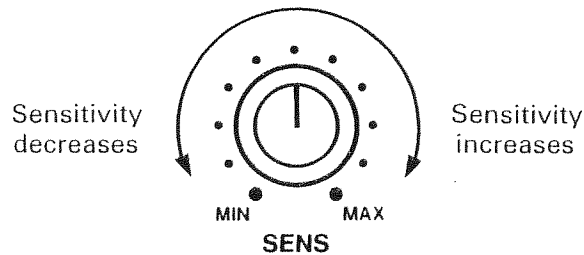

If no sound is generated by hitting the pad, set the Sens Knob from the center to MAX, then take the following procedure.

a. Sound Set 1 (Using the Value Knob)

The MPD-4 allows to select which sound of the drum machine to be played with the pad.

* On Roland TR-707 and TR-505, Open Hi-hat is selected at the manufacturer.

① Push the Sound Set Button.

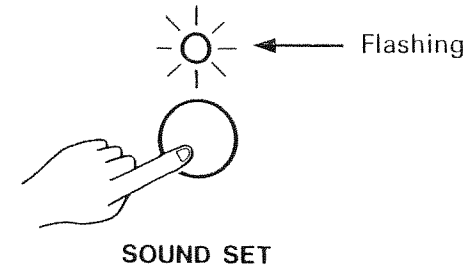

② Hit the pad of the MPD-4.

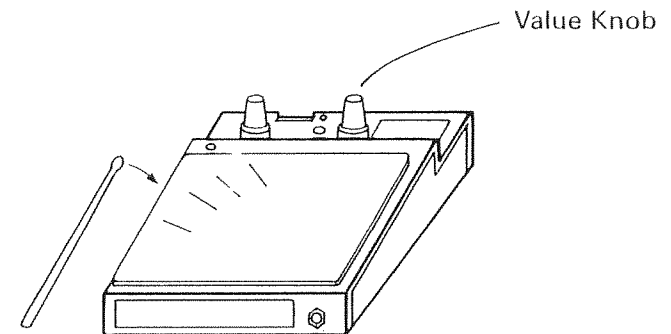

The sound currently selected is played.

* During Sound Set operation, the dynamics of a pad does not work, therefore the volume does not change whether you hit the pad hard or soft.

- ③ As you hit the pad of the MPD-4, select the sound to be played by rotating the Value Knob.

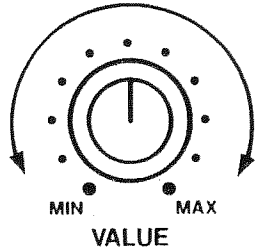

- ④ When you have selected the sound you want, push the Sound Set Button.

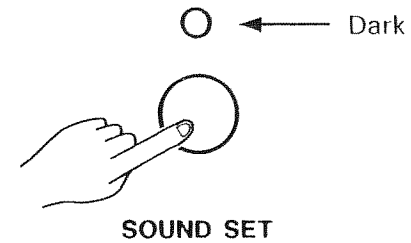

- * Please rotate the Value Knob as slowly as possible.
- * No sound may be produced if you move the Value Knob too quickly.
- * Sounds may change even without touching the Value Knob, but there is nothing to be worried about, simply reselect the sound you want.

- * The sound you select here is erased when the unit is turned off.

b. Sound Set 2 (Using MIDI IN)

In this method, the Sound Set can be quickly done, as the Instrument Keys on the rhythm machine can be used for selecting sounds.

After making the basic connections, connect the MIDI OUT of the rhythm machine to the MIDI IN of the MPD-4.

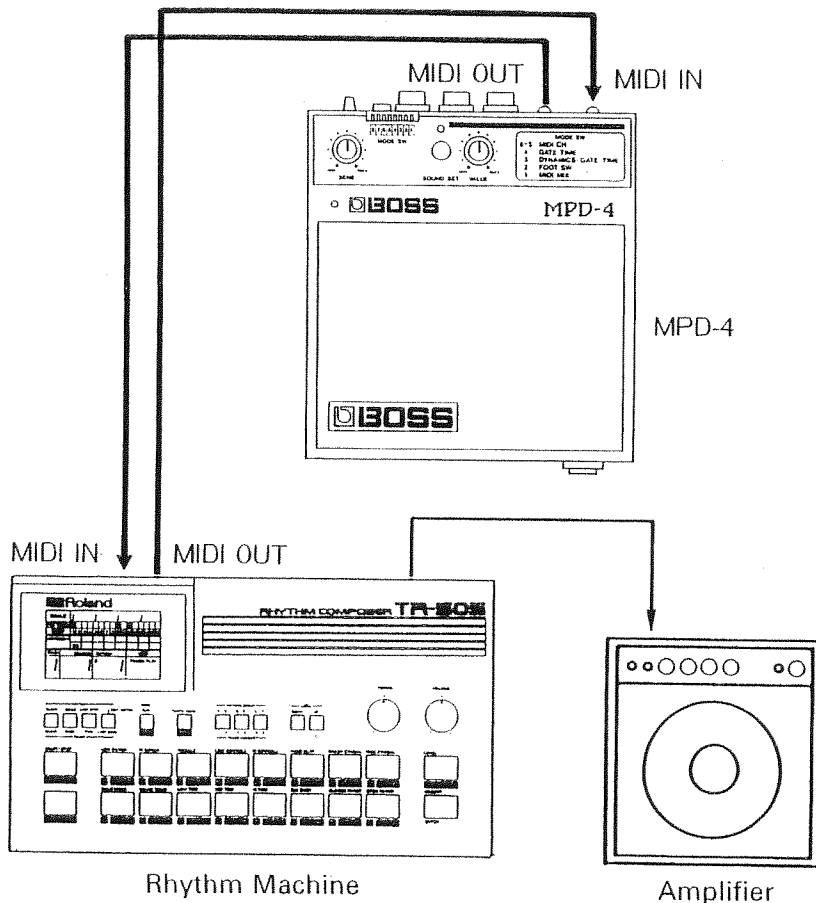

① Push the Sound Set Button.

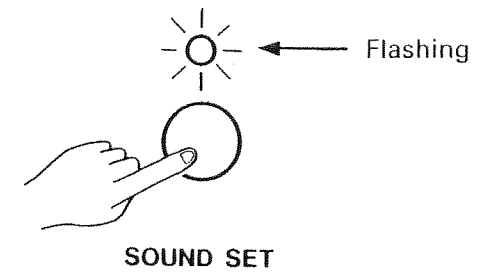

② Hit the pad of the MPD-4.

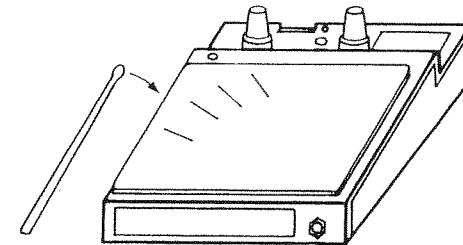

The sound currently selected is played.

* During Sound Set operation, the dynamics of a pad does not work, therefore the volume does not change whether you hit the pad hard or soft.

- ③ Push the Instrument Key that corresponds to the drum sound you want.

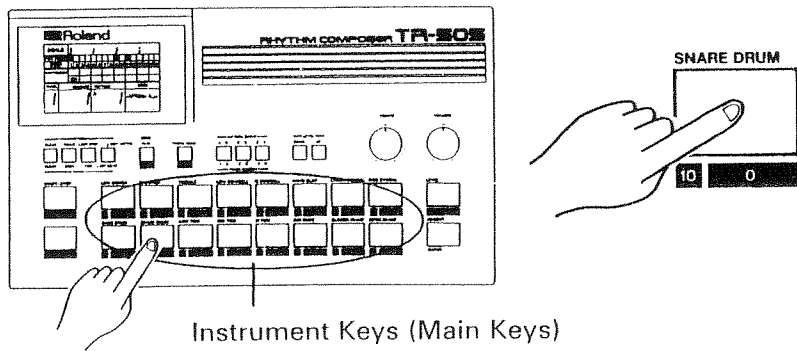

- ④ Hit the pad once more to make sure that the right sound is selected.

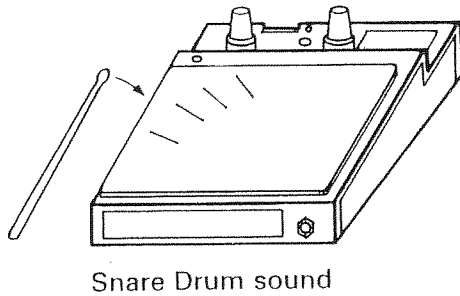

- ⑤ Push the Sound Set Button.

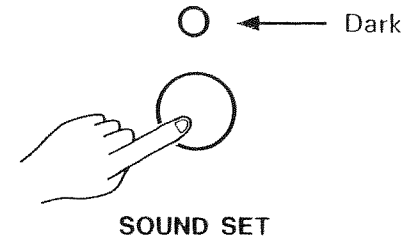

- * The sound set here is erased when the unit is turned off.

3. PLAYING THE OTHER SOUND SOURCE

The MPD-4 can use, as a sound source, a MIDI synthesizer or sampling keyboard as well as a rhythm machine. Also, the pitch can be set in semi-tone steps, therefore melody can be played by using the external pads (see page 18).

* When using the MIDI sound source other than a rhythm machine, you need to set an appropriate gate time. (Some sounds may not sound at all, unless the gate time is set rather long.)

When all the connections are made, turn the unit on. (Please handle the Power Switch gently.)

Now, adjust the sensitivity of the MPD-4's pad by rotating the Sens Knob. Clockwise rotation increases the sensitivity. Carefully adjust it as you actually listen to the sound.

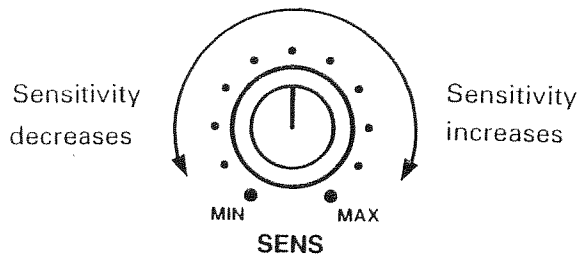

* If the sound source unit does not feature dynamics function, the dynamics on the pad does not function.

a. Sound Set 1 (Using the Value Knob)

Set which pitch is to be played by the pad.

① Push the Sound Set Button.

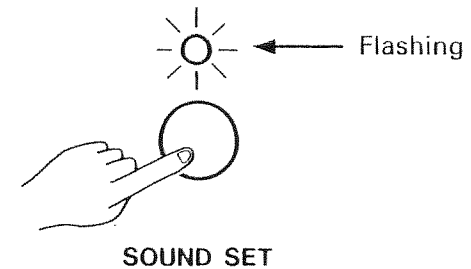

② Hit the MPD-4's pad.

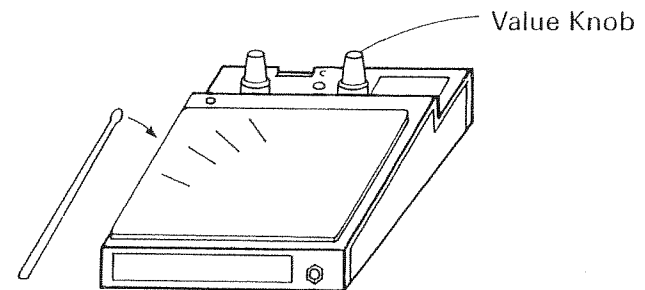

The pitch currently set is played.

* During Sound Set operation, the dynamics of a pad does not work, therefore the volume does not change whether you hit the pad hard or soft.

- ③ As you hit the pad of the MPD-4, select the pitch to be played by rotating the Value Knob.

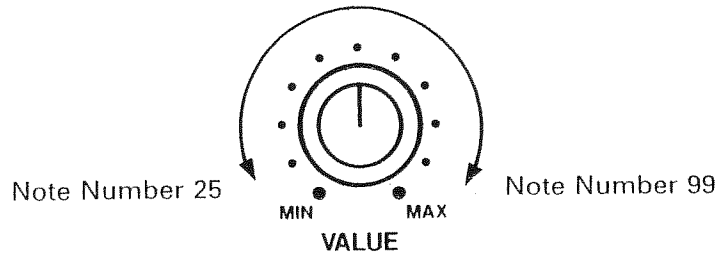

- * Please rotate the Value Knob as slowly as possible.
 - * Each time the pad is hit, the MPD-4's MIDI OUT sends the note number (25 to 99) depending on the position of the Value Knob.
- ④ When you have selected the pitch you want, push the Sound Set Button.

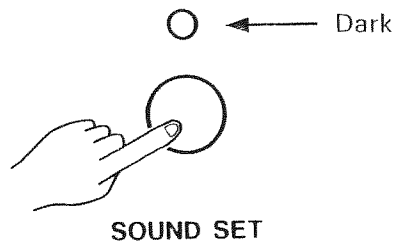

- * The sound you select here is erased when the unit is turned off.

b. Sound Set 2 (Using MIDI IN)

After making the basic connections, connect the MIDI OUT of the MIDI device to the MIDI IN of the MPD-4.

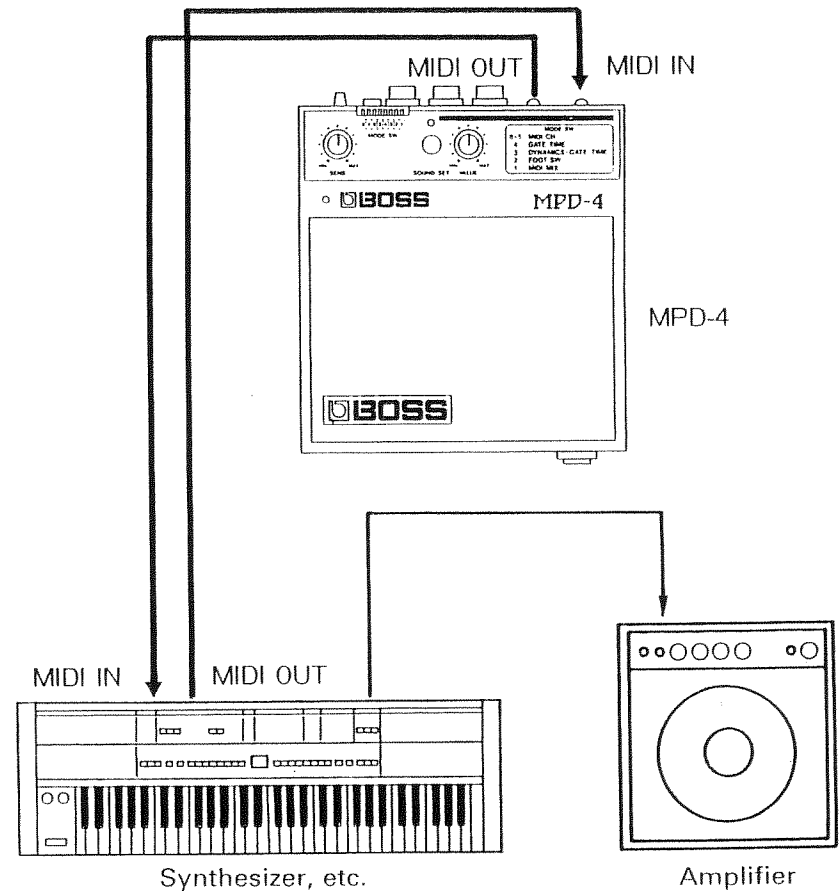

① Push the Sound Set Button.

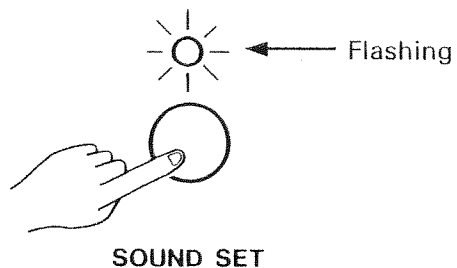

② Hit the pad of the MPD-4.

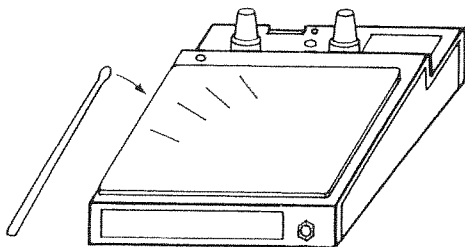

The pitch currently selected is played.

* During Sound Set operation, the dynamics of a pad does not work, therefore the volume does not change whether you hit the pad hard or soft.

③ Play the key that corresponds to the pitch you want.

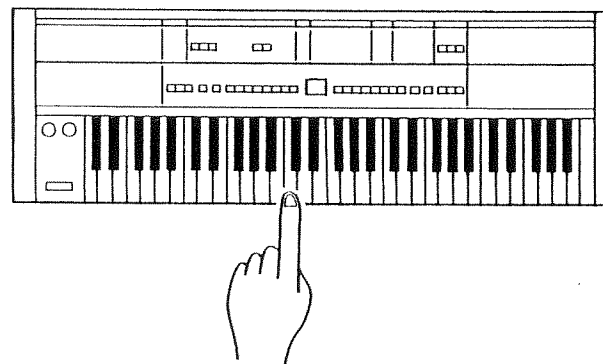

④ Hit the pad once more to make sure that the right pitch is set.

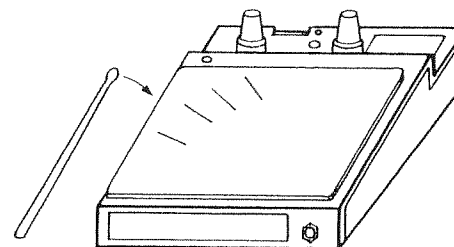

⑤ Push the Sound Set Button.

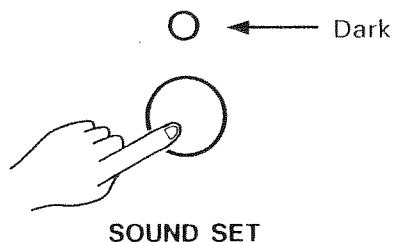

* The sound set here is erased when the unit is turned off.

c. Adjusting Gate Time

The MPD-4 can control the actual sounding time (gate time of the sound) when it is connected with a synthesizer or a sampling keyboard.

«Adjusting the gate time with the Value Knob»

① Set the Mode Switch 4 to ON.

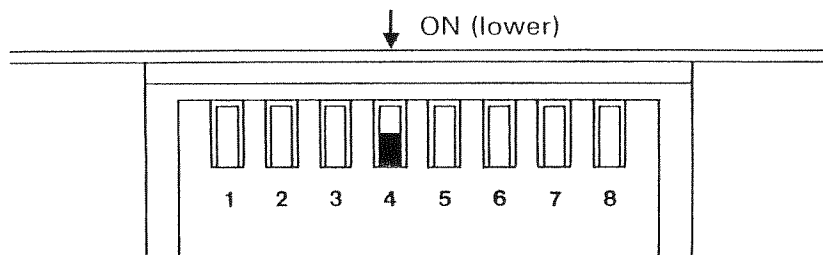

* When the Mode Switch 4 is set to OFF, the gate time is the shortest.

② Set the gate time by rotating the Value Knob.

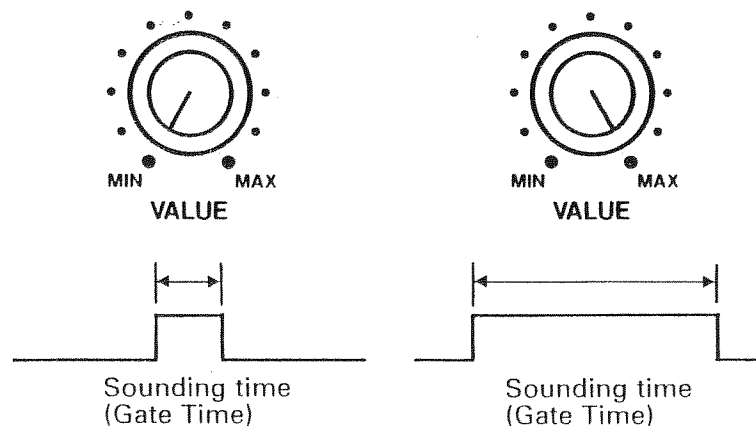

* When the Mode Switch 4 is set to the ON position, the Value Knob always functions for adjusting the gate time except for in Sound Set mode.

«Dynamic Control»

The MPD-4 allows to control the gate time by how hard the pad is hit. Hitting the pad harder will make the gate time longer.

① Set the Mode Switch 3 to ON.

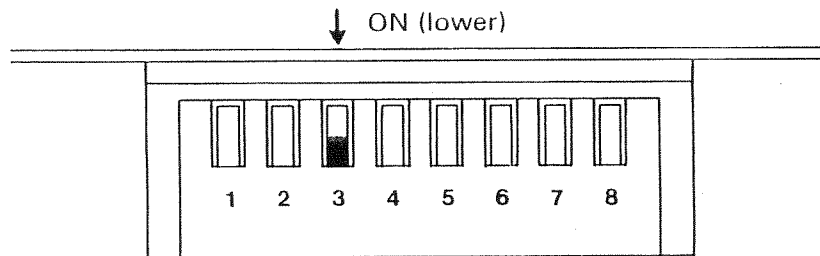

- * Here, the Value Knob cannot be used for gate time adjustment.
- * When the Mode Switches 3 and 4 are simultaneously ON, the Mode Switch 3 (dynamics control) will have priority.

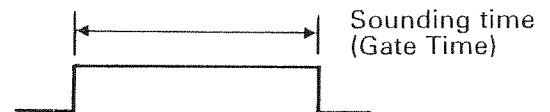
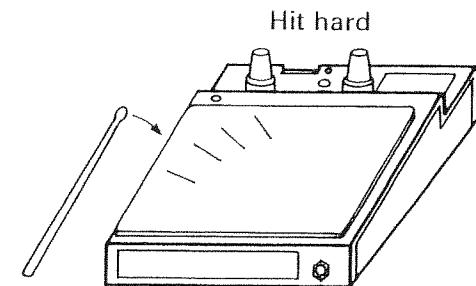
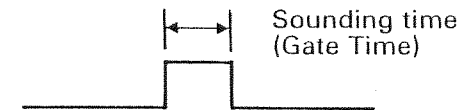
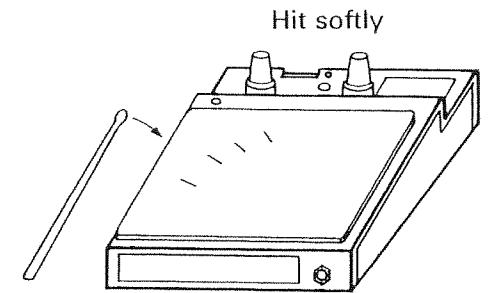

4. HOW TO USE THE FOOTSWITCH

Using the optional footswitch such as FS-5U, the MPD-4 can select two different sounds. There are two modes for using the footswitch; Hi-hat Pedal mode and Shift mode.

a. Sound setting when using a Footswitch

When a footswitch is used, two different sounds can be set; one can be set by hitting the pad without pressing the footswitch, and another one can be set by hitting the pad while holding the footswitch down. The sound set by holding the footswitch down can be played by hitting the pedal while holding the footswitch down, and vice versa.

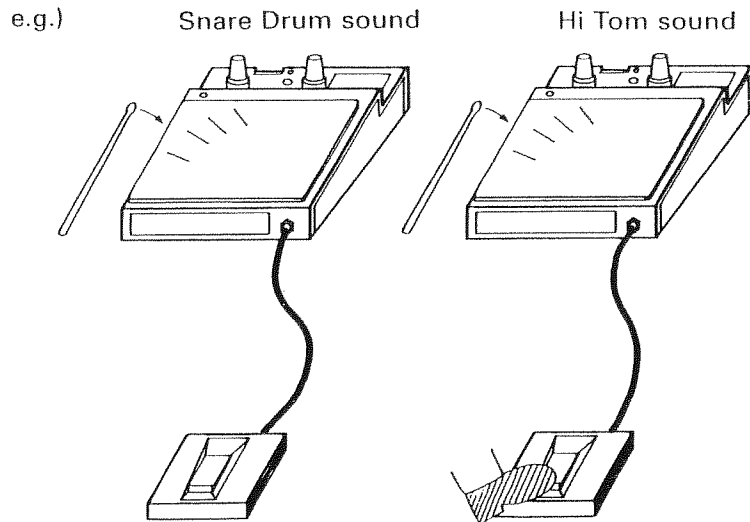

- * To set the two sounds on the device connected to the MIDI IN, press the relevant instrument key or key on the keyboard instead of hitting the pad. In this case, be sure to hold the footswitch down until the instrument key or the key on the keyboard is released. Otherwise, the set sound will be the one without pressing the footswitch.

b. Hi-hat Pedal Mode

- ① Set the Mode Switch 2 to ON.

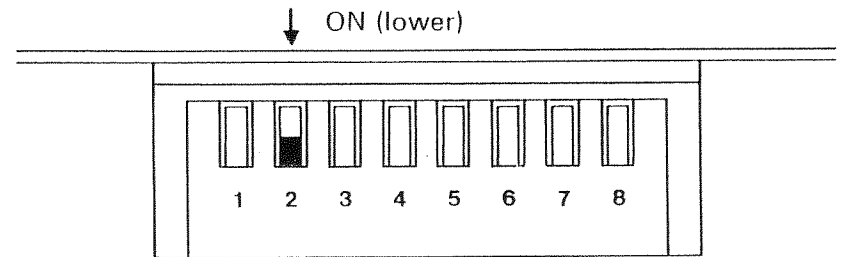

In this mode, the moment the footswitch is pressed, the sound which has been set by holding the footswitch down is played. (Naturally, the same sound will be played by holding the footswitch down.)

- * The initial volume of the sound obtained the moment the footswitch is pressed is always the same. If it is too high or low, adjust it on the sound source.

Set Open Hi-hat without pressing the footswitch, and set Closed Hi-hat while holding the footswitch down, and you can use the footswitch just like the hi-hat pedal of a drum kit.

e.g.)

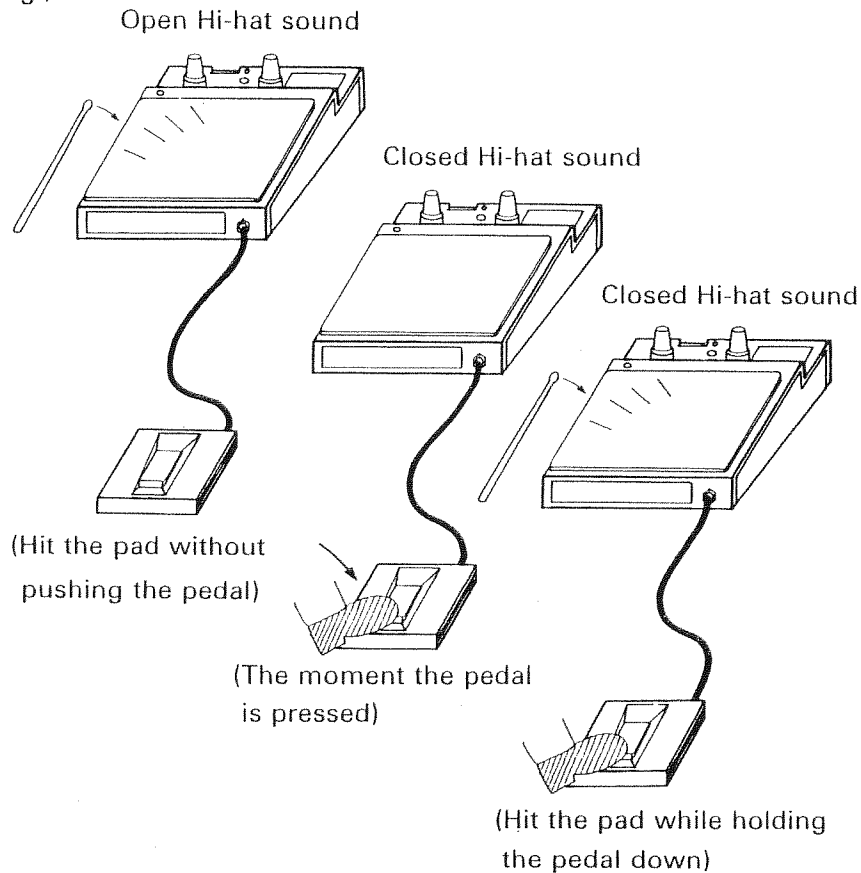

It may also be interesting to set Bass drum by pressing the footswitch.

c. Shift Mode

① Set the Mode Switch 2 to OFF.

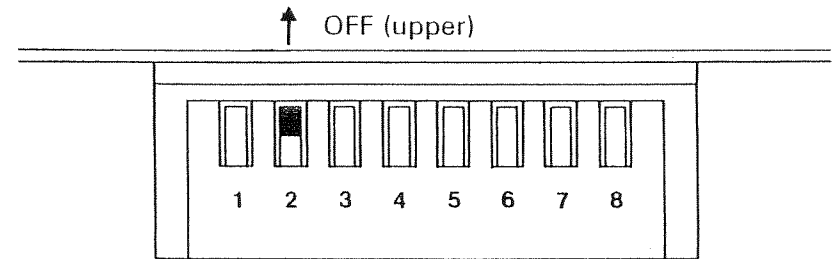

The moment the footswitch is pushed, no sound is played. (Sound is obtained by hitting the pad while holding the footswitch down.)

e.g.)

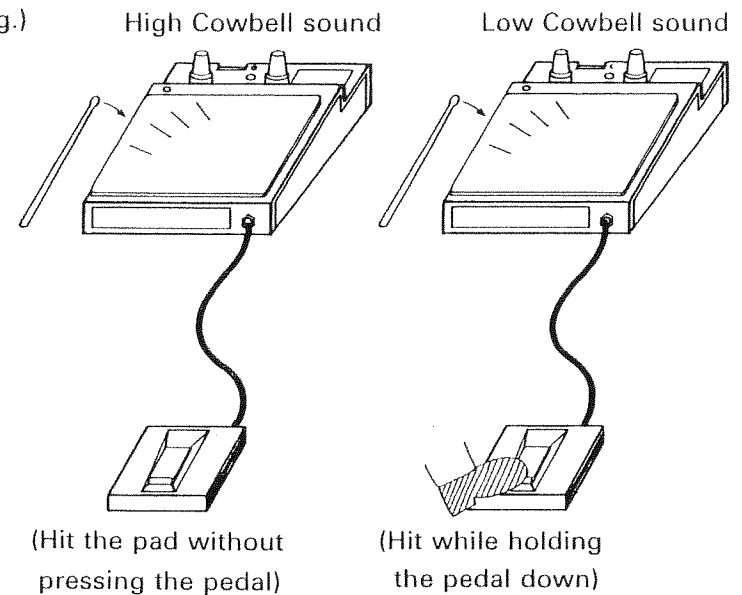

5. EXTERNAL PADS

Up to three external pads can be used together with the MPD-4. Ideal external pads for the MPD-4 are Pad Controllers BP-1's (optional). Other can also be used, but the dynamics of the pads may not be optimum.

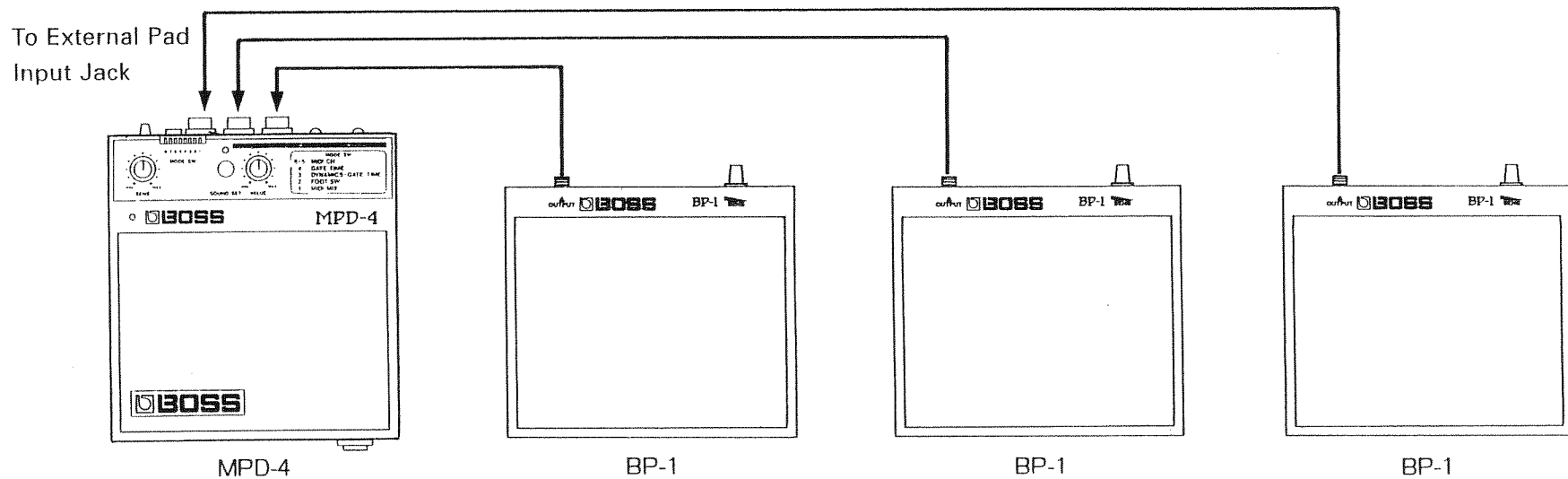

External pads can select sounds freely just like the MPD-4's pad. For Sound Set, simply hit the pad on which you wish to set sounds first, then take the sound setting procedure. To set the sound to be played by hitting the pad while holding the footswitch down, hit the relevant pad while holding the footswitch down first, then go to the sound setting procedure.

* For setting a sound on the external pad while holding the footswitch down, or playing the sound of the external pad by pressing the footswitch, first set the MPD-4 to the Shift Mode (=set the Mode Switch 2 OFF). In the Hi-hat Pedal mode, the above sound setting cannot be done.

With three external pads and a footswitch simultaneously used, the following performance can be achieved.

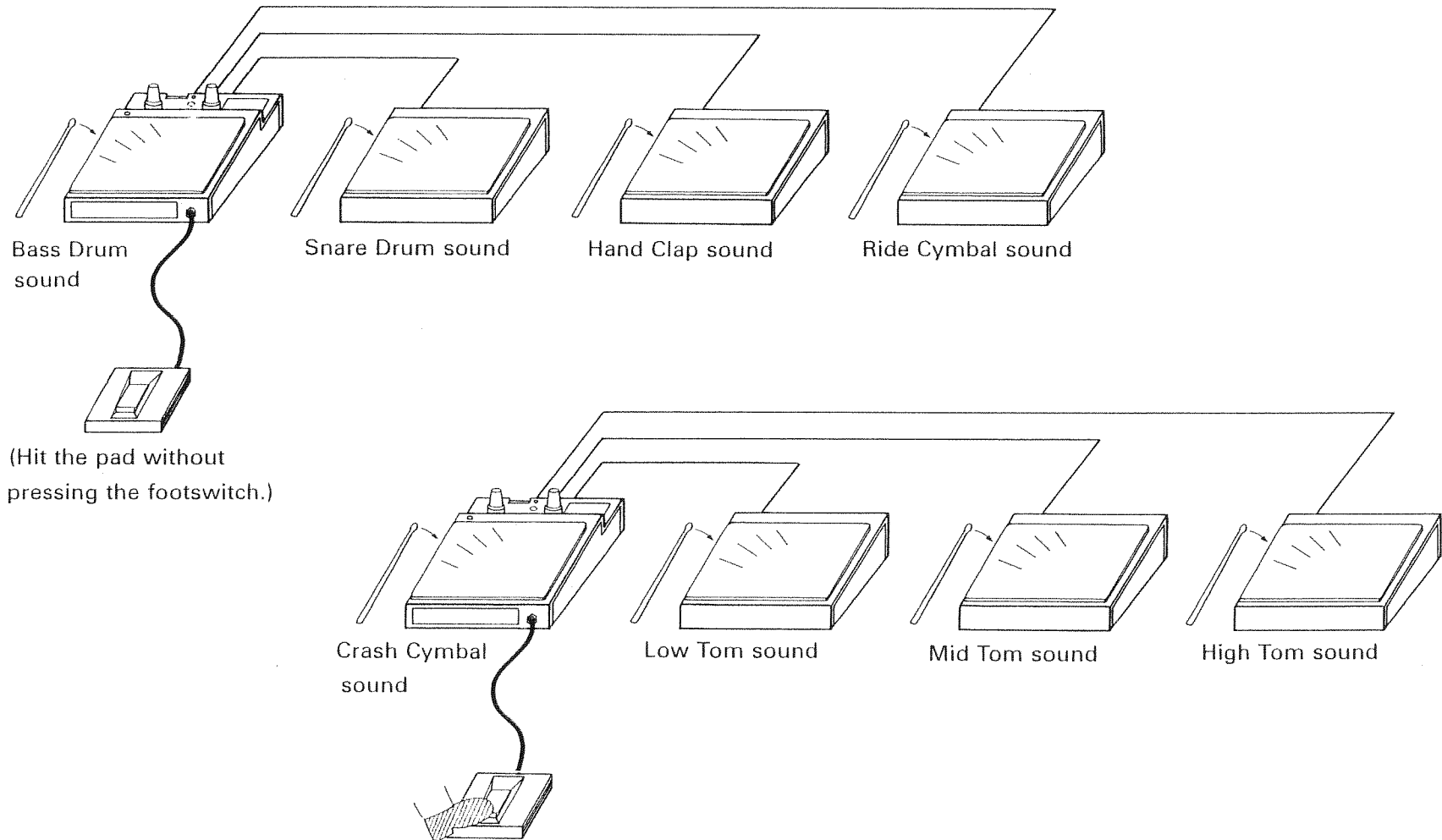

* At the MPD-4 power-up, the pad of the MPD-4 and the external pads default to the preset sounds (key numbers). When using the TR-707 or the TR-505 as a sound source, each pad is set as follows.

Preset Note Numbers

Footswitch Pad	Not pressed	Pressed
	MPD-4	Open hi-hat (Note Number 46)
External 1	Snare Drum (Note Number 38)	High Tom (Note Number 48)
External 2	Hand Clap (Note Number 39)	Mid Tom (Note Number 45)
External 3	Ride Cymbal (Note Number 51)	Low Tom (Note Number 41)

6. INSTALLING THE TOM STAND

Using the Pad Holder BPH-2 (optional), the MPD-4 and the external pads can be installed on the Tom Stand.

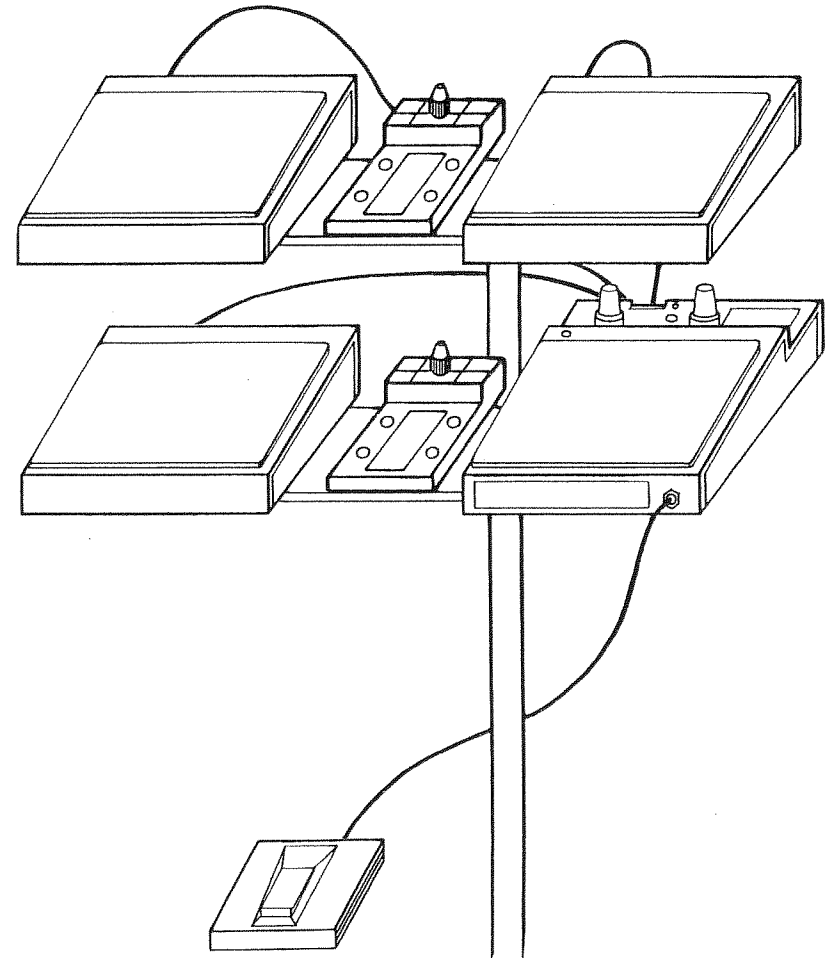

7. OTHER USEFUL FUNCTIONS

When the Mode Switch 1 is set to ON, the messages fed into the MIDI IN are mixed with the messages created in the MPD-4, and the mixed messages are sent through the MIDI OUT.

This mode is effective when using two sets of the MPD-4's.

- * In any other situation, be sure to set the Mode Switch 1 to OFF.
- * Please move the position of the Mode Switch 1 to ON to OFF while the MIDI sound module connected to the MPD-4 is not sounding.

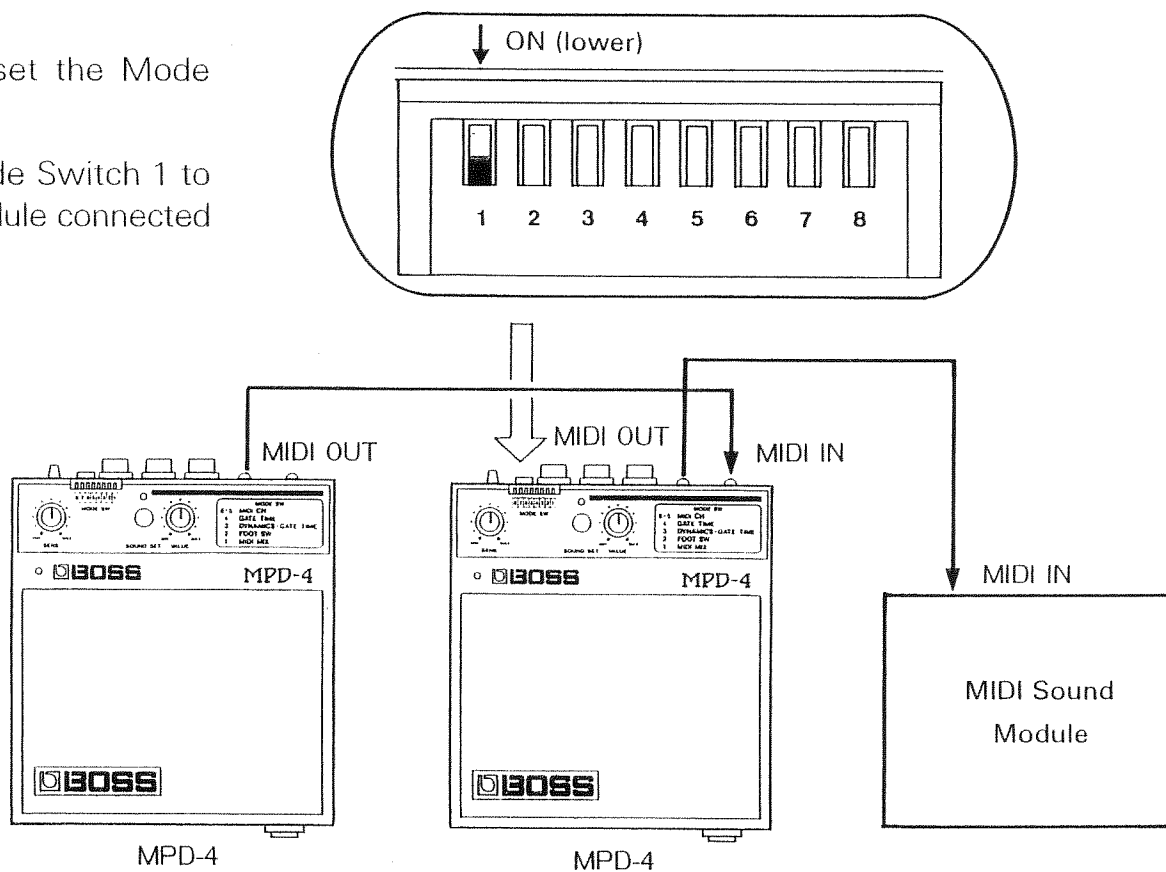

4 BATTERY REPLACEMENT

The battery lasts around two hours. This varies depending on how you use the unit or what kind of battery is used. When the Power Indicator lights dimly or the operation of the MPD-4 gets unstable, replace the battery with a new one.

■ How to replace the battery

Use one 9V battery.

① Remove the cover from the bottom of the unit.

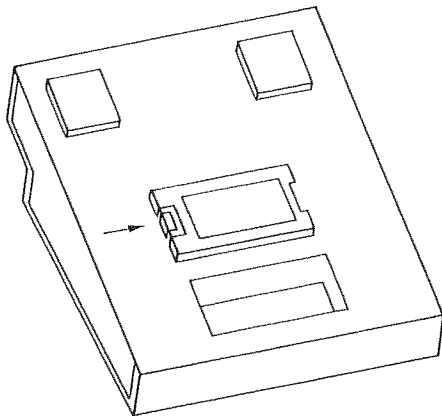

② Take out the exhausted battery from the battery housing and disconnect it from the snap cord.

③ Connect the new battery to the snap cord with care that polarity of the battery is correct.

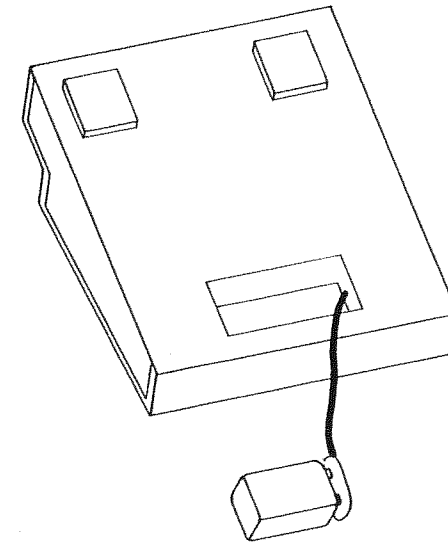

④ Place the battery in the battery housing and replace the cover.

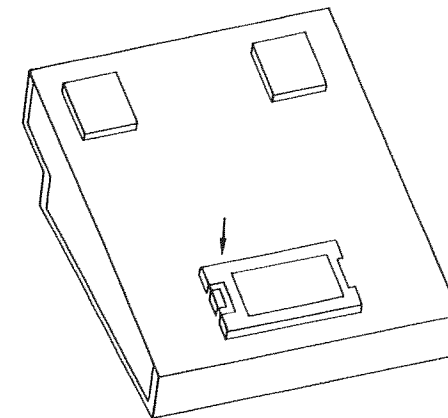

5 WHEN YOUR MPD-4 IS IN TROUBLE

No sound is heard by hitting the pad.

- **Check if the Sens Knob is not turned fully counterclockwise.**
Rotate Sens Knob clockwise.
- **Check if the connections are correctly made.**
Specially check the connections of the MIDI IN and MIDI OUT.
- **Check if the battery is not flat.**
For long and secured operation, the AC adaptor may not used.
- **Check if the volumes of the MIDI sound source and amplifier are set sufficiently high.**
- **Check if the MIDI channels of the MIDI sound source and the MPD-4 are set to the same number.**
If not, set them to the same channel number.
- **Check if the note numbers correctly correspond with the ones on the MIDI sound source.**
When using a rhythm machine, the note numbers set on the pad should correspond to the key numbers on the rhythm machine. Otherwise, no sound will be played. Set the note numbers as explained on page 7 to 10.

- **Check if the set gate time is sufficiently long.**
When using a synthesizer, it is important to set the gate time of some sounds fairly long, specially slow attack sound such as strings.

Sensitivity of each pad is different.

When using Pad Controllers BP-1's as external pads of the MPD-4, adjust the sensitivity with each Sens Knob.

- * Depending on the nature of sounds, the sensitivity varies.

The sound of the MIDI sound source does not stop.

Turn the MPD-4 and the MIDI sound source off once, and turn them on again.

The MPD-4 does not work properly because of external vibration.

Turn down the sensitivity of the pad by rotating the Sens Knob counterclockwise.

6 SPECIFICATIONS

Power: 9VDC Dry battery (× 1)
or AC Adaptor BOSS PSA-120, 220 or 240

Current Draw: 30mA (9VDC)

Controls: Sens
Value

Switches: MIDI Channel
Gate Time
Dynamics — Gate Time
Footswitch
MIDI Mix

Button: Sound Set

Jacks and Connectors: MIDI OUT
MIDI IN
External Pad 1 to 3
Footswitch
9VDC IN (AC Adaptor)

Dimensions: 152 (W) × 172 (D) × 60 (H) mm
6" × 6¾" × 2⅜"

Weight: 1100g/2lb 7oz (including the battery)

OPTIONS: AC Adaptor (BOSS PSA-120, 220 or 240)
Power Supply (RPW-7)
Pad Controller (BP-1)
Footswitch (FS-5U)
Pad Holder (BPH-2)

* Specifications are subject to change without notice.

Roland®

10415

UPC 10415



10991

MPPD-4

 **BOSS**

Products of Roland

'87-Mar-E-3-1