

 Roland®

GK-2A-KIT

Owner's Manual

Roland Synthesizer Driver GK-2A-KIT Owner's Manual

Thank you for purchasing the Roland GK-2A-KIT, a sophisticated guitar pickup and dedicated synthesizer control system.

When properly installed, the GK-2A-KIT can turn virtually any electric guitar into a controller for Roland's GR Guitar Synthesizers or Roland's V•Guitar System.

To ensure proper installation – which is critical – and operation, please read this owner's manual carefully.

- Wherever [GR] is mentioned in this manual, it refers to either the Roland Guitar Synthesizer or the Roland V•Guitar System.

Before using this unit, carefully read the sections entitled: "USING THE UNIT SAFELY" and "IMPORTANT NOTES." These sections provide important information concerning the proper operation of the unit. Additionally, in order to feel assured that you have gained a good grasp of every feature provided by your new unit, this manual should be read in its entirety. The manual should be saved and kept on hand as a convenient reference.



Copyright © 1997 ROLAND CORPORATION

All rights reserved. No part of this publication may be reproduced in any form without the written permission of ROLAND CORPORATION.







USING THE UNIT SAFELY

INSTRUCTIONS FOR THE PREVENTION OF FIRE, ELECTRIC SHOCK, OR INJURY TO PERSONS

About WARNING and CAUTION Notices



 WARNING	Used for instructions intended to alert the user to the risk of death or severe injury should the unit be used improperly.
 CAUTION	Used for instructions intended to alert the user to the risk of injury or material damage should the unit be used improperly. <ul style="list-style-type: none"> • Material damage refers to damage or other adverse effects caused with respect to the home and all its furnishings, as well to domestic animals or pets.

About the Symbols



	The  symbol alerts the user to important instructions or warnings. The specific meaning of the symbol is determined by the design contained within the triangle. In the case of the symbol at left, it is used for general cautions, warnings, or alerts to danger.
	The  symbol alerts the user to items that must never be carried out (are forbidden). The specific thing that must not be done is indicated by the design contained within the circle. In the case of the symbol at left, it means that the unit must never be disassembled.
	The  symbol alerts the user to things that must be carried out. The specific thing that must be done is indicated by the design contained within the circle. In the case of the symbol at left, it means that the power-cord plug must be unplugged from the outlet.

ALWAYS OBSERVE THE FOLLOWING

WARNING

- Before using this unit, make sure to read the instructions below, and the Owner's Manual. 
- Do not attempt to repair the unit, or replace parts within it (except when this manual provides specific instructions directing you to do so). Refer all servicing to your dealer, or qualified Roland service personnel. 

WARNING

- Never use or store the unit in places that are: 
 - Subject to temperature extremes (e.g., direct sunlight in an enclosed vehicle, near a heating duct, on top of heat-generating equipment); or are
 - Damp (e.g., baths, washrooms, on wet floors); or are
 - Humid; or are
 - Dusty; or are
 - Subject to high levels of vibration.
- Protect the unit from strong impact. (Do not drop it!) 

Parts and Connection

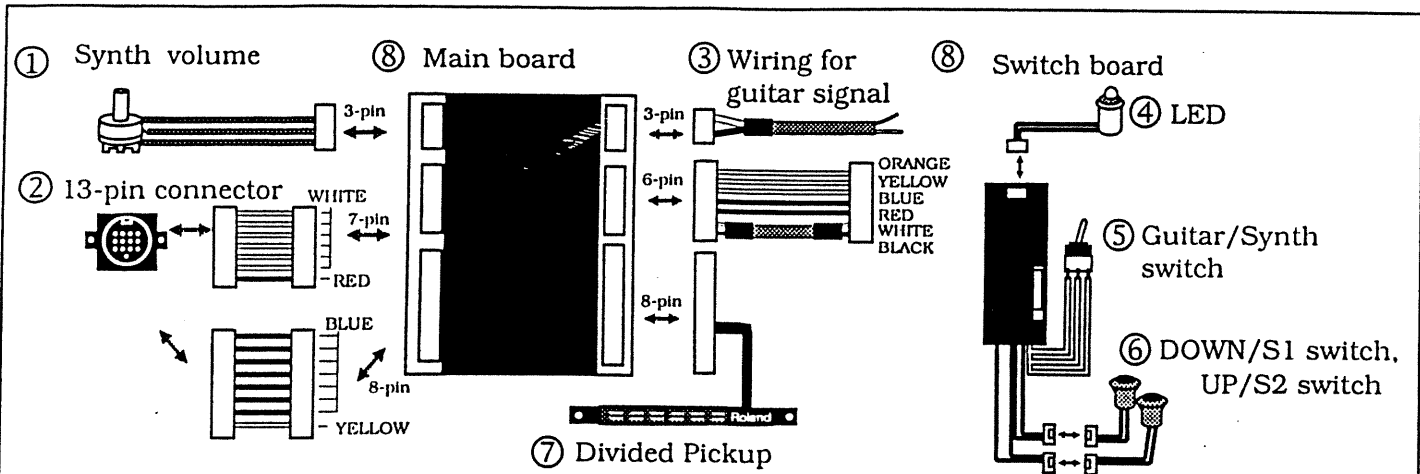

Supplied parts contents

Plate parts set

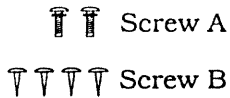
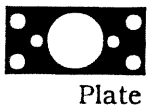

Divided Pickup parts set

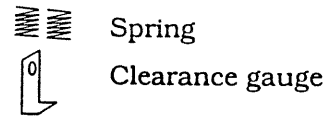
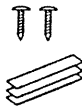

Attach each part to the guitar.

① Synth volume

Drill the guitar and mount the synth volume with the attached nuts and washers.

scale 1:1

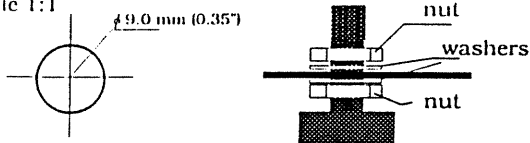

If the volume shaft is too short, please try only with the nuts, without the washers.

③ Wiring for guitar signal

Transferring the guitar signal to the guitar output on the GR unit via 13-pin cable. Solder the white wire to the guitar signals and uncovered wire (silver) to the earth(ground) of the guitar.

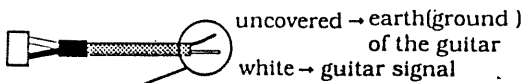

Short these wires together if you choose not to send the guitar signal through the GK-2A-Kit to the GR unit.

Be careful not to burn the guitar or other wirings.

② 13-pin connector

Drill the guitar and attach the connector with the supplied screws and plate.

scale 1:1

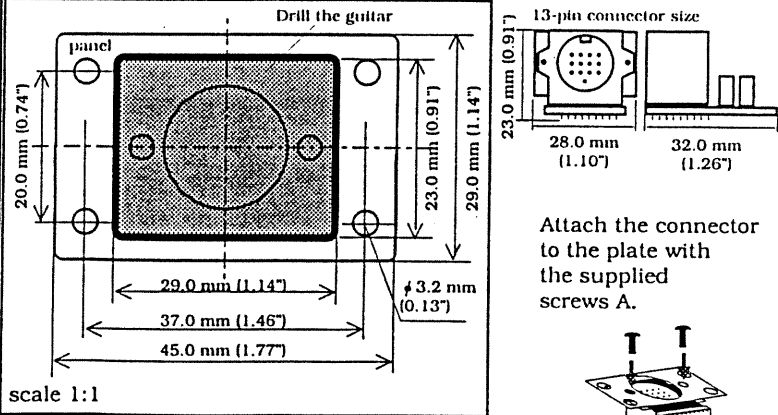

Attach the connector to the plate with the supplied screws A.

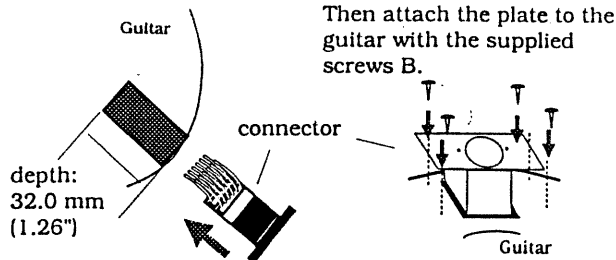
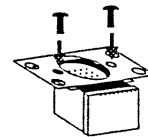

④ LED

Drill the guitar, insert the LED and then connect the wiring.

scale 1:1

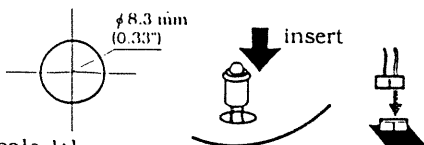

⑤ Guitar/Synth switch

Drill the guitar, and mount the switch with the attached nuts and washers.

scale 1:1

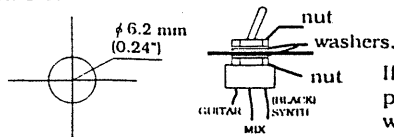

If the screw shaft is too short, please try only with the nuts, without the washers.

⑥ DOWN/S1 switch, UP/S2 switch

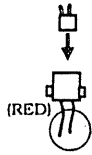
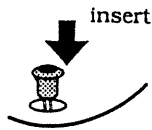

Drill the guitar, insert the switch, then connect the wiring to the switch. This is a friction fitting - be precise with your drill bit size and insert the switch firmly.

Red wiring is for DOWN/S1 switch.

⑦ Divided Pickup

Place the Divided Pickup in the appropriate position. Carefully mark the location of the screw holes (at either end of the Pickup) on the guitar.

*Check the pickup position by centering the GK-2A poles under the guitar strings.

Very carefully drill holes at the marked locations. The holes should be about 2 mm (0.08") in diameter and approximately 2mm (0.08") to 3 mm (0.12") deep. If the guitar is made of a hard wood (maple, rock maple, cherry, rosewood, etc.), make the holes slightly larger than 2 mm (0.08").

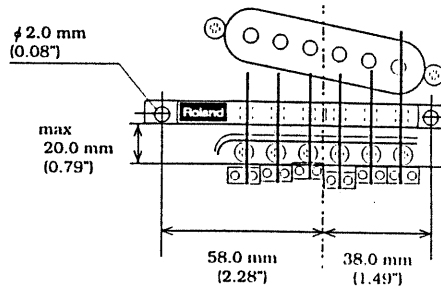

ex 1. Stratocaster type

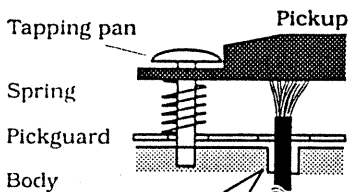

ex 2. Acoustic guitar

If the guitar body is not thick enough to fix the pickup with tapping pans, use the attached spacers.

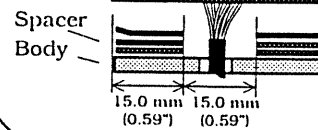

● How to use the clearance gauge.

The optimum distance between the Pickup and each string is about 1.0 mm when the highest notes on the neck are fingered. The supplied clearance gauge is 1.0 mm (0.04") thick. As shown, insert the clearance gauge between the Pickup and the strings. Adjust the Pickup height as necessary.

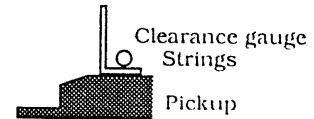

Drill the guitar to put the wire through to the pickup cavity.

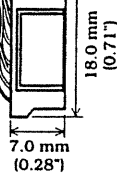
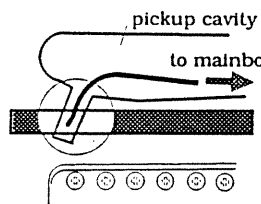

Drill the pickguard/body to put the wire through.

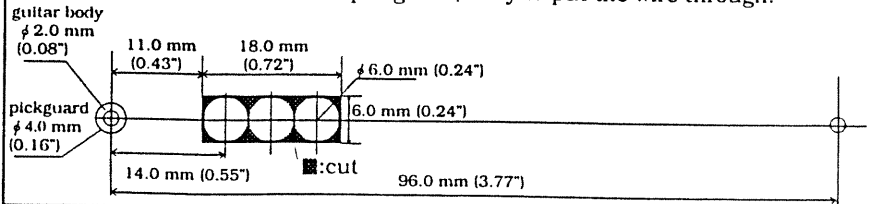

⑧ Main board and Switch board

Put the main board and switch board in the cavity inside the guitar

Note: Size and location of cavity, and wiring paths may differ by the guitar.

Connect the parts.

After attaching all the parts, connect them according to "Parts and Connection".

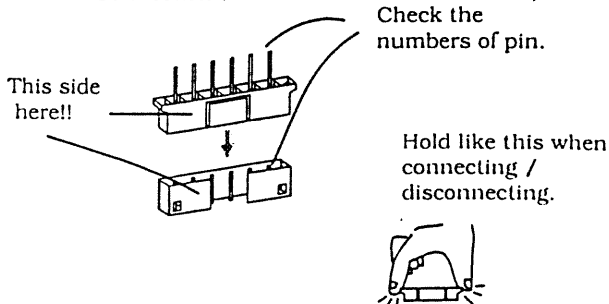

Tips

How to install the synth volume in the cavity for the guitar tone control circuit.

Guitar which has a volume and two tone controls may not have enough room for the synth volume behind the pick guard. You can install the synth volume by removing one of the original tone controls.

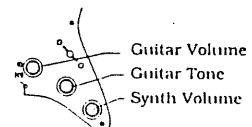

If you cannot arrange enough room for the synth volume, you can control the volume of synth sound with the GR unit, without attaching the synth volume, by using an expression pedal such as Roland EV-5 or BOSS FV-300L.

IMPORTANT NOTES

In addition to the items listed under "USING THE UNIT SAFELY," please read the following.

Attachment

- To install the GK-2A-KIT to the guitar, you will need to have basic electronic construction, soldering and woodworking skills and associated tools such as an appropriate soldering iron, drill and assorted drill bits. Please contact your retailer if you have difficulty performing the installation.
- Roland assumes no liability concerning any damage to the guitar and GK-2A-KIT upon installing the GK-2A-KIT. Please proceed with the installation using caution and care at your own risk.

Cautions for installation

- To avoid the risk of damage to internal components that can be caused by static electricity, please carefully observe the following whenever you handle the board.
 1. Before you touch the board, always first grasp a metal object (such as a water pipe), so you are sure that any static electricity you might have been carrying has been discharged.
 2. When handling the board, grasp it only by its edges. Avoid touching any of the electronic components or connectors.

Sensitivity Adjustment

- To properly drive the [GR] with the GK-2A-KIT, you must adjust the height of the Divided Pickup and the sensitivity of the [GR]. These adjustments are very important if you want to take full advantage of the [GR]'s superior tracking ability. Please read the GK-2A-KIT and [GR] owner's manuals.

C-13A/B cable

- Be sure to use the C-13A/B cable to connect the GK-2A-KIT to the [GR]. Using any other cable may cause unnecessary problems.
- The C-13A/B is a locking-type cable which cannot be disconnected unless it is unlocked.

- Before playing, be sure to wrap the cable around the guitar strap near the strap hook. This will eliminate any unnecessary strain on the cable or the GK-2A-KIT.

Divided Pickup

- To avoid damage, be sure there is no unnecessary strain on the cable that connects the Pickup and the Controller.
- Never bend, twist or otherwise place undue pressure on the Pickup. Be especially careful when removing it. Also, make sure no force is applied to the 'yokes.'

Additional Precautions

- Before setting up the GK-2A-KIT with the [GR], turn the [GR] off.

Installation

Before installing the GK-2A-KIT, read the following "INSTALLATION NOTES."

INSTALLATION NOTES

- Even when properly installed, the GK-2A-KIT will not work with 12-string guitars, guitars with unusual or customized string setups, nylon-string guitars, gut-string guitars, or bass guitars.
- If your guitar has a tremolo arm (whammy bar), attach the arm before setting up the GK-2A-KIT.
- Adjust the neck (truss rod) and the height of the strings if necessary before installing the GK-2A-KIT.
- Try placing the Divided Pickup on the guitar to see if they are compatible before actually attaching them.
- If there is no room for the Divided Pickup between the guitar's bridge pickup and the bridge itself, you would be better off modifying your guitar. (If possible, move the bridge pickup closer to the neck to make room for the Divided Pickup.)

Roland®

10702

UPC

10702



10981

Roland®