



F-100 Digital Piano

Owner's Manual

Congratulations on your choice of the Roland Digital Piano F-100.

Before using this unit, carefully read the sections entitled: **“USING THE UNIT SAFELY”** and **“IMPORTANT NOTES”** (p. 2; p. 4). These sections provide important information concerning the proper operation of the unit. Additionally, in order to feel assured that you have gained a good grasp of every feature provided by your new unit, Owner's manual should be read in its entirety. The manual should be saved and kept on hand as a convenient reference.

Assembling the F-100		page 6
Before You Play		page 10
Listening to the Internal Songs		page 13
Playing the Keyboard		page 15
Contents		page 9
Index		page 39

IMPORTANT: THE WIRES IN THIS MAINS LEAD ARE COLOURED IN ACCORDANCE WITH THE FOLLOWING CODE.

BLUE: NEUTRAL
BROWN: LIVE

As the colours of the wires in the mains lead of this apparatus may not correspond with the coloured markings identifying the terminals in your plug, proceed as follows:

The wire which is coloured BLUE must be connected to the terminal which is marked with the letter N or coloured BLACK.

The wire which is coloured BROWN must be connected to the terminal which is marked with the letter L or coloured RED.

Under no circumstances must either of the above wires be connected to the earth terminal of a three pin plug.



USING THE UNIT SAFELY

INSTRUCTIONS FOR THE PREVENTION OF FIRE, ELECTRIC SHOCK, OR INJURY TO PERSONS

About ⚠ WARNING and ⚠ CAUTION Notices

⚠ WARNING	Used for instructions intended to alert the user to the risk of death or severe injury should the unit be used improperly.
⚠ CAUTION	Used for instructions intended to alert the user to the risk of injury or material damage should the unit be used improperly. * Material damage refers to damage or other adverse effects caused with respect to the home and all its furnishings, as well to domestic animals or pets.

About the Symbols

	The ⚠ symbol alerts the user to important instructions or warnings. The specific meaning of the symbol is determined by the design contained within the triangle. In the case of the symbol at left, it is used for general cautions, warnings, or alerts to danger.
	The ⚡ symbol alerts the user to items that must never be carried out (are forbidden). The specific thing that must not be done is indicated by the design contained within the circle. In the case of the symbol at left, it means that the unit must never be disassembled.
	The ⚡ symbol alerts the user to things that must be carried out. The specific thing that must be done is indicated by the design contained within the circle. In the case of the symbol at left, it means that the power-cord plug must be unplugged from the outlet.



ALWAYS OBSERVE THE FOLLOWING

⚠ WARNING

- Before using this unit, make sure to read the instructions below, and the Owner's Manual. 



- Do not open (or modify in any way) the unit or its AC adaptor. 

- Do not attempt to repair the unit, or replace parts within it (except when this manual provides specific instructions directing you to do so). Refer all servicing to your retailer, the nearest Roland Service Center, or an authorized Roland distributor, as listed on the "Information" page. 

- Never use or store the unit in places that are:
 - Subject to temperature extremes (e.g., direct sunlight in an enclosed vehicle, near a heating duct, on top of heat-generating equipment); or are 
 - Damp (e.g., baths, washrooms, on wet floors); or are 
 - Humid; or are
 - Exposed to rain; or are
 - Dusty; or are
 - Subject to high levels of vibration.

⚠ WARNING









- Make sure you always have the unit placed so it is level and sure to remain stable. Never place it on stands that could wobble, or on inclined surfaces. 

- Be sure to use only the AC adaptor supplied with the unit. Also, make sure the line voltage at the installation matches the input voltage specified on the AC adaptor's body. Other AC adaptors may use a different polarity, or be designed for a different voltage, so their use could result in damage, malfunction, or electric shock. 



- Use only the attached power-supply cord. 

- Do not excessively twist or bend the power cord, nor place heavy objects on it. Doing so can damage the cord, producing severed elements and short circuits. Damaged cords are fire and shock hazards! 











⚠ WARNING

- This unit, either alone or in combination with an amplifier and headphones or speakers, may be capable of producing sound levels that could cause permanent hearing loss. Do not operate for a long period of time at a high volume level, or at a level that is uncomfortable. If you experience any hearing loss or ringing in the ears, you should immediately stop using the unit, and consult an audiologist. 
- Do not allow any objects (e.g., flammable material, coins, pins); or liquids of any kind (water, soft drinks, etc.) to penetrate the unit. 

- Immediately turn the power off, remove the AC adaptor from the outlet, and request servicing by your retailer, the nearest Roland Service Center, or an authorized Roland distributor, as listed on the "Information" page when:

 - The AC adaptor, the power-supply cord, or the plug has been damaged; or
 - Objects have fallen into, or liquid has been spilled onto the unit; or
 - The unit has been exposed to rain (or otherwise has become wet); or
 - The unit does not appear to operate normally or exhibits a marked change in performance.
- In households with small children, an adult should provide supervision until the child is capable of following all the rules essential for the safe operation of the unit. 
- Protect the unit from strong impact. (Do not drop it!) 
- Do not force the unit's power-supply cord to share an outlet with an unreasonable number of other devices. Be especially careful when using extension cords—the total power used by all devices you have connected to the extension cord's outlet must never exceed the power rating (watts/amperes) for the extension cord. Excessive loads can cause the insulation on the cord to heat up and eventually melt through. 
- Before using the unit in a foreign country, consult with your retailer, the nearest Roland Service Center, or an authorized Roland distributor, as listed on the "Information" page. 

⚠ CAUTION

- The unit and the AC adaptor should be located so their location or position does not interfere with their proper ventilation. 

⚠ CAUTION

- Always grasp only the plug on the AC adaptor cord when plugging into, or unplugging from, an outlet or this unit. 
- At regular intervals, you should unplug the AC adaptor and clean it by using a dry cloth to wipe all dust and other accumulations away from its prongs. Also, disconnect the power plug from the power outlet whenever the unit is to remain unused for an extended period of time. Any accumulation of dust between the power plug and the power outlet can result in poor insulation and lead to fire. 
- Try to prevent cords and cables from becoming entangled. Also, all cords and cables should be placed so they are out of the reach of children. 
- Never climb on top of, nor place heavy objects on the unit. 
- Never handle the AC adaptor or its plugs with wet hands when plugging into, or unplugging from, an outlet or this unit. 
- If you need to move the instrument, take note of the precautions listed below. At least two persons are required to safely lift and move the unit. It should be handled carefully, all the while keeping it level. Make sure to have a firm grip, to protect yourself from injury and the instrument from damage. 
 - Check to make sure the screws securing the unit to the stand have not become loose. Fasten them again securely whenever you notice any loosening.
 - Disconnect the power cord.
 - Disconnect all cords coming from external devices.
 - Remove the lid.
 - Remove the music stand.
- Before cleaning the unit, turn off the power and unplug the AC adaptor from the outlet (p. 10). 
- Whenever you suspect the possibility of lightning in your area, disconnect the AC adaptor from the outlet. 
- Be careful when opening/closing the lid so you do not get your fingers pinched (p. 11). Adult supervision is recommended whenever small children use the unit. 
- Should you remove the caps, screws and cord cramps, make sure to put them in a safe place out of children's reach, so there is no chance of them being swallowed accidentally. 

IMPORTANT NOTES

In addition to the items listed under “USING THE UNIT SAFELY” on page 2 and 3, please read and observe the following:

Power Supply

- Do not use this unit on the same power circuit with any device that will generate line noise (such as an electric motor or variable lighting system).
- When the AC adaptor is used for extended periods, both the adaptor itself, and the area around the F-100's DC In connector will become somewhat warm; however, this does not indicate a malfunction.
- Before connecting this unit to other devices, turn off the power to all units. This will help prevent malfunctions and/or damage to speakers or other devices.

Placement

- Using the unit near power amplifiers (or other equipment containing large power transformers) may induce hum. To alleviate the problem, change the orientation of this unit; or move it farther away from the source of interference.
- This device may interfere with radio and television reception. Do not use this device in the vicinity of such receivers.
- Noise may be produced if wireless communications devices, such as cell phones, are operated in the vicinity of this unit. Such noise could occur when receiving or initiating a call, or while conversing. Should you experience such problems, you should relocate such wireless devices so they are at a greater distance from this unit, or switch them off.
- Do not expose the unit to direct sunlight, place it near devices that radiate heat, leave it inside an enclosed vehicle, or otherwise subject it to temperature extremes. Also, do not allow lighting devices that normally are used while their light source is very close to the unit (such as a piano light), or powerful spotlights to shine upon the same area of the unit for extended periods of time. Excessive heat can deform or discolor the unit.
- To avoid possible breakdown, do not use the unit in a wet area, such as an area exposed to rain or other moisture.
- Do not allow rubber, vinyl, or similar materials to remain on the piano for long periods of time. Such objects can discolor or otherwise harmfully affect the finish.
- Do not put anything that contains water (e.g., flower vases) on the piano. Also, avoid the use of insecticides, perfumes, alcohol, nail polish, spray cans, etc., near the unit. Swiftly wipe away any liquid that spills on the unit using a dry, soft cloth.
- Do not allow objects to remain on top of the keyboard. This can be the cause of malfunction, such as keys ceasing to produce sound.

- Do not paste stickers, decals, or the like to this instrument. Peeling these off, particularly when strong adhesives have been used, can damage the instrument's exterior finish (the stickers provided with this instrument feature a weak adhesive).

Maintenance

- To clean the unit, use a dry, soft cloth; or one that is slightly dampened. Try to wipe the entire surface using an equal amount of strength, moving the cloth along with the grain of the wood. Rubbing too hard in the same area can damage the finish.
- Never use benzine, thinners, alcohol or solvents of any kind, to avoid the possibility of discoloration and/or deformation.

Additional Precautions

- Unfortunately, it may be impossible to restore the contents of data that was stored in the unit's memory once it has been lost. Roland Corporation assumes no liability concerning such loss of data.
- Use a reasonable amount of care when using the unit's buttons, sliders, or other controls; and when using its jacks and connectors. Rough handling can lead to malfunctions.
- When connecting / disconnecting all cables, grasp the connector itself—never pull on the cable. This way you will avoid causing shorts, or damage to the cable's internal elements.
- A small amount of heat will radiate from the unit during normal operation.
- To avoid disturbing your neighbors, try to keep the unit's volume at reasonable levels. You may prefer to use headphones, so you do not need to be concerned about those around you (especially when it is late at night).
- When you need to transport the unit, package it in the box (including padding) that it came in, if possible. Otherwise, you will need to use equivalent packaging materials.
- Use a cable from Roland to make the connection. If using some other make of connection cable, please note the following precautions.
 - Some connection cables contain resistors. Do not use cables that incorporate resistors for connecting to this unit. The use of such cables can cause the sound level to be extremely low, or impossible to hear. For information on cable specifications, contact the manufacturer of the cable.

Introduction

Congratulations on your choice of the Roland Digital Piano F-100.

In order to enjoy reliable performance of your new keyboard for many years to come, please take the time to read through this manual in its entirety.

Main Features

Refined Wood Grain, Compact Design

The simple design and light wood grain finish is at home both in the living room as well as in the children's room.

And at a compact about 300 millimeters deep, it fits in perfectly with other furniture.

Authentic Piano Performances

High-quality concert grand piano tones, along with the Progressive Hammer Action keyboard, which gives more realistic piano touch by providing a heavier feel in the low end and a lighter feel in the upper notes, let you enjoy truly authentic piano performances. The two pedals are securely attached to the piano, ensuring that they will be stable when operated.

High-Performance Two-Box Speaker Construction

The lateral speaker box features two independent left and right speaker boxes, providing unexpectedly superior volume and sonic quality.

The speakers can also be directed rearward if conditions require.

A variety of practice features to help you develop your musicality

In addition to a metronome, the F-100 provides functionality that is possible only for an electronic piano, making it an instrument that is ideal for piano lessons: a "rhythm function" that encourages a natural sense of rhythm, and a "two-track recorder" that lets you record and listen to your own playing.

Tones For Use in a Wide Variety of Musical Genres

The F-100 offers twenty different onboard tones, including piano, which can be used for almost every conceivable style of music.

Includes High-Quality Reverb

The Reverb effect can duplicate the ambience of a concert hall.

Sixty Internal Piano Songs

The instrument comes with a selection of classical piano songs, which can be used for lesson, or be played for your listening enjoyment.

Keyboard Touch Can Be Set to Match Finger Strength

You can change the keyboard touch so it better suits the finger strength of the person playing the keyboard.

Checking the Included Items

Check to see if you have all of the items that normally are supplied with the F-100.

If any items are missing, please contact the dealer where you purchased this unit.

- F-100 (For installing the F-100, refer to p. 6)
 - Side Panel right
 - Side Panel left
 - Speaker Box
 - Pedal Board
 - Screw x 10
 - Cap x 10 (and additional spare caps)
 - Cord Cramps
- Lid Holder
- AC Adaptor (DC 9V), AC Cord
- Lid
- Music Stand
- Owner's manual (this document)
 - Tempo Setting Sheet

Introduction

Assembling the F-100



Make sure that another person is on hand to help with the assembly and setup.

To move the piano, lift it carefully—all the while keeping it level. Be very careful, when you assemble and move the piano, to make sure that you do not drop it on your hands or feet.

Always carry out this procedure with the F-100 lying horizontally, with the rear panel facing down.

Check the Parts

Before you begin assembling the F-100, check that all the parts were supplied.

You will also need to have a Phillips screwdriver.

① F-100

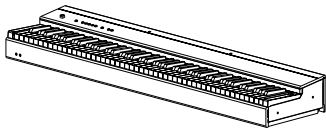

② Speaker box

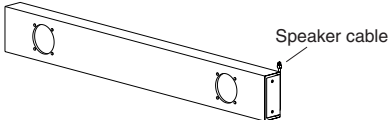

③ Side panel right and left

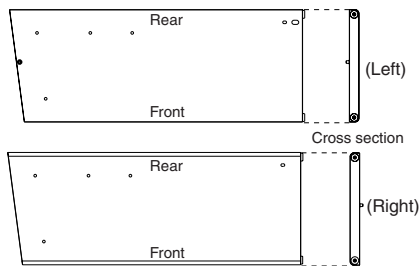

④ Pedal Board

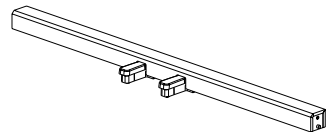

⑤ Screw x 10

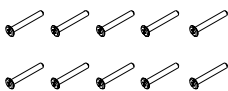

⑥ Cap x 10

(and some spare caps)



MEMO

The speaker box can also be installed so that it faces toward the rear instead of toward the front. Having the speaker box face out the rear of the instrument allows the speakers to be directed toward listeners when the back of the instrument faces the audience.

Normal direction

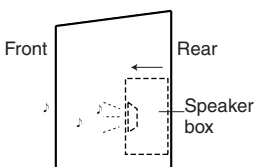

When facing to the rear

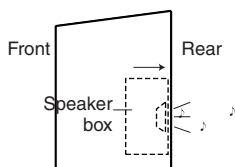

Assembly Procedure

- At first, assemble the entire unit in a temporary fashion, without really tightening the screws. Then, after checking the overall alignment of the boards (and gently shifting certain parts where necessary), go around and tightly fasten each of the screws.
- Be careful when assembling the F-100, so as to avoid scratching the side panels.

When securing the screws, lay the entire unit sideways with the rear side of the F-100 at the bottom.

1. Tighten the screws on one of the side panels to secure that side panel the F-100 and speaker box (four locations).

Install so that the speaker cable at the rear of the speaker box extends to the right side (the side where the F-100's [Power] switch is located).

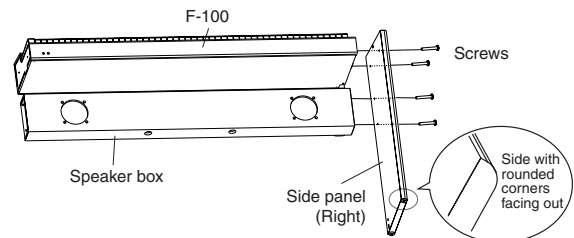

2. Align the projection of the pedal board with the hole in the side panel, and use a screw to fasten the pedal board (one location).

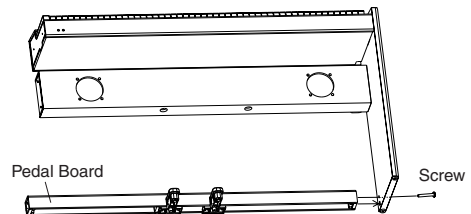

3. Align the hole in the other side panel with the projection of the pedal board, and use a screw to fasten the pedal board (one location).

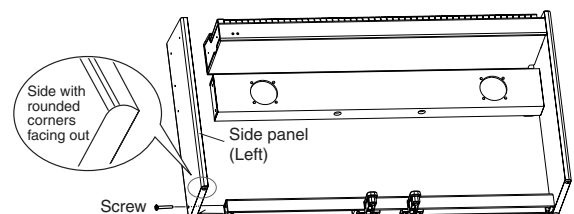

4. Tighten the screws on the side panels to secure that side panel the F-100 and speaker box (four locations).

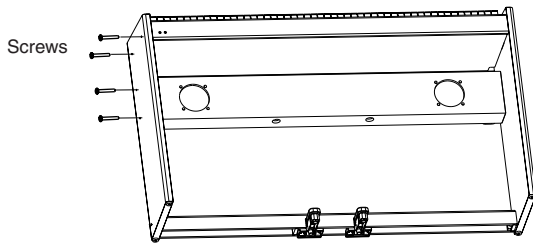

5. Stand the instrument back up.

When lifting the instrument back up, grasp near the center of the speaker box and the F-100, and gently raise the instrument.

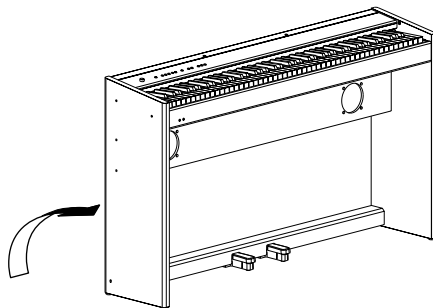

If the Stand is Uneven

If after lifting the F-100 back up you find that stand is crooked, try loosening the screws and then securing them again. When retightening, start with the top screws, then work your way down. When doing this, slightly loosen the screws before firmly tightening them.

To stabilize the pedals

Temporarily loosen the screws that fasten the pedal board.

Step on the pedal, and after verifying that the pedal is in firm contact with the floor, re-tighten the screws firmly.

6. Place the caps over the heads of the screws (five on each side).

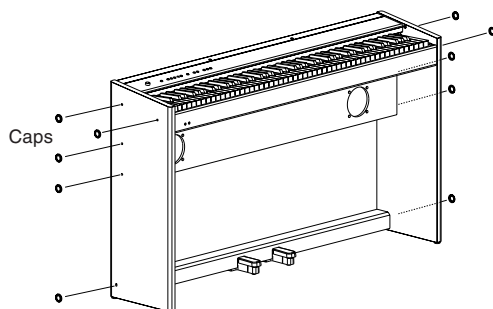

7. Connect the speaker cable extending from the rear of the speaker box to the F-100's speaker connector.

Press the speaker cable completely into the connector so that it is securely fastened.

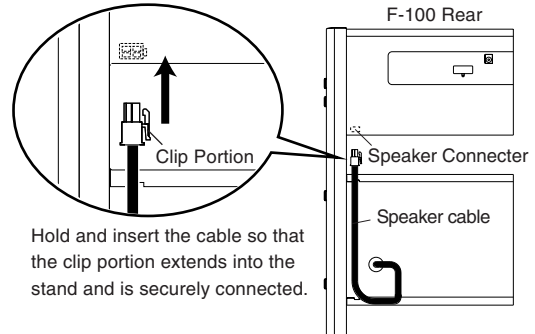

8. Connect the pedal cables to the Pedal [Damper] jack and [Soft] jack.

Connect the brown plug to the Damper jack, and the black plug to the Soft jack.

9. As necessary, affix cord cramps as shown in the diagram to fasten the pedal cable.

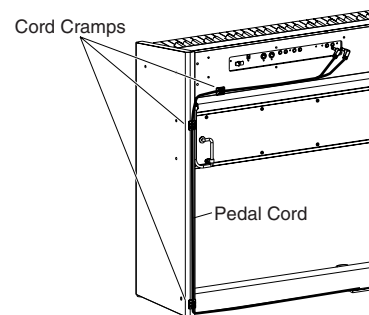

When Moving the Instrument

Disconnect the AC cord, cables, the music stand and the lid from the F-100.

Then lift the piano while keeping it level, and move it with care, so that you do not drop it on your feet, or get your hands caught.

Check the stability of the pedal, and make adjustments as necessary.

When Disassembling

Disassemble the unit by carrying out assembly Steps 1-8 in reverse order.

When Changing the Orientation of the Speaker Box

Be sure to completely disassemble the unit, change the speaker box orientation, then reassemble it.

Panel Descriptions

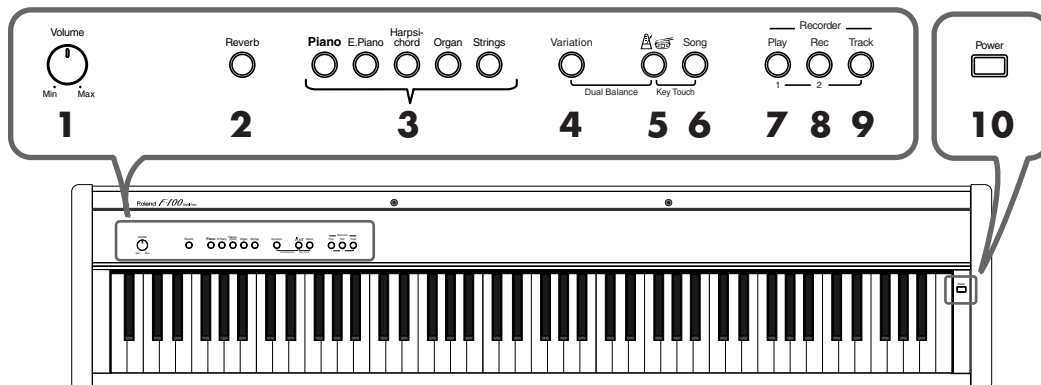

1. [Volume] Knob

Adjusts the volume (p. 12).

2. [Reverb] Button

Used to add reverberation to the sound (p. 17).

3. Tone Buttons

The following five buttons are collectively referred to as the Tone buttons. These are used to select the tone to played via the keyboard (p. 15).

- [Piano] Button
- [E.Piano] Button
- [Harpsichord] Button
- [Organ] Button
- [Strings] Button

4. [Variation] Button

This is used in combination with the Tone buttons to select the instrument sounds to be played with the keyboard (p. 15).

5. [Metronome/Rhythm] Button

Activates the built-in metronome or rhythm (p. 17, p. 20).

6. [Song] Button

This plays the internal piano songs (p. 13).

Recorder

7. [Play]/[1] Button

Starts playback of recorded performance.

When you press the [Track] button, the [Play] button will function as the Track [1] button (p. 14).

This button and the following [2] button are collectively referred to as the "Track buttons."

8. [Rec]/[2] Button

Records your performance (p. 21).

When you press the [Track] button, the [Rec] button will function as the Track [2] button (p. 14).

9. [Track] Button

Hold down this button while you switch playback or recording on/off for the [1] and [2] buttons (p. 14, p. 24).

10. [Power] Switch

This switch turns the unit on/off (p. 12).

Applying the Tempo Setting Sheet

If desired, you can affix the included tempo setting sheet to the instrument.

Use the tempo setting sheet when setting the metronome tempo.

Position and apply the tempo setting sheet as shown in the figure.

For more details, refer to "Changing the Tempo" (p. 18).

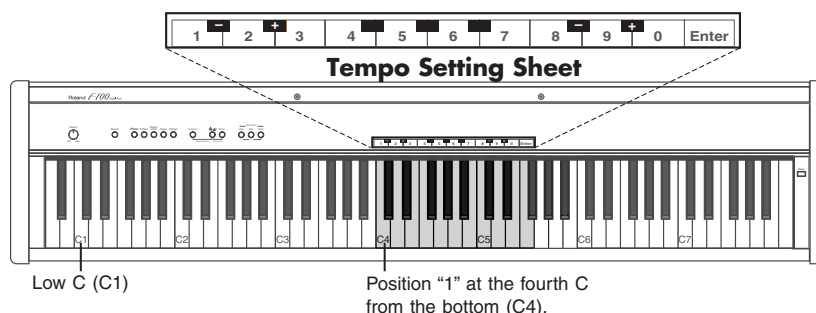

Contents

USING THE UNIT SAFELY	2
IMPORTANT NOTES	4
Introduction	5
Main Features	5
Checking the Included Items.....	5
Assembling the F-100	6
Check the Parts.....	6
Assembly Procedure.....	6
Panel Descriptions	8
Applying the Tempo Setting Sheet.....	8
Before You Play.....	10
Connecting the AC Adaptor.....	10
Installing the Music Stand	10
Connecting Pedals.....	10
Assembling the Lid	11
Installing the Lid Holders	11
Turning On the Power.....	12
Turning Off the Power	12
Adjusting the Volume	12
Connecting Headphones (Sold Separately).....	12
Listening to the Internal Songs	13
Playing/Stopping the Internal Songs.....	13
Selecting a Song for Playback.....	13
Playing Each Hand Separately.....	14
Playing the Keyboard	15
Selecting the Instrument Sound You Wish to Play	15
Layering Two Instrument Sounds (Dual Play).....	16
Adding Reverberation to Sounds (Reverb Effect).....	17
Sounding the Metronome	17
Changing the Tempo	18
Changing the Beat.....	19
Adjusting the Volume	19
Playing Rhythm.....	20
Recording Your Performance	21
Recording a Performance.....	21
Recording Along with the Rhythm	22
Recording Along with a Song	23
Selecting and Recording the Track for Each Hand Separately..	24
Erasing Recorded Performances	25
Erasing a performance from the specified track.....	25
Erasing a song.....	25
Some Handy Functions	26
Changing the Keyboard's Touch	26
Disabling Buttons (Panel Lock).....	26
Transposing without Changing Your Keyboard Fingering (Key Transpose).....	27
Adjusting the Pitch of the Sound (Master Tuning)	27
Lowering/ raising the Reference Pitch	27
Setting the Reference Pitch to 440.0 Hz.....	28
Setting the Reference Pitch to 442.0 Hz.....	28
Changing the Volume Balance in Dual Play	28
Changing the Depth of the Reverb	28
Checking the depth of the Reverb Effect	28
Connecting to Audio Equipment	29
About the Jacks.....	29
Making the Connections	29
Connecting to MIDI Devices	30
About the MIDI Connectors	30
Making the Connections	30
Cautions when Connecting an External MIDI Device.....	31
Disconnecting the F-100's keyboard and internal sound generator (Local On/Off).....	31
Switching Local On/Off.....	31
Receiving on all MIDI channels (Omni On/Off).....	31
Switching Omni On/Off	31
Set the MIDI Channel	32
Transmitting a performance you recorded	32
Troubleshooting	33
Internal Song List.....	34
MIDI Implementation	36
Main Specifications.....	37
Functions Assigned to the Keyboard	38
Functions for Metronome/Rhythm.....	38
Other Functions	38
Index.....	39
Information	42

Before You Play

Connecting the AC Adaptor

NOTE

To prevent malfunction and/or damage to speakers or other devices, always turn down the volume, and turn off the power on all devices before making any connections.

1. Connect the supplied AC adaptor and AC cord.

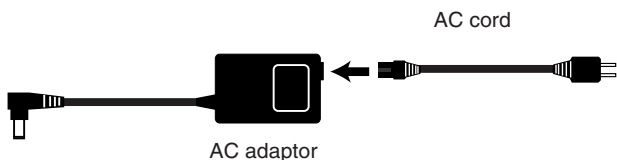

2. Connect the AC adaptor to the DC In connector on the rear panel.
3. As shown in the diagram, loop the AC adaptor cord around the cord hook to fasten it in place.

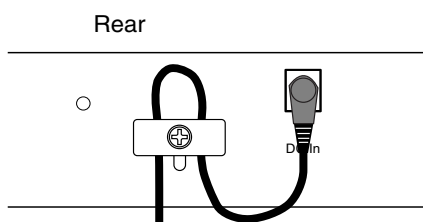

4. Plug the AC cord into a power outlet.

As necessary, cramp the AC adaptor cord with the cord cramps (p. 7).

NOTE

To prevent the inadvertent disruption of power to your unit (should the plug be pulled out accidentally), to avoid applying undue stress to the DC In connector, anchor the power cord using the cord hook, as shown in the diagram. Even if the cord is fastened, strong tension applied to the cord may cause it to be damaged or broken. Be careful not to pull the cord accidentally, or to apply strong pressure to it.

Installing the Music Stand

1. Assemble the music stand as shown in the diagram.

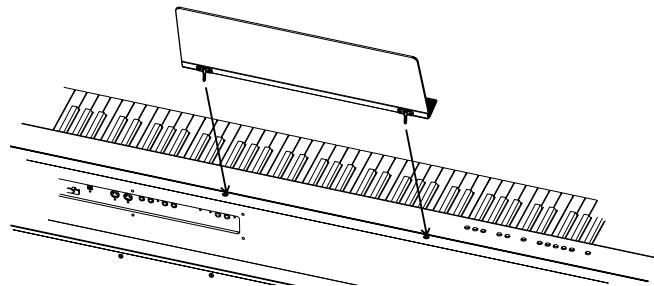

NOTE

When moving the piano, be sure to remove the music stand as a safety precaution.

NOTE

Do not apply excessive force to the installed music stand.

Connecting Pedals

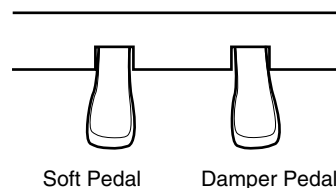

Soft Pedal

This pedal is used to make the sound softer. Playing with the soft pedal depressed produces a sound that is not as strong as when otherwise played with the equivalent strength. This is the same function as the left pedal of an acoustic piano. Some tones are affected less than others.

Damper Pedal

Use this pedal to sustain the sound. While the pedal is depressed, long lingering reverberations continue to be added to the sound after you release from the keys. This is the same function as the right pedal of an acoustic piano.

NOTE

Unplugging a pedal cord from the unit while the power is on may cause the pedal's effect to be applied without stopping. The power of the F-100 must be turned off before inserting or removing a pedal cord.

Assembling the Lid

NOTE

You must always use both hands to open or close the lid. When opening and closing the lid, be very careful not to catch your finger in the lid.

1. Attach the included lid as shown in the diagram.

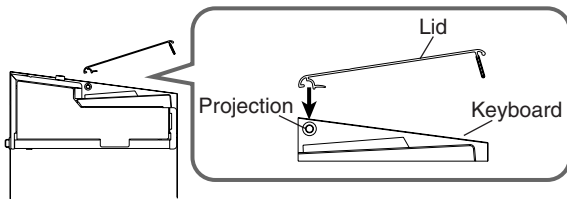

2. When opening the lid, grasp the lid with your hands and gently lift it upwards.

3. When closing the lid, grasp the lid with your hands and gently lower it down.

NOTE

Make sure an adult is on hand to provide assistance when young children are playing the F-100.

NOTE

When you move the piano, be sure to remove the lid to prevent accidents. Be careful not to drop the removed lid.

■ Installing the Lid Holders

Attaching the supplied lid holders provides you with a place to rest the lid whenever it's been removed.

Check the Parts

Lid Holders (left and right)

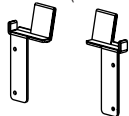

Attachment screws (4)

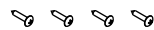

Installation Procedure

1. Remove the four screws from both sides of the rear panel of the F-100.

* Be careful not to lose the screws you've removed. You will need to put them back in place at the rear of the F-100 if you decide that you don't want to use the lid holders.

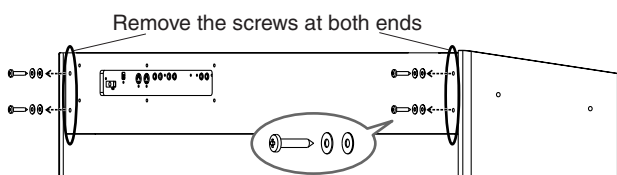

2. Attach the lid holders to the rear panel of the F-100 using the supplied attachment screws (four locations).

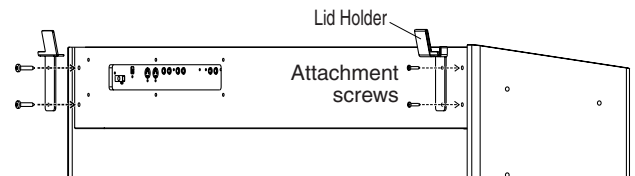

Placing the Lid

Rest the lid on the lid holders gently, as shown.

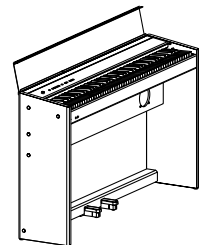
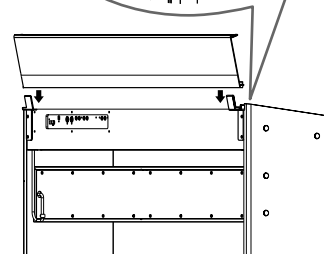
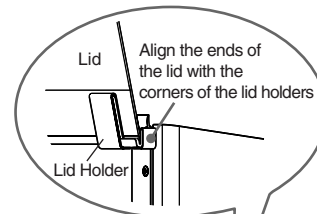

NOTE

Never lean against, nor apply excessive force to the lid while it is resting on the lid holders.

Before You Play

Turning On the Power

NOTE

Once the connections have been completed, turn on power to your various devices in the order specified. By turning on devices in the wrong order, you risk causing malfunction and/or damage to speakers and other devices.

1. Turn the [Volume] knob completely to the left to lower the volume to the minimum level.

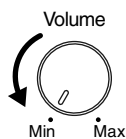

2. Push the [Power] switch to turn on the F-100.

After a few seconds, the unit becomes operable and playing the keyboard produces sound.

Adjust the volume to obtain the proper volume level.

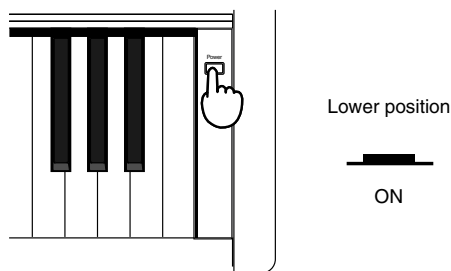

NOTE

This unit is equipped with a protection circuit. A brief interval (a few seconds) after power up is required before the unit will operate normally.

Turning Off the Power

1. Turn the [Volume] knob completely to the left to lower the volume to the minimum level.

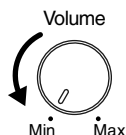

2. Push the [Power] switch to turn off the F-100.

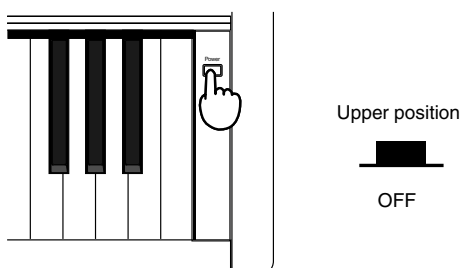

Adjusting the Volume

1. Use the [Volume] knob to adjust the overall volume level.

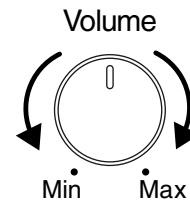

NOTE

Raising the volume excessively may cause the sound to distort. Enjoy the piano at an appropriate volume level.

Connecting Headphones (Sold Separately)

The F-100 features two headphone jacks. This allows two people to listen through headphones simultaneously, making it very useful for lessons and when performing piano pieces for four hands. Additionally, this allows you to play without having to worry about bothering others around you, even at night.

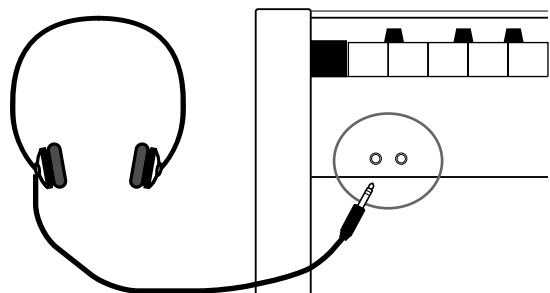

1. Turn the [Volume] knob to lower the volume to the minimum level.
2. Connect the headphones to either of the headphone jacks.
3. Use the [Volume] knob to adjust the overall volume level.

The sound from the built-in speakers stops. Sound will be heard only through the headphones.



Use Stereo headphones (stereo miniature phone type).

Listening to the Internal Songs

The F-100 comes with sixty internal songs.

Playing/Stopping the Internal Songs

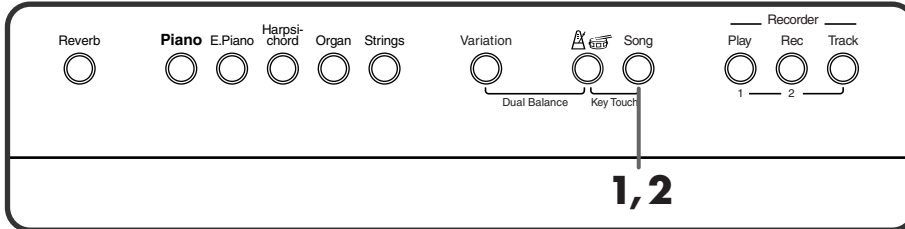

1. Press the [Song] button, getting its indicator to light.

The internal songs will play back in succession. When the last song has been played, playback will return to the first song and begin again.

2. To stop the internal song playback, press the [Song] button to make the indicator go out.

The internal song playback will stop.

■ Selecting a Song for Playback

Here's how you can select and play a desired internal song.

1. While holding down the [Song] button, press the key that corresponds to the internal song you wish to hear.

The internal songs are assigned to the keys in sequential order, starting with the leftmost key.

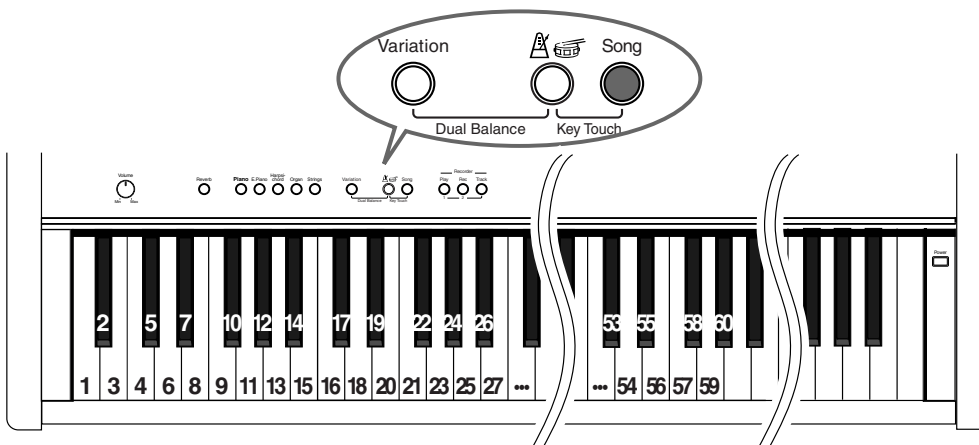

The indicator of the [Song] button will light. When the last song has been played, playback will return to the first song and resume.

2. To stop the internal song playback, press the [Song] button to make the indicator go out.

The internal song playback will stop.

MEMO

For more on song list, please refer to "Internal Song List" (p. 34).

MEMO

When you play back an internal song, the reverb effect (p. 17) will automatically be turned on (the button's indicator lights).

MEMO

When you press the [Song] button, the songs will play back in succession, starting with the previously selected song.

MEMO

You can adjust the tempo of the song that is playing. Please refer to "Changing the Tempo" (p. 18).

NOTE

It is not possible to sound the rhythm (p. 20) while an internal song is playing.

Listening to the Internal Songs

■ Playing Each Hand Separately

The internal songs allow you to select the performance part that will be played back.

The left-hand performance of the internal songs is assigned to the [1] button, while the right-hand performance is assigned to the [2] button. The place where each part of the performance is held is called a “track,” and the [1] and [2] buttons are called “track buttons.”

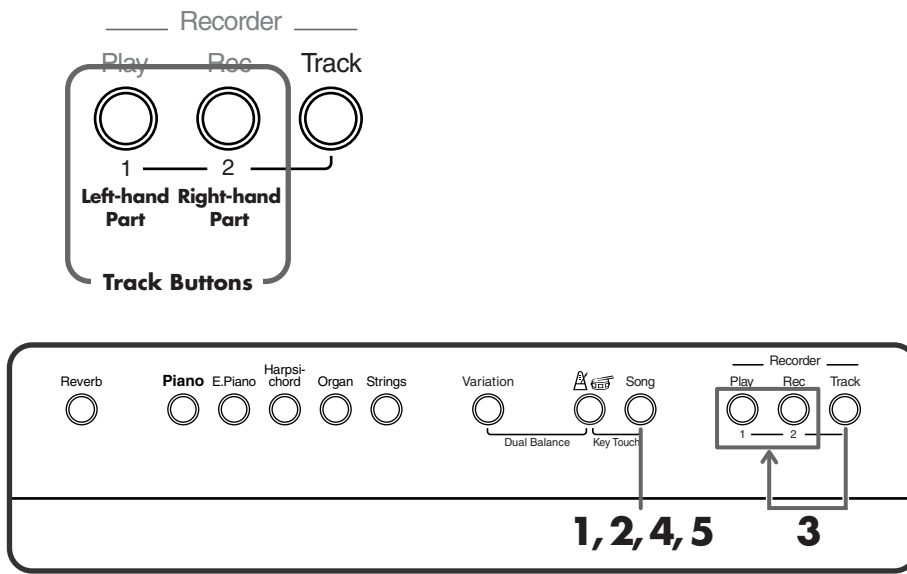

- 1. While holding down the [Song] button, press the key that corresponds to the internal song you wish to hear.**

The song will begin playing back.

- 2. Press the [Song] button to stop the internal song playback.**

- 3. While holding down the [Track] button, press the [1] or [2] button for any track not to be played back.**

- 4. Press the [Song] button, getting its indicator to light.**

The song selected in step 1 will begin playing back.

The part you selected in step 3 will not sound.

Once again hold down the [Track] button and press the button you selected in step 3, illuminating its indicator. The sound will be heard again.

In this way, you can mute the sound, or have it play by holding down the [Track] button and pressing the [1] or [2] button.

- 5. Press the [Song] button.**

Choices you've made as to whether a particular performance part plays or not get cancelled as soon as another song plays.



To select a performance part of an internal song, play back the song, then make your selection.

Playing the Keyboard

Selecting the Instrument Sound You Wish to Play

The F-100 allows you to play using twenty different tones including piano. You can select the tones using the five Tone buttons; four tones are assigned to each button. You can switch the tones assigned to each button by pressing the [Variation] button.



Since the organ tones reproduce the sound of a traditional organ, in certain registers you may be able to perceive that they exhibit a certain amount of harmonic foldback.

Tone button	Piano	E. Piano	Harpichord	Organ	Strings
Tone number 1 [Variation] OFF (dark)	Grand Piano	Stage Rhodes	Harpichord	Pipe Organ	Strings
Tone number 2 [Variation] lit in red	Bright Piano	Electric Piano	Organ Flute	Rotary Organ	Choir
Tone number 3 [Variation] lit in green	Grand Piano/ Acoustic Bass*	Vibraphone	Clavi	Pipe Organ/ Strings*	Strings+Brass*
Tone number 4 [Variation] lit in orange	Grand Piano/ Strings*	Stage Rhodes/ Electric Bass*	Harpichord/ Strings*	Jazz Organ/ Rotary Organ*	Flute/ Strings*

* Strings+Brass: lets you play a combination of strings and brass tones

* A/B: dividing the keyboard into right-hand and left-hand areas, then playing different tones A, the right-hand tone; and B, the left-hand tone

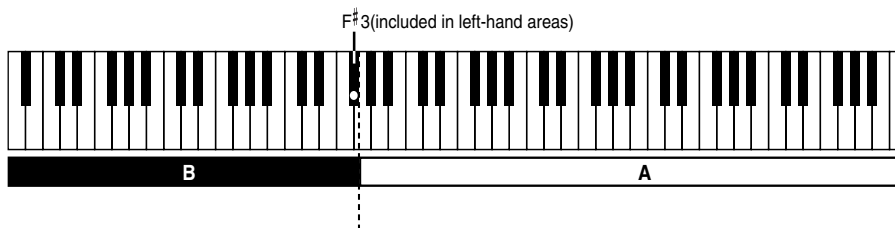

When the F-100 is turned on, the tone is reset to Grand Piano.

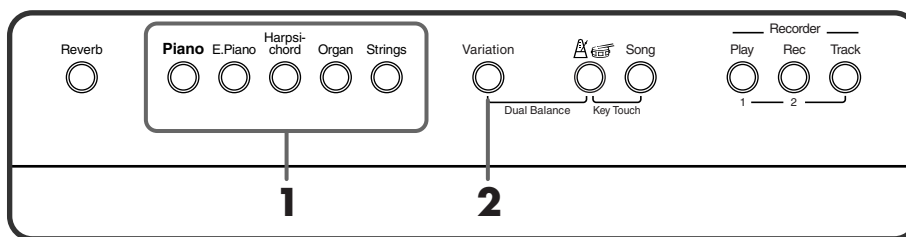

1. Press any Tone button.

The indicator on the selected button lights up.

2. Press the [Variation] button to select the Tone.

Each time you press the [Variation] button, the button's indicator will change color, and the four sounds will be selected successively.

The Tone you've selected is heard when you finger the keyboard.

The next time you choose this Tone button, the tone you've selected here is played.



When you select A/B tones, the damper pedal will be applied only to the right-hand area of the keyboard.



A/B tones have settings optimized for playing with the keyboard divided into right-hand and left-hand zones. With some tones, the octave (pitch) settings may differ on opposing sides of the border between the keyboard zones.



Dual play (p. 16) can be used when tone numbers 1 or 2 are selected.

If you use Dual play with a Tone button for which tone number 3 or 4 is selected, tone number 1 will be selected for that Tone button.

Layering Two Instrument Sounds (Dual Play)

You can hold down one Tone button and press another Tone button to layer two sounds for playing together.

This function is called “Dual Play.”

Example: Combining Piano and Strings

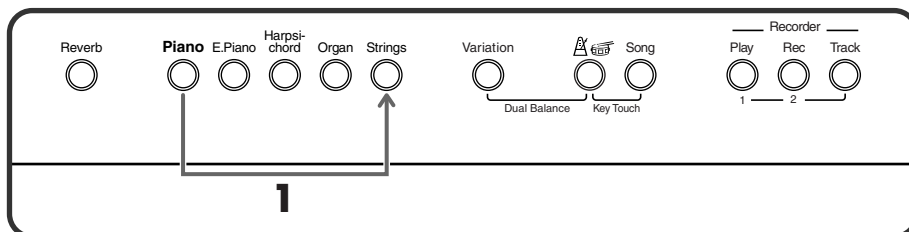

1. While pressing the [Piano] button, also press the [Strings] button.

The indicators for both buttons light.

When you then play the keyboard, the layered sounds of the piano and strings will play.

The [Variation] button indicator now indicates the tone for the right button of the two selected Tone buttons.

Switching the [Variation] button on and off switches the right Tone button tone.

2. To cancel Dual Play, press either Tone button.

When you play the keyboard, only the tone of the button you pressed will be heard.



You can adjust the volume balance between the two selected tones in Dual Play. For details, refer to “Changing the Volume Balance in Dual Play” (p. 28).

When the power is turned on, the sound of the left Tone button is set to be louder.



Dual play can be used when tone numbers 1 or 2 are selected.

If you use Dual play with a Tone button for which tone number 3 or 4 is selected, tone number 1 will be selected for that Tone button.

Adding Reverberation to Sounds (Reverb Effect)

You can apply a reverb effect to the notes you play on the keyboard. Applying reverb adds pleasing reverberation to what you play, so it sounds almost as if you were playing in a concert hall.

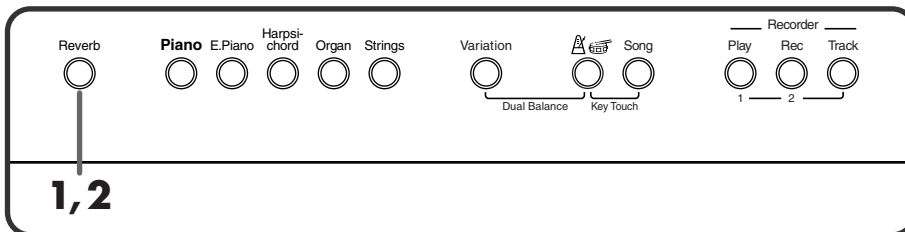

1. Press the [Reverb] button, and confirm that its indicator has lighted.

The reverb effect is applied to the sound.

2. Pressing the [Reverb] button once more turns off the button's indicator and cancels the reverb effect.

Sounding the Metronome

Here's how you can make use of the metronome.

While a song plays back, the metronome will sound at the tempo and beat (time signature) of that song.

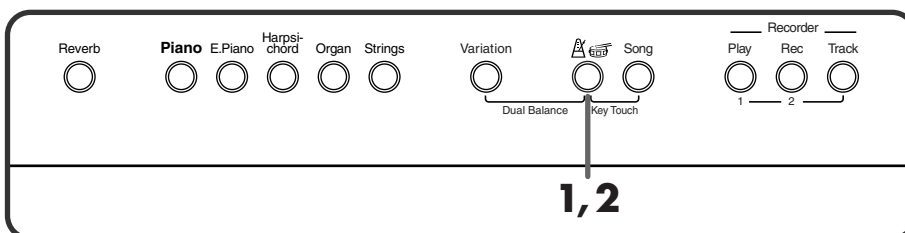

1. Pressing the [Metronome/Rhythm] button starts the metronome's sound.

The [Metronome/Rhythm] button's indicator flashes in time with the tempo selected at that time.

2. To stop the metronome, press the [Metronome/Rhythm] button, extinguishing its indicator.



When you play back an internal song, the reverb effect will automatically be turned on (the button's indicator lights).



You can select the depth of reverb effect. For details, refer to "Changing the Depth of the Reverb" (p. 28).



If Rhythm is selected, the metronome will not sound even if you press the button. Please re-select the beat (time signature) of the metronome (p. 19).

Playing the Keyboard

■ Changing the Tempo

Adjusting the tempo of the metronome, rhythm (p. 20) and the song in playing back.

To change the tempo, specify the numerical values by pressing the keys to which the numbers 0–9 or +/- are assigned.

You can set a tempo in the range of ♩=20–250.

Example: Specifying a Tempo of 96

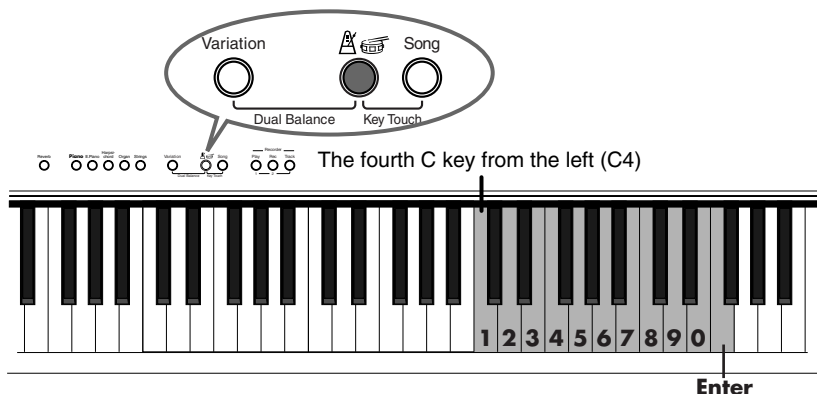



1. Hold down the [ (Metronome/Rhythm)] button and press the “9” and “6” keys in that order, then press the “Enter” key.

The metronome tempo switches to 96.

You can use this method of holding down the [ (Metronome/Rhythm)] button and pressing the keys to which the numerical values are assigned (C4–E5) and “Enter” key (F5) to use numerals to specify the tempo.

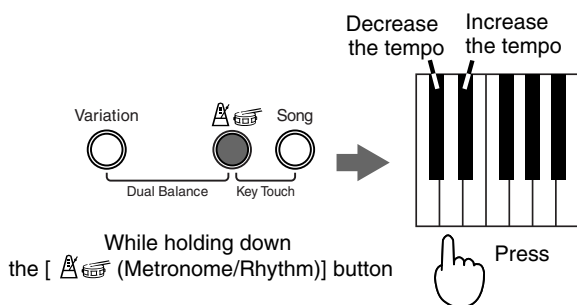
Increasing and Decreasing the Tempo One Count at a Time



1. While holding down the [ (Metronome/Rhythm)] button, press C# to decrease the tempo by one count, or press D# to increase the tempo by one count.

While holding down the [ (Metronome/Rhythm)] button, also hold down C# or D# to change the tempo continuously.

You can change the tempo by pressing any C# or D# key.

If you hold down the [ (Metronome/Rhythm)] button and simultaneously press the C# and D# keys, you will return to a tempo of 108, or the original tempo of the selected song.

MEMO

Using the “tempo setting sheet” included with the F-100 makes it easier to grasp the values assigned to each key. For details, refer to “Applying the Tempo Setting Sheet” (p. 8).

MEMO

The tempo can be set to any value from 20 through 250. If a value less than 20 is specified, the tempo is set to 20. If a value greater than 250 is specified, the tempo is set to 250.

■ Changing the Beat

To change the beat, specify the beat by pressing the key (A0–E1) to which the beat is assigned.

You can select from the following five types: 0 (only upbeat sounds), 2 (2-beat), 3 (3-beat), 4 (4-beat), 6 (6-beat).

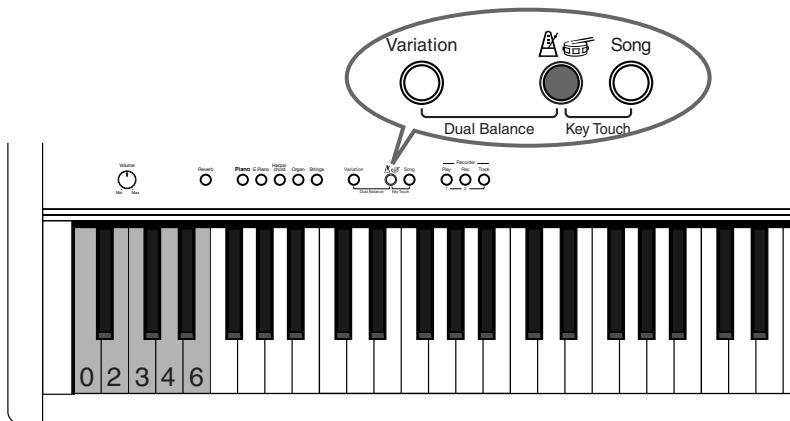

MEMO

It is not possible to change the beat during song playback or recording.

1. Hold down the [(Metronome/Rhythm)] button and press the key to which the beat is assigned.

■ Adjusting the Volume

You can adjust the volume of the metronome and rhythm (p. 20) to any of five possible levels.

The setting is at “3” when the power is turned on.

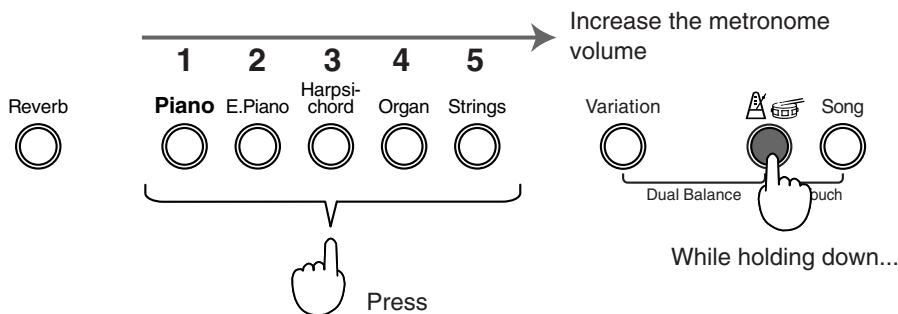

1. Hold down the [(Metronome/Rhythm)] button and press one of the Tone buttons.

The Tone button indicator will blink to indicate the current volume, when press and hold the [(Metronome/Rhythm)] button.

Playing the Keyboard

Playing Rhythm

The F-100 contains 16 different rhythms.

By playing the rhythm instead of the metronome, you can enjoy performing as if you were playing with a session-like feel.

To change the rhythm, specify the rhythm by pressing the key (F1–G3) to which the rhythm is assigned.

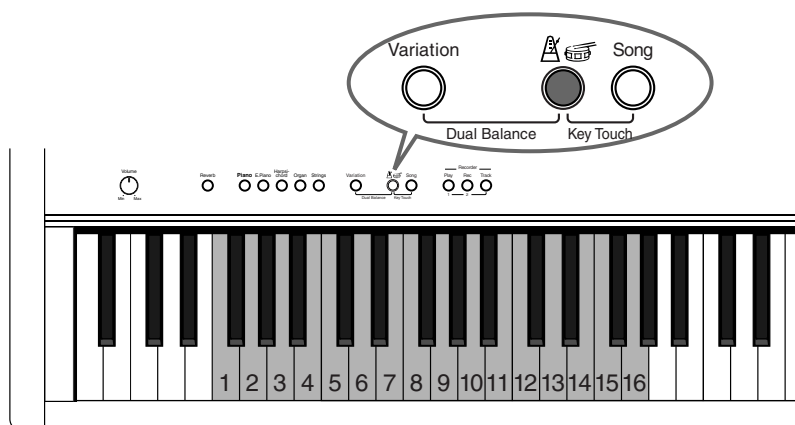

It is not possible to sound the metronome and rhythm simultaneously.



It is not possible to sound the rhythm while an internal song is playing back.

If you press the

[ (Metronome/Rhythm)] button while an internal song is playing back, the metronome will sound.

1. Hold down the [ (Metronome/Rhythm)] button, and press the key that corresponds to the rhythm.

No.	Key	Rhythm	Beat	No.	Key	Rhythm	Beat
1	F1	16 Beat	4/4	9	G2	Waltz 2	3/4
2	G1	8 Beat	4/4	10	A2	Jazz Waltz	3/4
3	A1	Rock	4/4	11	B2	March	2/4
4	B1	4/4 Shuffle	4/4	12	C3	Tango	4/4
5	C2	4/4 Triplet	4/4	13	D3	Bossa Nova	4/4
6	D2	Swing 1	4/4	14	E3	Mambo	4/4
7	E2	Swing 2	4/4	15	F3	Samba	2/4
8	F2	Waltz 1	3/4	16	G3	House	4/4

2. To stop the rhythm, press the [ (Metronome/Rhythm)] button, extinguishing its indicator.

You can change the tempo of the rhythm in the same way as for the metronome (p. 18), and adjust its volume (p. 19).

Recording Your Performance

You can easily record your performances.

A recorded performance can be played back to hear your own playing, or to add additional parts.

Notes Regarding Recording

- Only one song can be recorded. If you begin recording when a previously recorded performance exists, the previous performance will be erased.

- Recorded performances are erased when the power is turned off.

If you want to keep your performance, you can either record it on an external audio device (p. 29), or use an external MIDI device to save the performance data on a floppy disk (p. 32).

Recording a Performance

Record only the keyboard performance.

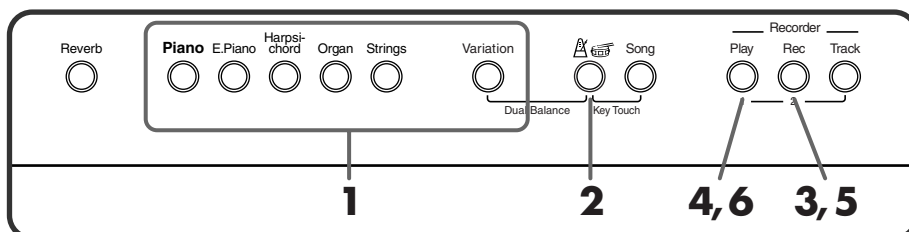

- 1. Select the tone that you want to play (p. 15).**

- 2. If necessary, turn on the metronome.**

Sound the metronome while you set the tempo and beat of the song (p. 18).

- 3. Press the [Rec] button.**

The [Rec] button's indicator will light, the [Play] button's indicator will blink, and you will be in recording-standby mode.

To cancel recording, press the [Rec] button once more.

- 4. Recording will start when you either press the [Play] button or play the keyboard.**

The F-100 counts down two measures, then recording starts.

Note that recording will also begin as soon as you play anything on the keyboard, even if you do not press the [Play] button. There is no count sound played when you start in this manner.

- 5. To stop recording, press the [Play] or [Rec] button.**

The indicators for the [Play] and [Rec] buttons will go dark.

Play back the recorded performance

- 6. Press the [Play] button.**

Once again press the [Play] button, and playback will stop.

NOTE

If you layer a newly recorded performance without erasing the recorded song, the song tempo, beat and the selected rhythm will be stored with the settings that were recorded first. Please erase the previously recorded song before you record a new performance (p. 25).

Recording Along with the Rhythm

You can record a performance that uses the Rhythm function.

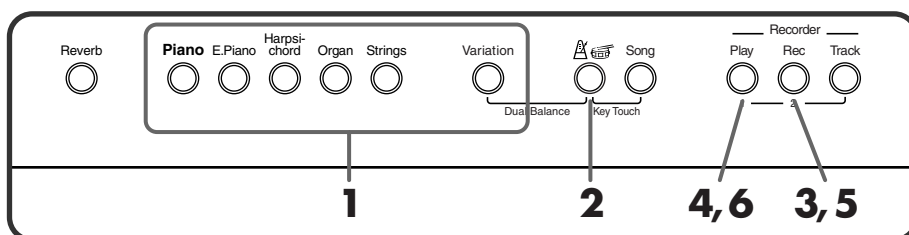

1. Select the tone that you want to play (p. 15).

2. Select the rhythm (p. 20).

Set the tempo so that you can play comfortably.

3. Press the [Rec] button.

The [Rec] button's indicator will light, the [Play] button's indicator will blink, and you will be in recording-standby mode.

To cancel recording, press the [Rec] button once more.

4. Recording will start when you either press the [Play] button or play the keyboard.

Recording begins after two measures of count sound.

Note that recording will also begin as soon as you play anything on the keyboard, even if you do not press the [Play] button. There is no count sound played when you start in this manner.

Begin recording your performance along with the rhythm.

5. To stop recording, press the [Play] or [Rec] button.

The indicators for the [Play] and [Rec] buttons will go dark.

Play back the recorded performance

6. Press the [Play] button.

Once again press the [Play] button, and playback will stop.

If the rhythm does not sound when you play back the recorded performance

Is the [ (Metronome/Rhythm)] button on (button's indicator blinking)?

If you want to play back the performance using rhythm, turn on the

[ (Metronome/Rhythm)] button.

NOTE

If you layer a newly recorded performance without erasing the recorded song, the song tempo, beat and the selected rhythm will be stored with the settings that were recorded first. Please erase the previously recorded song before you record a new performance (p. 25).

NOTE

A performance you've recorded using rhythm cannot be played back with the metronome.

Recording Along with a Song

You can record a performance that you play along with an internal song.

The recorder of the F-100 has two recording tracks, allowing you to record the right and left hands separately. Use the [1] button or [2] button with holding down the [Track] button to specify the recording track.

1. Hold down the [Song] button and press the corresponding key to the song for recording.

The song will begin playing back.

2. Press the [Song] button again to stop the song playback.

3. Holding down the [Song] button, press the [Rec] button.

The indicators for the [Song] and [Rec] buttons will light, and the [Play] button's indicator will blink.

If necessary, turn on the metronome and adjust the tempo (p. 17).

To cancel recording, press the [Rec] button once more.

4. Holding down the [Track] button, press the [1] or [2] button to select the recording track.

When you want to record the left-hand performance, press the [1] button; to record that of the right hand, press the [2] button.

5. Recording will start when you either press the [Play] button or play the keyboard.

Recording begins after two measures of count sound.

Note that recording will also begin as soon as you play anything on the keyboard, even if you do not press the [Play] button. There is no count sound played when you start in this manner.

6. To stop recording, press the [Play] or [Rec] button.

The indicators for the [Play] and [Rec] buttons will go dark.

Play back the recorded performance

7. Press the [Play] button.

Once again press the [Play] button, and playback will stop.

MEMO

For more on song list, please refer to "Internal Song List" (p. 34).

NOTE



It is not possible to sound the rhythm (p. 20) while an internal song is playing.

MEMO

To select a performance part of an internal song, play back the song, then make your selection.

MEMO

Status of the indicators for buttons [1] [2] when the [Track] button is pressed

Dark 	Not recording No data recorded
Lit 	Not recording Data recorded
Blink 	Recording

MEMO

When you record a song that begins on a weak beat (an upbeat; i.e., a beat other than the first beat), recording will begin after the count has sounded for the first measure.

Selecting and Recording the Track for Each Hand Separately

If you want to re-do the recording, you can re-record just a specific track.

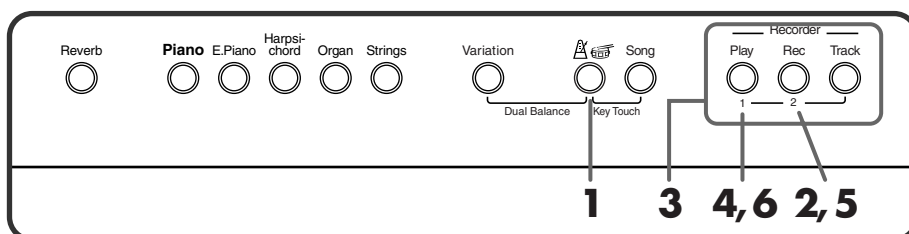

NOTE

If you layer a newly recorded performance without erasing the recorded song, the song tempo, beat and the selected rhythm will be stored with the settings that were recorded first.

- 1.** As necessary, turn on the metronome or rhythm (p. 17).
- 2.** Press the [Rec] button.
The [Rec] button's indicator will light.
When you press the [Track] button, the track button indicator of the track you recorded earlier will blink.
- 3.** Holding down the [Track] button, press the [1] or [2] button to select the track that you want to record.
- 4.** Recording will start when you either press the [Play] button or play the keyboard.

Recording begins after two measures of count sound.

Note that recording will also begin as soon as you play anything on the keyboard, even if you do not press the [Play] button. There is no count sound played when you start in this manner.

- 5.** To stop recording, press the [Play] or [Rec] button.

The indicators for the [Play] and [Rec] buttons will go dark.

Your performance has been recorded to the specified track button.

If you want to record on the other track, return to step 2 to record your performance again. You can record while you listen to the previously recorded performance.

Play back the recorded performance

- 6.** Press the [Play] button.

You will hear the recorded performance.

Press the [Play] button once again, and playback will stop.

MEMO

Status of the indicators for buttons [1] [2] when the [Track] button is pressed

Dark 	Not recording No data recorded
Lit 	Not recording Data recorded
Blink 	Recording

Erasing Recorded Performances

You can erase a recorded performance.

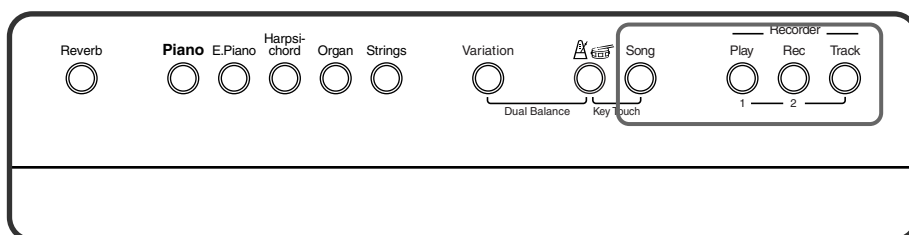

■ Erasing a performance from the specified track

You can select a recorded track and erase it.

1. While holding down the [Track] button, press the [1] or [2] button; continue holding them down for a while.

After the buttons have been held down for several seconds, the [Song] button and the [1] and [2] buttons will blink briefly, and the performance of the selected track will be erased.

■ Erasing a song

You can erase a song you've recorded.

1. While holding down the [Track] button, press the [Song] button; continue holding them down for a while.

After the buttons have been held down for several seconds, the [Song] button and the [1] and [2] buttons will blink briefly, and the performance you recorded will be erased.

Some Handy Functions

Changing the Keyboard's Touch

You can change the touch sensitivity, or response of the keys. The setting is at "Medium" when the F-100 is powered up.

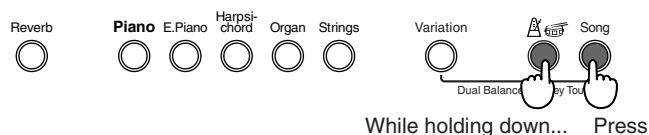

1. Hold down the [(Metronome/Rhythm)] button and press the [Song] button.

The [(Metronome/Rhythm)] button, [Song] button and the Tone button for the currently selected value flash.

2. Press any Tone button.

The pressed button's indicator blinks.

Tone button	Touch Sensitivity	Descriptions
Piano	Fixed	Notes are sounded at an unchanging volume level, regardless of how lightly or forcefully you finger the keyboard.
E.Piano	Light	Fortissimo (ff) can be obtained with weaker touch than usual, so, you will feel that the keyboard is lighter. This setting makes it easy to play, even for children.
Harpsi-chord	Medium	This is the most natural touch for the keyboard. This is the closest to the touch of an acoustic piano.
Organ	Heavy	Fortissimo (ff) can be obtained only with forceful playing, so you will feel that the keyboard is heavier. Dynamic fingering adds even more feeling to what you play.

* The [Strings] button cannot be used in this operation.

3. Press the [(Metronome/Rhythm)] button or the [Song] button.

The button's indicator returns to its previous state.

Disabling Buttons (Panel Lock)

Making the setting for the panel lock enables a state where only piano play is possible, and all buttons are disabled. As the settings are not changed, this is convenient for piano performances.

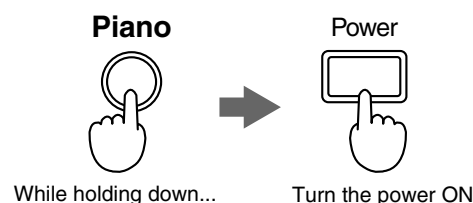

1. Before you switch on the power, turn the volume down all the way by rotating the [Volume] knob.
2. While holding down the [Piano] button, press the [Power] switch to turn on the power.
3. Adjust the volume.

Fingering the keyboard now produces a grand piano sound. It will be not possible to switch to another sound.

To defeat the Panel Lock function, turn the volume down to the minimum, and turn on the power once again.

Transposing without Changing Your Keyboard Fingering (Key Transpose)

You can transpose the key of a performance without having to shift the position of your fingers on the keyboard.

This feature is called “Key Transpose.”

In situations such as when providing accompaniment to a song, using the Key Transpose function to match the singer’s vocal register lets you easily transpose the sounds without changing the score.

These settings remains in effect until you turn off the power.

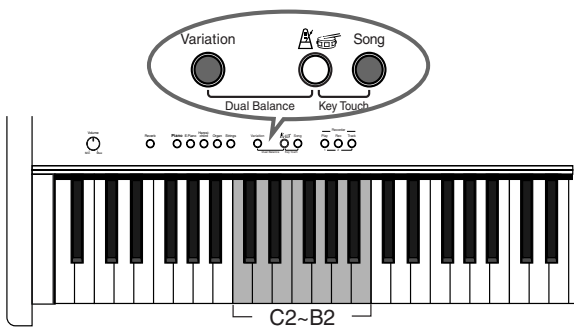

1. While holding down the [Variation] button and [Song] button, press the tonic (root) of the key to which you want to transpose.

Use the C2-B2 notes to select the tonic.

2. To return to the normal pitch, while holding down the [Variation] button and [Song] button, press the C2 key.

<Ex.>

For example if you want the E pitch to sound when you play the C key, you would hold down the [Variation] button and [Song] button and press the E2 key.

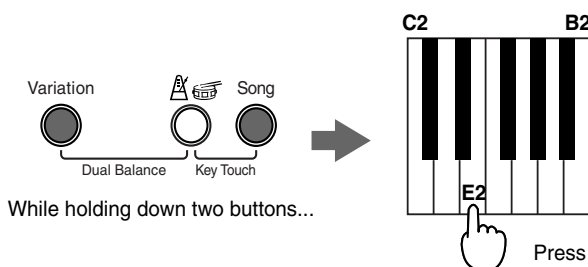

NOTE

The transposition setting is effective only on sounds performed on the F-100’s keyboard. This setting is not effective on tones from external MIDI messages played on the F-100.

Adjusting the Pitch of the Sound (Master Tuning)

In situations such as when playing ensemble with other instruments, you can tune the F-100’s reference pitch to the pitch of another instrument. The reference pitch generally refers to the pitch of the note that’s played when you finger the middle A key.

For a cleaner ensemble sound while performing with one or more other instruments, ensure that each instrument’s reference pitch is in tune with that of the other instruments.

This tuning of all the instruments to a reference pitch is called “master tuning.” You can set the reference pitch anywhere in a range of 415.3 Hz to 466.2 Hz.

When the instrument is turned on, the reference pitch is set to “440.0 Hz.”

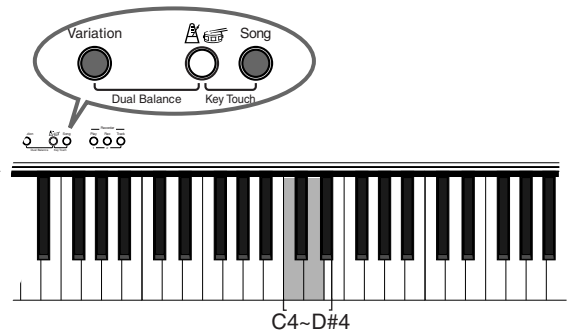

■ Lowering/ raising the Reference Pitch

1. While holding down the [Variation] button and [Song] button, press the “C4” note to lower the reference pitch, or the “D4” note to raise it.

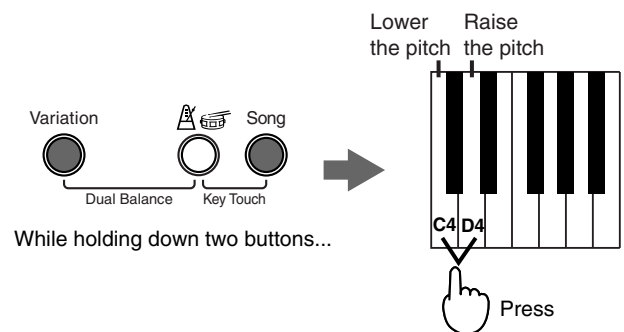

Each time you press the “C4” key, the pitch will fall by 0.1 Hz. If you continue holding the key, the pitch will continue falling.

Each time you press the “D4” key, the pitch will rise by 0.1 Hz. If you continue holding the key, the pitch will continue rising.

Some Handy Functions

■ Setting the Reference Pitch to 440.0 Hz

1. While holding down the [Variation] button and [Song] button, press the “C # 4” key on the keyboard.

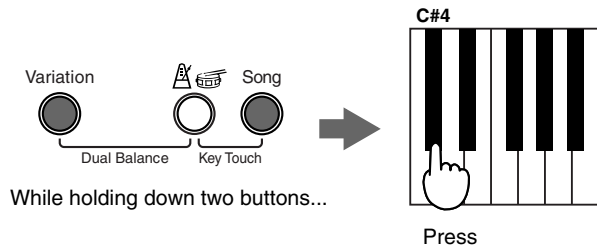

The reference pitch will be set to 440.0 Hz. This is the most commonly used setting. The A4 (Middle A) key will sound at 440.0 Hz.

■ Setting the Reference Pitch to 442.0 Hz

1. While holding down the [Variation] button and [Song] button, press the “D # 4” key on the keyboard.

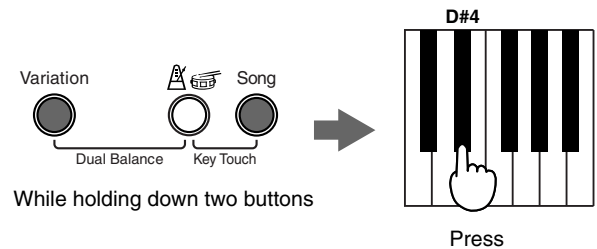

The reference pitch will be set to 442.0 Hz. This setting is often used for concert pianos. The A4 (Middle A) key will sound at 442.0 Hz.

Changing the Volume Balance in Dual Play

You can change the volume balance between the two layered sounds in Dual Play (p. 16).

When the keyboard is turned on, the volume balance is set to that the tone assigned to the left Tone button sounds louder of the two selected tones.

This setting remains in effect until the keyboard’s power is turned off.

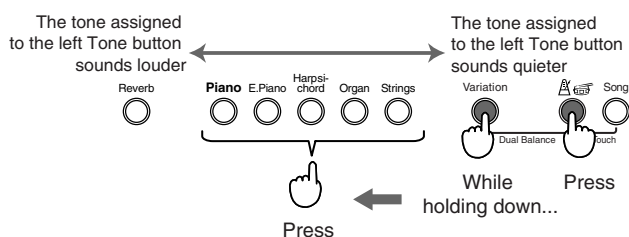

1. While holding down the [Variation] button, press the [Metronome/Rhythm] button.

The [Variation] button, [Metronome/Rhythm] button and the Tone button for the currently selected value flash.

2. Press any Tone button.

The pressed button’s indicator blinks.

Tone button	Description
Piano	Of the two selected tones, the tone assigned to the left Tone button sounds louder.
E. Piano	Of the two selected tones, the tone assigned to the left Tone button sounds somewhat louder.
Harpsi-chord	The two selected tones are played at the same volume.
Organ	Of the two selected tones, the tone assigned to the left Tone button sounds somewhat quieter.
Strings	Of the two selected tones, the tone assigned to the left Tone button sounds quieter.

3. Press the [Metronome/Rhythm] button or the [Variation] button.

The button’s indicator returns to its previous state.

You can also return to the previous state by pressing the [Song] button.

Changing the Depth of the Reverb

The depth of the reverb effect (p. 17) can be adjusted.

There are five levels of depth from which to choose.

This is set to “3” when the power is turned on.

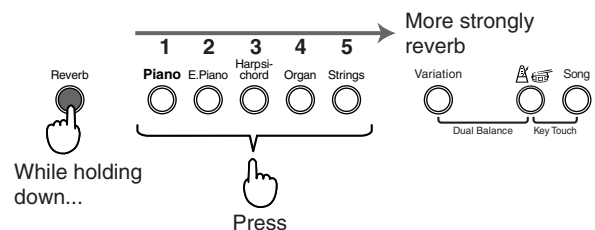

1. Holding down the [Reverb] button, press any Tone button.

■ Checking the depth of the Reverb Effect

1. Press and hold the [Reverb] button.

The Tone button indicators will blink to indicate the selected depth.

Connecting to Audio Equipment

Read this chapter if you wish to connect the F-100 to an audio device.

By connecting the F-100 with an audio device, you can listen to the sound of the F-100 through the speakers of the audio device, or record your performance onto a cassette tape or other recording media.

About the Jacks

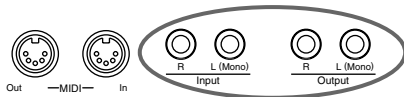

Output Jacks

Use audio cables (sold separately) to connect the F-100 to an audio device so that the sound of the F-100 can be heard from the speakers of the audio device, or so that your performance can be recorded on a cassette tape or other recording media.

Input Jacks

You can use audio cables (sold separately) to connect another audio producing device to the F-100, and hear its sound through the speakers of the F-100.

Making the Connections

NOTE

To prevent malfunction and/or damage to speakers or other devices, always turn down the volume, and turn off the power on all devices before making any connections.

1. Turn the volume down completely on all equipment.
2. Turn off the F-100 and any other devices to be connected.
3. Use audio cables (sold separately) to connect the other device to the F-100.

NOTE

If the device you are connecting is monaural, connect it to the L (Mono) jack. In this case, do not connect the R jack of the F-100.

NOTE

Use a cable from Roland to make the connection. If using some other make of connection cable, please note the following precautions.

Some connection cables contain resistors. Do not use cables that incorporate resistors for connecting to this unit. The use of such cables can cause the sound level to be extremely low, or impossible to hear. For information on cable specifications, contact the manufacturer of the cable.

NOTE

Once the connections have been completed, turn on power to your various devices in the order specified. By turning on devices in the wrong order, you risk causing malfunction and/or damage to speakers and other devices.

- **Listening to the F-100 through the speakers of an audio device, or recording a performance onto a cassette tape or other media**

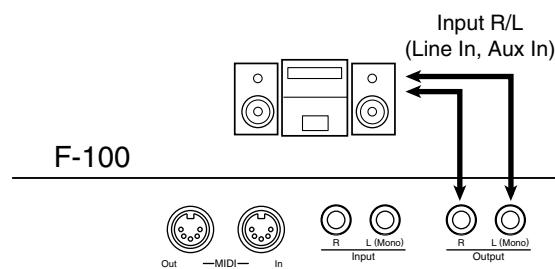

1. Turn on the power to the F-100.
2. Turn on the power to the connected equipment.
3. Adjust the volume.

Recording procedure

1. Start recording on the connected audio device.
2. Begin playing on the F-100.
3. When you finish playing, stop recording.

- **Listening to the sound of an audio device through the speakers of the F-100**

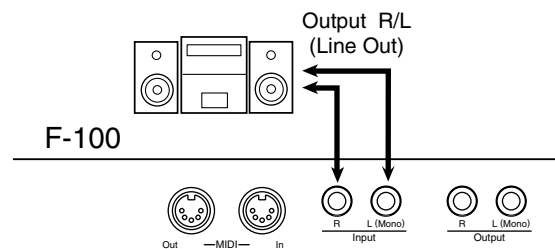

1. Turn on the power to the connected equipment.
2. Turn on the power to the F-100.
3. Adjust the volume.

NOTE

If the volume of any device connected to the Input jacks is raised too high, you not only risk causing damage to your hearing, you could also damage the unit's speakers. It's best to always keep the sound within reasonable levels of volume.

Connecting to MIDI Devices

Read this chapter if you wish to connect the F-100 to an external MIDI device.

If the F-100 is connected to a MIDI sequencer, such as one from the MT series, you can record your performance on the MIDI sequencer. The rich variety of sounds built into the MT series can be played with the keyboard of the F-100.

About MIDI

MIDI, short for “Musical Instrument Digital Interface,” was developed as a standard for the exchange of performance data between electronic instruments and computers.

The F-100 is equipped with MIDI connectors to allow such exchange of performance data with external equipment and devices. Connecting the keyboard to other devices with these connectors provides you with an even greater variety of ways to use your keyboard.

About the MIDI Connectors

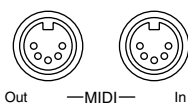

MIDI connectors on the rear panel

MIDI In Connector

Use a MIDI cable (sold separately) to connect from here to the MIDI Out connector on the external MIDI device.

MIDI messages sent from connected external equipment will be received here. As a result, the F-100 will produce sound, change tones, or perform other operations.

MIDI Out Connector

Use a MIDI cable (sold separately) to connect from here to the MIDI In connector on the external MIDI device.

Performance data detailing what has been played on the keyboard, and other data, such as that generated when a pedal is depressed, is sent out from here to external MIDI devices.

Making the Connections

NOTE

To prevent malfunction and/or damage to speakers or other devices, always turn down the volume, and turn off the power on all devices before making any connections.

1. Turn the volume down completely on all equipment.
2. Turn off the F-100 and any other devices to be connected.
3. Use the optional MIDI cable to connect the MIDI connector on the external MIDI device to the MIDI connector on the F-100.
Take a look at the connection examples.
4. Turn on the power to all equipment.
5. Adjust the volume.
6. You should also make the following settings as needed.

For details on making MIDI-related settings for the F-100, refer to p. 31 through p. 32.

Connection Examples:

Connecting to a sequencer (The Roland MT Series)

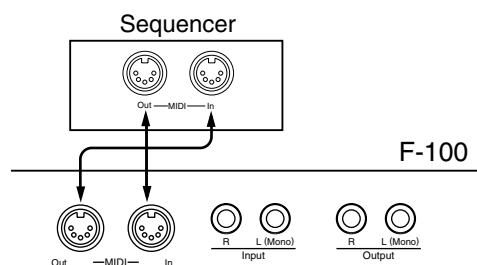

* The MT-90s has no MIDI Out connector.

Connection Examples: Connecting to a MIDI sound module

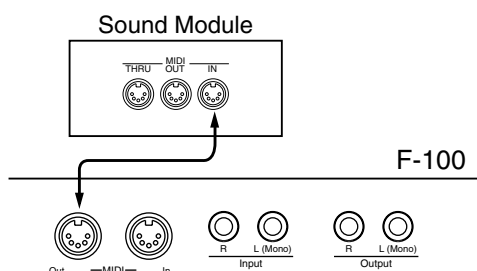

Cautions when Connecting an External MIDI Device

Here we will explain the “Local On/Off” and “Omni On/Off” settings that you need to be aware of when connecting the F-100 to an external MIDI device.

■ Disconnecting the F-100’s keyboard and internal sound generator (Local On/Off)

When the F-100 is connected to a MIDI sequencer or the like, set it to Local Off.

As shown in the diagram, the data that is produced when you play the keyboard will reach the sound generator by two routes, (1) and (2), causing each note to be played in duplicate. To prevent this, select the Local Off setting to cut route (1).

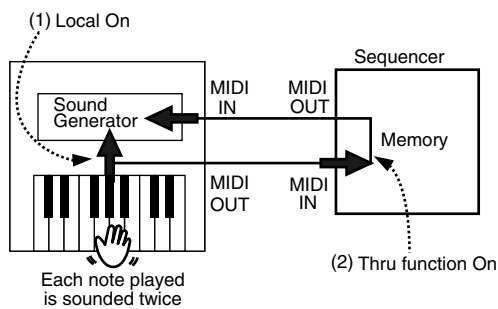

This sets it to Local On:

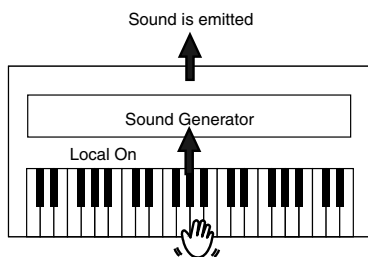

This sets it to Local Off:

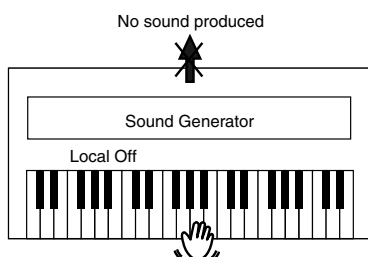

NOTE

Be aware that if you set your instrument to Local Off when no external MIDI device is connected, there will be no sound.

■ Switching Local On/Off

Local On is set when the power is switched on.

1. While holding down the [Variation] button and [Song] button, the “C8” note to turn the setting On, or press the “B7” note to turn the setting Off.

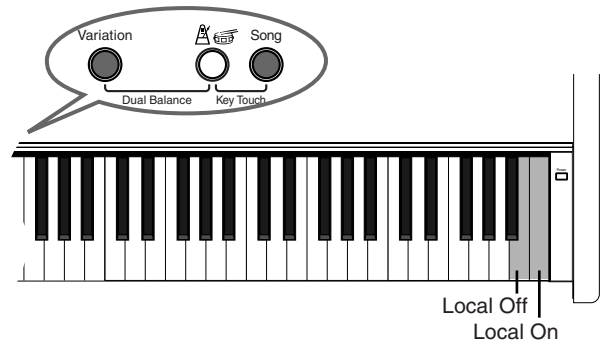

MEMO

If the F-100 is connected to a Roland MT series (except MT-90s), it is not necessary to make the Local Off setting. When the power is turned on, the MT series will transmit a Local Off message. If you turn the power on in the order of first the F-100 and then the MT series, the F-100 will automatically be set to Local Off.

■ Receiving on all MIDI channels (Omni On/Off)

When set to Omni On, the F-100 will sound as a result of received MIDI messages, no matter which channel the messages arrive on.

When set to Omni Off, the F-100 will recognize only the messages that arrive on the MIDI channel that has been selected, as explained under “Set the MIDI Channel.”

■ Switching Omni On/Off

Omni On is automatically set when the power is switched on.

1. Hold down the [Variation] button and [Song] button, and press the “A7” note to turn the setting On, or the “G7” note to turn the setting Off.

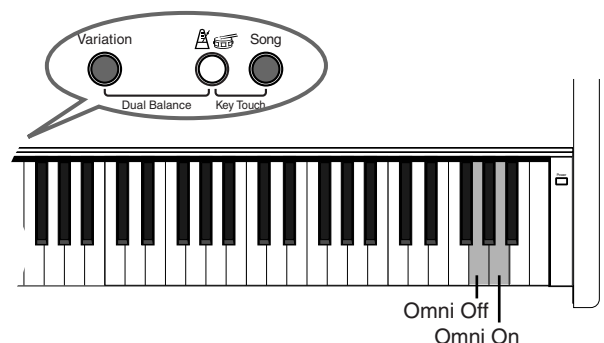

Connecting to MIDI Devices

■ Set the MIDI Channel

MIDI features sixteen MIDI channels, numbered 1–16.

The connected devices must be set to use the same MIDI channels, otherwise no sound will be produced.

In a setup where you wish to play the F-100 and also have another MIDI-equipped instrument or sound module play the same notes, you should first set the channel used for reception on your external device to the same channel that you have the F-100 set to use for transmission.

Upon power-up, the F-100 is set to Omni On (p. 31). This means that if you are using a MIDI keyboard or MIDI sequencer to play the F-100's tones, messages will be received on all channels, regardless of any MIDI channel settings. If you want to receive only on a specific channel that a connected MIDI device will be using, switch the F-100 to Omni Off, then set the MIDI channel.

When the F-100 is turned on, Channel "1" is selected.

1. While holding down the [Variation] and [Song] buttons, press the appropriate key (C5–D#6) on the keyboard.

The MIDI transmit channel and receive channel will switch to the number that corresponds to the note you pressed.

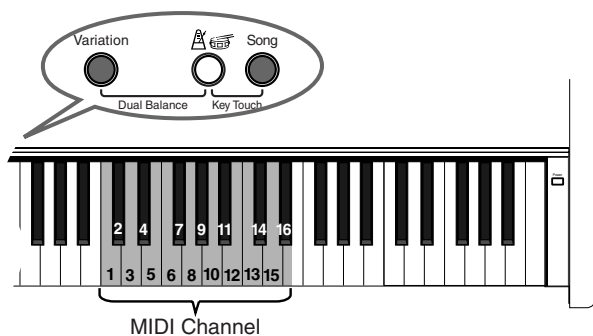

■ Transmitting a performance you recorded

If you want to transmit a performance recorded on the F-100 to an external MIDI device or computer, turn this setting "On." If this is "Off," the data will not be transmitted.

When the F-100 is turned on, "Off" is selected.

1. While holding down the [Variation] and [Song] buttons, press the "D7" note to turn the setting On, or the "C7" note to turn the setting Off.

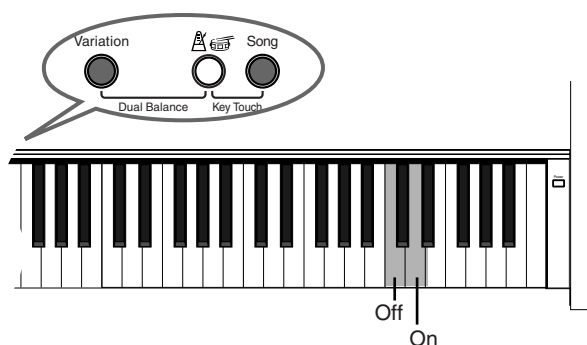

If you wish to save the performance, use the following procedure. In this situation, your external sequencer is set its MIDI Thru feature to be OFF. For details, refer to the owner's manual of your MIDI sequencer.

1. Connect a MIDI sequencer such as the MT series (p. 30).
2. Record the performance on the F-100 (p. 21).
3. Set this setting to "On."
4. Start recording with the connected MIDI device.
5. Start playback of the recorded song on the F-100.
6. When playback ends, stop recording with the connected MIDI device.
7. Use a connected MIDI sequencer to save the data on a floppy disk or other media.

Troubleshooting

If you are encountering problems with the unit, please read the section below before assuming that there is a malfunction.

Case	Cause/Remedy
The piano cannot be switched on	Is the AC adaptor properly connected? (p. 10)
No sound is produced	Is the [Volume] knob set to the minimum position? (p. 12)
	Are the headphones connected? (p. 12)
	Is Local On/Off set to "Off"? (p. 31)
	Is the speaker cable properly connected? (p. 6)
Only One Tone Plays in Dual Play	Depending on the setting for volume balance, and the particular selection of tones you make, certain tones may be difficult to hear when layered. Try adjusting volume balance (p. 28).
Internal songs do not play	Is Panel Lock on? (p. 26)
Buttons do not function	
Keyboard sound does not change	
Two sounds are produced when the keyboard is played	Is the keyboard in Dual Play mode? (p. 16)
The tone has changed in the Dual Play	If you use Dual Play with a Tone button for which tone number 3 or 4 is selected, tone number 1 will be selected for that Tone button (p. 15).
The pitch of the keyboard sounds incorrect	Is the Master Tuning setting correct? (p. 27)
	Is the Key Transpose setting correct? (p. 27)
Song doesn't play back/ Only the sound of a particular part in a song does not play	Are the indicator for the [1] or [2] button extinguished, when you press the [Track] button? (p. 14) If the button indicator is out, the music on that track is not heard. Hold down the [Track] button and press the [1] or [2] button, illuminating its indicator.
Rhythm doesn't sound	It is not possible to sound the rhythm while an internal song is playing back or recording.
	A performance that was recorded using metronome cannot be played back with the rhythm.
Metronome does not sound	Is Panel Lock on? (p. 26)
	A performance that was recorded using rhythm cannot be played back with the metronome.
	If Rhythm is selected, the metronome will not sound even if you press the button. Please re-select the beat (time signature) of the metronome (p. 19).
Tempo of recorded song or metronome is off	If you select an internal song in which the tempo changes during the song, and then record, the tempo will change in the same way for the performances. The tempo of the metronome will also change in the same way.
	If you record additional material without erasing the previously recorded song, the song will be recorded at the first-recorded tempo. Please erase the previously recorded song before you re-record (p. 25).
The recorded performance has disappeared	Any performance that has been recorded is deleted when the power to the F-100 is turned off. A performance cannot be restored once it's been deleted.
Sound is distorted	Raising the volume too high may distort the sound. Adjust the volume level with the [Volume] knob (p. 12).

Case	Cause/Remedy
In the upper range, the sound changes abruptly beyond a certain key	On an acoustic piano, notes in the upper one and a half octaves of the keyboard continue to sound until they decay naturally, regardless of the damper pedal. There is a difference in the timbre as well. Roland pianos faithfully simulate such characteristics of the acoustic piano. On the F-100, the range that is unaffected by the damper pedal will change depending on the Key Transpose setting.
A High-pitched whine is produced	<p>When listening through headphones:</p> <p>Some of the more flamboyant and effervescent piano tones feature an ample high-end component, which may make the sound appear to have metallic reverberation added. Since this reverberation becomes particularly audible when supplemented by heavy reverb, you may be able to diminish the problem by reducing the amount of reverb applied to the sound.</p> <p>When listening through speakers:</p> <p>Here, a different cause (such as resonance produced by the F-100) would be suspect. Consult your Roland dealer or nearest Roland Service Center.</p>
Bass notes sound wrong/buzzing or vibration occurs	<p>If you can't hear the problem in the headphones:</p> <p>When playing at high volumes, resonance may occur in the piano itself or in objects near the piano. At times, other objects in the room, such as fluorescent lights or glass doors, could start vibrating. Such phenomenon becomes more prevalent when sounding the lower frequencies at high volume. To minimize such unwanted resonance, please observe the following:</p> <ul style="list-style-type: none"> - Locate the instrument so it is 10-15 cm away from walls. - Reduce the volume. - Increase the distance from the object that is resonating. - Place the keyboard lid farther away from the piano. <p>If you can hear the problem in the headphones:</p> <p>The problem may be for a different reason. Please contact your dealer.</p>
The pedals are not functioning, or function intermittently	Are the pedals connected properly? (p. 10)
When the F-100 is connected to an external device	
No sound is produced	Is the power to all equipment turned on?
	Are the connections between F-100 and the MIDI sequencer or the other external devices correct? (p. 29, p. 30)
	Is the MIDI channel setting correct? (p. 32)
	Is the Omni On/Off setting correct? (p. 31)
Strange sounds (or two sounds) are produced when the F-100 is played	With the sequencer's "Thru" function on, the same notes may be sounded twice. Set the F-100 to Local off (p. 31).
The volume level of the instrument connected to the Input jack is too low.	Could you be using a connection cable that contains a resistor? Use a connection cable that does not contain a resistor.

Internal Song List

→ “Listening to the Internal Songs” (p. 13)

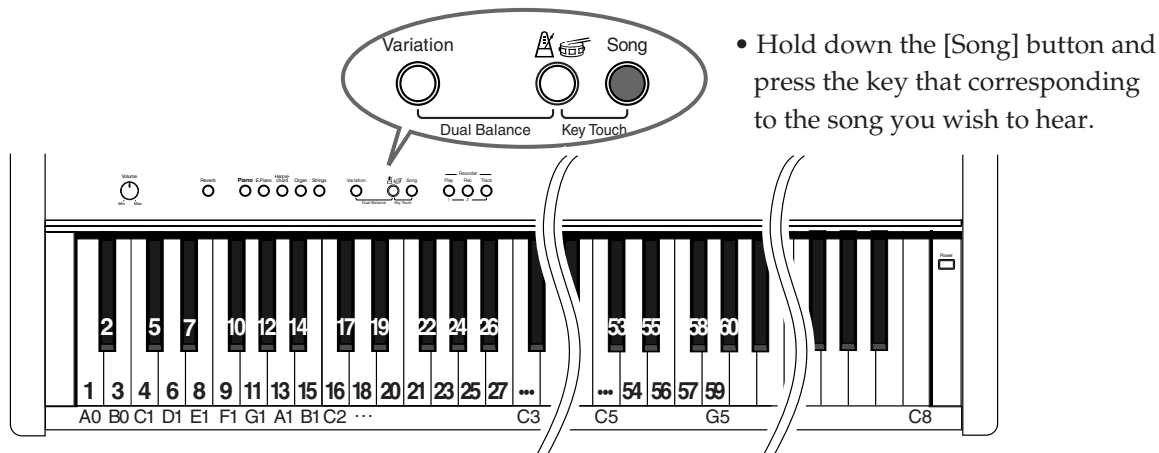

No.	Key	Song Name	Composer	Copyright
1	A0	1ère Arabesque	C. Debussy	© 1995 Roland Corporation
2	Bb0	Sonate für Klavier No. 15	W. A. Mozart	© 1996 Roland Corporation
3	B0	1ère Gymnopédie	E. Satie	© 1997 Roland Corporation
4	C1	Golliwog's Cake walk	C. Debussy	© 1995 Roland Corporation
5	Db1	Liebesträume III	F. Liszt	© 2001 Roland Corporation
6	D1	Je te veux	E. Satie	© 1997 Roland Corporation
7	Eb1	Étude, op.10-3	F. Chopin	© 2001 Roland Corporation
8	E1	Clair de Lune	C. Debussy	© 1998 Roland Corporation
9	F1	Valse, op.64-1	F. Chopin	© 2001 Roland Corporation
10	F#1	Fantaisie-Impromptu	F. Chopin	© 2001 Roland Corporation
11	G1	An der schönen, blauen Donau	J. Strauss	© 1996 Roland Corporation
12	Ab1	Auf Flügeln des Gesanges	F. Mendelsshon	© 1996 Roland Corporation
13	A1	Mazurka No.5	F. Chopin	© 1995 Roland Corporation
14	Bb1	Étude, op.25-1	F. Chopin	© 1995 Roland Corporation
15	B1	Étude, op.10-5	F. Chopin	© 2001 Roland Corporation
16	C2	Doctor Gradus ad Parnassum	C. Debussy	© 1995 Roland Corporation
17	Db2	Grande Valse Brillante	F. Chopin	© 1995 Roland Corporation
18	D2	La prière d'une Vierge	T. Badarzewska	© 1996 Roland Corporation
19	Eb2	Course en Troïka	P. Tchaikovsky	© 1996 Roland Corporation
20	E2	To The Spring	E. Grieg	© 1996 Roland Corporation
21	F2	Valse, op.64-2	F. Chopin	© 1996 Roland Corporation
22	F#2	Radetzky Marsch	J. Strauss	© 1996 Roland Corporation
23	G2	Träumerei	R. Schumann	© 1996 Roland Corporation
24	Ab2	Moments Musicaux III	F. Schubert	© 1996 Roland Corporation
25	A2	Prélude, op.28-15	F. Chopin	© 1996 Roland Corporation
26	Bb2	The harmonious blacksmith	G. Handel	© 1996 Roland Corporation
27	B2	Ungarische Tänze V	J. Brahms	© 1996 Roland Corporation

Internal Song List

No.	Key	Song Name	Composer	Copyright
28	C3	Türkischer Marsch (Beethoven)	L. v. Beethoven	© 1996 Roland Corporation
29	Db3	Nocturne No.2	F. Chopin	© 1996 Roland Corporation
30	D3	Frühlingslied	F. Mendelsshon	© 1996 Roland Corporation
31	Eb3	Präludium	J. S. Bach	© 1996 Roland Corporation
32	E3	Jägerlied	F. Mendelsshon	© 1996 Roland Corporation
33	F3	Menuet Antique	M. Ravel	© 1996 Roland Corporation
34	F#3	Für Elise	L. v. Beethoven	© 1996 Roland Corporation
35	G3	Türkischer Marsch (Mozart)	W. A. Mozart	© 1996 Roland Corporation
36	Ab3	Ständchen	F. Schubert	© 1996 Roland Corporation
37	A3	Humoreske	A. Dvorjak	© 1996 Roland Corporation
38	Bb3	Blumenlied	G. Lange	© 1996 Roland Corporation
39	B3	Alpenglöckchen	T. Oesten	© 1996 Roland Corporation
40	C4	Menuett G dur (Beethoven)	L. v. Beethoven	© 1996 Roland Corporation
41	Db4	Venezianisches Gondellied	F. Mendelsshon	© 1996 Roland Corporation
42	D4	Alpenabendröte	T. Oesten	© 1996 Roland Corporation
43	Eb4	Farewell to the Piano	L. v. Beethoven	© 1996 Roland Corporation
44	E4	Brautchor	W. Wagner	© 1996 Roland Corporation
45	F4	Battle of Waterloo	W. Anderson	© 1996 Roland Corporation
46	F#4	Wiener Marsch	C. Czerny	© 1996 Roland Corporation
47	G4	Le Coucou	L. C. Daquin	© 1996 Roland Corporation
48	Ab4	Menuett G dur (Bach)	J. S. Bach	© 1992 Roland Corporation
49	A4	Spinnerlied	A. Ellmenreich	© 1996 Roland Corporation
50	Bb4	Gavotte	F. Gossec	© 1996 Roland Corporation
51	B4	Heidenröslein	G. Lange	© 1996 Roland Corporation
52	C5	Zigeuner Tanz	H. Lichner	© 1996 Roland Corporation
53	Db5	La Cinquantaine	G. Marie	© 1996 Roland Corporation
54	D5	Csikos Post	H. Necke	© 1996 Roland Corporation
55	Eb5	Dolly's Dreaming Awakening	T. Oesten	© 1996 Roland Corporation
56	E5	La Violette	L. Streabbog	© 1996 Roland Corporation
57	F5	Fröhlicher Landmann	R. Schumann	© 1996 Roland Corporation
58	F#5	Sonatine op.36-1 (Clementi)	M. Clementi	© 1996 Roland Corporation
59	G5	Sonatine op.20-1 (Kuhlau)	F. Kuhlau	© 1996 Roland Corporation
60	Ab5	Sonatine No.5 (Beethoven)	L. v. Beethoven	© 1996 Roland Corporation

** All rights reserved. Unauthorized use of this material for purposes other than private, personal enjoyment is a violation of applicable laws.*

MIDI Implementation Chart

Function...	Transmitted	Recognized	Remarks
Basic Channel Default Changed	1 1-16	1 1-16	
Mode Default Messages Altered	Mode 1 x *****	Mode 1 OMNI ON/OFF	
Note Number : True Voice	15-113 *****	0-127 15-113	
Velocity Note ON Note OFF	O x 8n v=64	O x	
After Touch Key's Ch's	x x	x x	
Pitch Bend	x	x	
Control Change 6, 38 7 11 64 66 67 91 100, 101	O x x O x O O O	O O *1 O *1 O *1 O *1 O *1 O O	Data entry Volume Expression Hold 1 Sostenuto Soft Effect1 depth (Reverb) RPN LSB, MSB
Prog Change : True Number	O (0...64) *****	O (0-127) 0...64	
System Exclusive	O	O	
System Common : Song Pos : Song Sel : Tune	x x x	x x x	
System Real Time : Clock : Commands	x x	x x	
Aux Message : All sound off : Reset all controllers : Local ON/OFF : All Notes OFF : Active Sense : System Reset	x x x x O x	x O O O (123-127) O x	
Notes	*1 This message can affect only MIDI notes.		

Mode 1 : OMNI ON, POLY Mode 2 : OMNI ON, MONO O : Yes
Mode 3 : OMNI OFF, POLY Mode 4 : OMNI OFF, MONO X : No

* A separate publication titled "MIDI Implementation" is also available. It provides complete details concerning the way MIDI has been implemented on this unit. If you should require this publication (such as when you intend to carry out byte-level programming), please contact the nearest Roland Service Center or authorized Roland distributor.

Main Specifications

F-100: Roland Digital Piano

Keyboard

Keyboard

88 keys (Progressive Hammer Action Keyboard)

Touch Sensitivity

Light, Medium, Heavy, Fixed

Keyboard Mode

Whole

Dual (adjustable volume balance)

Sound Generator

Maximum Polyphony

64 voices

Tones

5 groups 20 variations

Effects

Reverb (5 levels)

Chorus (fixed for E. Piano only)

Sympathetic Resonance (fixed for Piano only)

Key Transposition

-6 to +5 (in units of semitone)

Master Tuning

415.3 Hz to 466.2 Hz (adjustable in increments of 0.1 Hz)

Metronome, Rhythm

Beat

0, 2, 3, 4, 6

Rhythm

16 patterns

Volume

5 levels

Recorder

Tracks

2 tracks

Song

1 song

Note Storage

Approx. 5,000 notes

Tempo

Quarter note = 20 to 250

Resolution

96 ticks per quarter note

Control

Play/Stop, Rec, Tempo, All Song Play, Track Select

Preset Songs

60 songs

Others

Speakers

12 cm x 2

Rated Power Output

5 W x 2

Pedals

Damper, Soft

Connectors

Headphones Jack (Stereo miniature phone type) x 2

MIDI Connectors (In, Out)

Output Jacks (L/Mono, R)

Input Jacks (L/Mono, R)

Pedal Jacks (Damper, Soft)

Power Supply

DC 9 V (AC Adaptor)

Current Draw

2,000 mA

Dimensions (without the music stand)

1,337 (W) x 295 (D) x 772 (H) mm

52-11/16 (W) x 11-5/8 (D) x 30-7/16 (H) inches

Weight

39 kg / 86 lbs

Accessories

Owner's Manual

Tempo Setting Sheet

AC Adaptor

AC Cord

Music Stand

Lid

Lid Holder

* In the interest of product improvement, the specifications and/or appearance of this unit are subject to change without prior notice.

Functions Assigned to the Keyboard

Functions for Metronome/Rhythm

• While holding down the [Metronome/Rhythm] button, press the corresponding key.

Changing the Beat (p. 19) Specifying the Rhythm (p. 20) Specifying the Tempo (p. 18)

Other Functions

• While holding down the [Variation] button and [Song] button, press the corresponding key.

Key Transpose (p. 27) Master Tuning (p. 27) Setting the MIDI Channel (p. 32) Transmission of playback data On/Off (p. 32) Omni On/Off (p. 31) Local On/Off (p. 31)

Index

Numerics

440.0 Hz	28
442.0 Hz	28

A

AC Adaptor	10
Assembly	6
Audio Equipment	29

B

Beat	19
------------	----

C

Connecting	
Audio Equipment	29
MIDI Devices	30

D

Damper Pedal	10
Demo Song	34
Dual Play	16, 28
Volume Balance	28

E

Erase	25
-------------	----

H

Headphones	12
------------------	----

I

Input Jacks	29
Internal Songs	13

K

Key Transpose	27
Keyboard's Touch	26

L

Lid	11
Local On/Off	31

M

Master Tuning	27
Metronome	17
[ (Metronome/Rhythm)] Button	17
MIDI	30
Transmitting a performance	32
MIDI Channel	32
MIDI Devices	30
MIDI In Connector	30
MIDI Out Connector	30
Music Stand	10

O

Omni On/Off	31
Output Jacks	29

P

Panel Lock	26
Pedal	10
Playback	13
Each Hand	14
Power	12
[Power] Switch	12

R

Record	21
Along with a Song	23
Along with the Rhythm	22
Each Hand	24
Erasing Performances	25
New Song	21
Reference Pitch	27
[Reverb] Button	17
Reverb Effect	17
Changing the Depth of the Reverb	28
Rhythm	20

S

Soft Pedal	10
[Song] Button	13
Speaker Cable	7

T

Tempo	18
Tempo Setting Sheet	8
Tone	15
Tone Button	15
Touch Sensitivity	26
Track button	14
[Track] Button	14
Transmitting a performance	32
Transpose	27
Tuning	27

V

[Variation] Button	15
Volume	
Metronome/Rhythm	19
Overall	12
[Volume] Knob	12

MEMO

MEMO



This product complies with the requirements of European Directive 89/336/EEC.

For EU Countries

FEDERAL COMMUNICATIONS COMMISSION RADIO FREQUENCY INTERFERENCE STATEMENT

For the USA

This equipment has been tested and found to comply with the limits for a Class B digital device, pursuant to Part 15 of the FCC Rules. These limits are designed to provide reasonable protection against harmful interference in a residential installation. This equipment generates, uses, and can radiate radio frequency energy and, if not installed and used in accordance with the instructions, may cause harmful interference to radio communications. However, there is no guarantee that interference will not occur in a particular installation. If this equipment does cause harmful interference to radio or television reception, which can be determined by turning the equipment off and on, the user is encouraged to try to correct the interference by one or more of the following measures:

- Reorient or relocate the receiving antenna.
- Increase the separation between the equipment and receiver.
- Connect the equipment into an outlet on a circuit different from that to which the receiver is connected.
- Consult the dealer or an experienced radio/TV technician for help.

This device complies with Part 15 of the FCC Rules. Operation is subject to the following two conditions:

- (1) This device may not cause harmful interference, and
- (2) This device must accept any interference received, including interference that may cause undesired operation.

Unauthorized changes or modification to this system can void the users authority to operate this equipment.
This equipment requires shielded interface cables in order to meet FCC class B Limit.

For Canada

NOTICE

This Class B digital apparatus meets all requirements of the Canadian Interference-Causing Equipment Regulations.

AVIS

Cet appareil numérique de la classe B respecte toutes les exigences du Règlement sur le matériel brouilleur du Canada.

This owner's manual is printed on recycled paper.