

USING
the
SEQUENCER

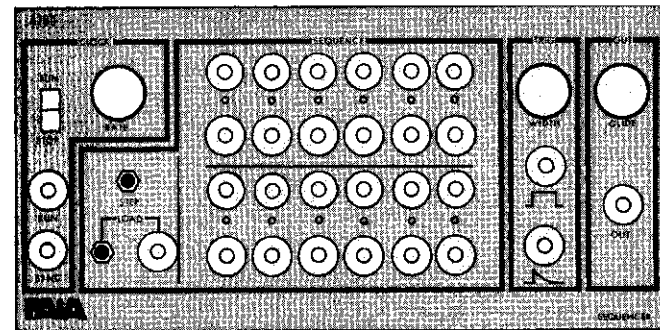

TESTING AND CALIBRATION

There is only one calibration point in the 4780 Sequencer so this procedure will be predominantly concerned with establishing that the module is operating properly.

Begin by applying power to the 4 flea clips on the rear edge of the "B" circuit board; +13 volts to the point marked "++", +9 volts to the "+", -9 volts to the "-" and the ground clip to the common ground of the supplies. Notice that the +13 volt supply must be capable of supplying a hefty (for this equipment) 50 ma. of current. Suitable power supplies are the PAIA 272D-7 or two 4770 modules.

Begin by setting the front panel controls as follows: Clock rate fully counter-clockwise (CCW). Run/Stop switch fully down to "stop". Trigger width fully clockwise (CW). Glide fully CCW. All pitch controls (small black knobs in the SEQUENCE box) fully CCW - note that these are multi-turn controls that have a built in ratchet at the extremes of their range. Set the "duration trim" trimmer on the upper 4780/A circuit board fully CW as viewed from the rear of the module.

Press the "load" push button and observe that the Light Emitting Diode in the left-most position of the upper row of LED's comes on and stays on. This should be the only LED lighted at this point. Repeatedly press the "step" push button and observe that each of the LED's light in turn proceeding to the right in both of the two rows. When the last LED (right-most on bottom row) extinguishes there should be no LED's lighted. Observe that each time the "step" button is pressed, the single LED in the Trig. box blinks momentarily.

Using a Volt-ohm meter, measure the voltage between the "Out" jack and ground. Observe that as each stage is turned on, the pitch control for that stage can vary the output voltage from essentially zero volts to over 5 volts. Return each pitch control to its fully CCW limit after each measurement is made.

Slide the Run/Stop switch fully up to the "Run" position and observe that each of the LED's light in sequence ending with no LED's lit as the last indicator extinguishes. Note that the single LED in the Trig. box continues to flash even though none of the LED's in the SEQUENCE box are on. Slowly rotate the adjusting disk of the "duration trim" trimmer on the 4780/A board in a CCW direction (as viewed from the rear of the module) until the point is reached at which the LED in the Trig. box glows constantly, then back off in a CW direction until the indicator can be observed to wink off briefly during each clock cycle. Rotate the front panel Width control in a CCW direction and observe that as this control is retarded the indicator LED remains on for an increasingly brief portion of each clock cycle.

Slide the Run/Stop switch to its mid position between "Run" and "Stop" and observe that the trigger indicator LED stops flashing. Press the "load" push button and notice that the first stage of the counter loads (as indicated by the LED associated with that stage) and that the count progresses at a uniform rate through the counter. Observe that the trigger indicator LED blinks while the counter is working but goes off as the last stage status indicator extinguishes.

Use a short jumper to connect the last (right-most in lower row) red stage output pin jack to the "load" input jack. Slide the Run/Stop slide switch fully up to the "run" position and observe that the count "circulates", i. e. that as the last stage indicator extinguishes the first stage indicator comes on. Advance the CLOCK Rate control in a clockwise direction and observe that as this control is advanced the count progresses at an increasing rate. Slide the switch to the "stop" position and observe that the clock stops (as indicated by the Trig. indicator LED remaining off) and that none of the LED's in the SEQUENCE box are lit.

Remove the jumper from the last stage of the counter and re-connect it to the second-to-last jack in the chain. Switch the Run/Stop switch to "Run" and observe that the count circulates but that the last stage in the counter does not come on. Move the jumper back one more jack, start the clock and observe that the last two stages do not activate.

Continue moving the jumper back one jack at a time and each time observe that the count progresses no further than the stage corresponding to the jack which is connected to the "load" input. NOTE: connecting the first stage of the counter to the "load" input will produce no results.

USING THE PAIA 4780 SEQUENCER

CONTROL OPERATION

The front panel graphics of the 4780 divide the controls into four logical groupings:

- 1) Clock
- 2) Sequence
- 3) Trigger (Trig.)
- 4) Output (Out.)

Operation of the controls within these groupings is as follows:

CLOCK

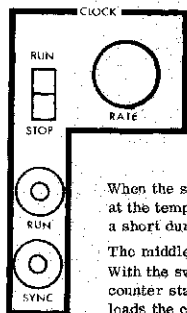

Rate The rate control sets the tempo of the sequencer's internal clock. Clockwise rotation of the control increases the tempo.

Run/Stop switch This is a three position slide switch. When the switch bat is fully down to the "stop" position the clock is stopped from free running. Changing the switch to "stop" from either of the other two positions generates a short duration pulse that clears the counter.

When the switch is set fully up to the "run" position the clock runs unconditionally at the tempo set by the RATE control. Moving the switch to the run position generates a short duration pulse that loads the first stage of the counter.

The middle position of the switch can be considered to be a "conditional run" setting. With the switch in this position the clock will free run only when one or more of the counter stages are loaded. Moving the switch to this position neither clears nor loads the counter.

Run input The pin jack immediately below the Run/Stop switch provides an electrical input that loads the first stage of the counter and duplicates the action of setting the Run/Stop switch to the "conditional run" position (clock runs while counter is loaded but stops when counter clears).

Sync The Sync input allows the sequencer clock to be synchronized with other clocks in a system (e.g. another sequencer). This input is active only when the Run/Stop switch is in the "stop" position. If the RATE control is set such that the clock would be running as fast or faster than the synchronization source then there will be one clock pulse for every synchronizing pulse. Setting the rate control such that the clock would be running slower than the synchronizing source produces a dividing action that causes the sequencer clock to pulse once for every two, three or more synchronization source pulses.

SEQUENCE

Load There are both electrical and manual provisions for loading the first stage of the counter, some of which have been covered in CLOCK controls explanation. The LOAD push button and pin jack contained in the SEQUENCE box of the panel graphics allow the counter to be loaded without changing the clock status. It is important to note that the first stage of the counter loads on the trailing (falling) edge of pulses applied to the LOAD pin jack.

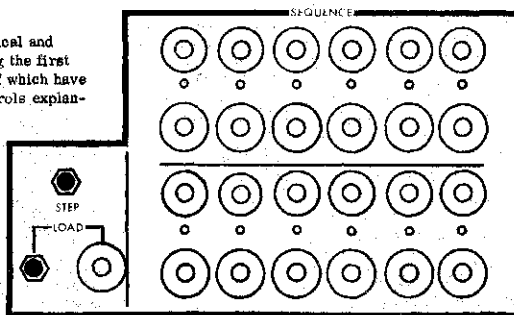

Step The step push button is essentially a manual substitute for the clock. Pressing this button causes the count to advance by one stage.

Pitch There are 12 unlabeled pitch controls (small black knobs). While there is some very slight interaction of these controls which will not be noticeable under normal circumstances,

each control is active only when the corresponding stage of the ring counter is loaded. Turning the knobs of these 25 turn controls in a clockwise direction increases the control voltage present at the output jack.

Status LEDs Below each pitch control is a Light Emitting Diode which glows to indicate that a stage is loaded and active.

Stage Outputs The 12 red pin jacks in the SEQUENCE box are pulse outputs associated with each stage. As each stage is loaded approximately 15 volts appears at the pin jack associated with that stage. This voltage remains high as long as the stage is active and drops to essentially zero when the stage turns off.

TRIGGER



Width The width control in the TRIG. box allows the step trigger output jack to be at a high voltage state for a period of time that is a fixed percentage of the time between clock pulses. Turning the control in a clockwise direction increases the "duty factor" (percentage of "on" time to "off" time) of the step trigger output.

Step Trigger (□) The red pin jack directly below the Width control is the step trigger output. The voltage at this jack rises as described above. Within the step trigger symbol (□) is a Light Emitting Diode that indicates both clock rate and duration of the step trigger pulse. This LED is lit whenever the step trigger output is high.

Pulse Trigger (⏏) The red pin jack marked with the pulse symbol is the output for a short duration pulse that occurs on the leading (rising) edge of each step trigger.

OUTPUT

Glide The Glide control inside of the output box provides for glissando between changes in control voltage output. Turning this control in a clockwise direction increases the time required for the voltage to change from one level to another.

Out The red pin jack directly below the Glide control is the control voltage output of the sequencer.

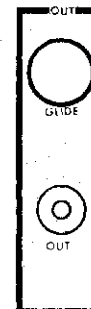

USING THE SEQUENCER

Figure 1 shows what will be by far the most common patching arrangement between the 4780 and external processing modules. The control voltage output of the sequencer is driving a VCO while either of the trigger outputs (step or pulse) are acting as trigger sources to a function generator which is in turn varying the gain of a Voltage Controlled Amplifier.

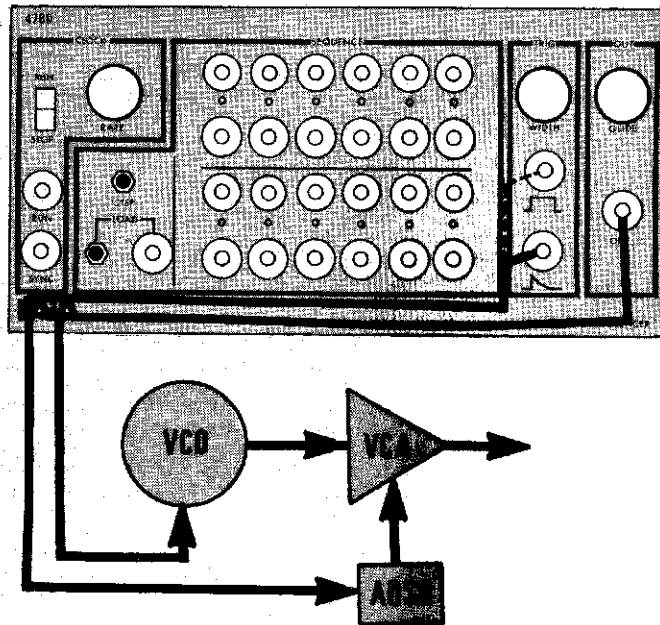

Figure 1 - COMMON SEQUENCER PATCH

The pitch that will be produced by each stage of the sequencer would ordinarily be set by using the LOAD pushbutton to load the counter then STEP ing through all the stages while setting the pitch of the oscillator as desired using the sequencer's pitch controls. Sliding the run/stop switch to RUN will produce a single run of notes at the rate set by the RATE control.

Using the run/stop switch set to the RUN position for single sequence run (non-recirculating) is a bad idea for one very important reason. The clock continues to run whether the counter section is actually counting or not. So what's so wrong with that? Just this, as long as the clock section is running it is also triggering the function generator which in turn is turning the VCA on and off. For some settings of the stage pitch controls there is a residual output voltage from the sequencer which keeps the oscillator going at a very low pitch. This is very annoying if what you actually want is a single run of notes and then quiet. Even if there is no residual tone from the oscillator, most VCAs make a little noise (pops, hisses, etc.) while they're working. As long as there is a tone input the little operating noises are not objectionable but, when there is no input to mask them they stand out like a topless dancer at a prayer meeting.

A better choice for single sequence runs is to set the run/stop switch to its intermediate "conditional run" position and then start the counter by LOADING the first stage. Now the

counter will go through a single twelve note sequence and then stop -- completely, not even trigger pulses will be generated.

Re-circulating sequences do not present this problem since they are meant to run until the run/stop switch is set to "stop" which both clears the counter and stops the clock anyway. Still, even re-circulating counts can be initiated by setting the R/S switch to "conditional run" and then "load"ing when ready for the sequence. This has some distinct advantages when using multiple sequencers as we shall soon see.

As we saw in the unit's verification procedure, producing a continuous sequence of notes is simply a matter of determining how many notes you want in the sequence and then counting down that many stages before jumping the stage output back into the "LOAD" input. For example, to produce a continuing six note sequence, the sixth stage of the counter would be jumpered back into the "load" input as shown in figure 2.

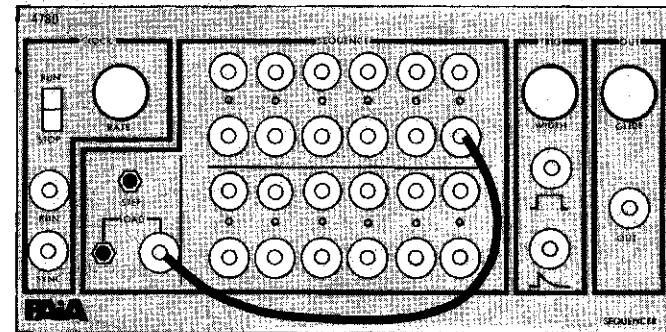

Figure 2 - SEQUENCER SET FOR 6 STEP RECIRCULATING COUNT

Even the simple connection shown in figure 1 presents a large number of variables that are under your direct control and we heartily recommend playing for a time with this single patch while making the count single run or re-circulate, varying the tempo from slow to fast, using both the pulse trigger output of the sequencer and the step trigger at various settings of the WIDTH control, advancing or retarding the GLIDE, setting various pitches at each stage. Also, don't neglect the controls that are external to the Sequencer, you've got Attack, Decay, Sustain and Release of the Envelope Generator and a variety of oscillator waveforms to listen to. All this playing could burn up a lot of time (you could get hooked and never want to stop) but as you go along you'll notice that very subtle changes in the configuration of this patch's controls can make marked differences in the sounds that are produced.

The RUN and SYNCH inputs to the sequencer's clock are most useful with multiple sequencer configurations but they also can be used to tie the sequencer to a keyboard. Let's look at some examples.

Figure 3 shows the pulse output of a keyboard connected to the sequencer's SYNCH input. As is shown, the R/S switch in this application must be left at the STOP position to produce the following result; as long as the counter is not LOADED, nothing happens and the VCO that is connected to the sequencer is silent because there are no trigger pulses originating from the sequencer. The keyboard, whose control voltage would go to a second oscillator, can be played manually as usual. Once the counter is LOADED, the count will advance by one stage each time a key is pressed on the keyboard and each time the keys are pressed a trigger pulse will be generated by the sequencer to activate its associated envelope generator

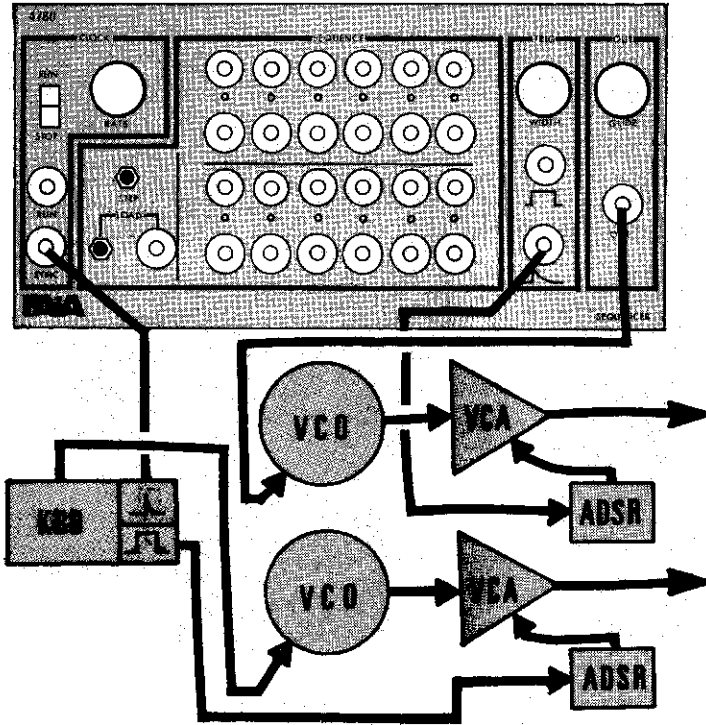

Figure 3 - SYNCHRONIZING SEQUENCER TO KEYBOARD

and VCA. In other words, you have a pre-programmable harmony generator that will stay in synch with the keyboard and can be called up as required by LOADING. As usual, the count can be made to re-circulate by terminating the desired stage back into the LOAD input jack but then the R/S switch must be set to STOP to silence the patch.

There are two ways that a keyboard or other manual controller can be used to initiate an automatic arpeggio using either the RUN or LOAD inputs. In both instances the step trigger pulse of the manual controller is the best choice of trigger but pulse triggers also produce interesting effects.

Using the step trigger output of the manual controller as an input to the RUN jack requires that the R/S switch be set to STOP and results in a twelve step arpeggio each time a key is pressed on the keyboard. In this case the arpeggio begins as soon as the key goes down.

Perhaps more useful is to have an arpeggio result from releasing a key so that the selected note on the keyboard is played followed by the sequencer run. This effect can be produced by setting R/S to "conditional run" and jumpering the step output of the keyboard into the LOAD input of the sequencer (remember, we said earlier that the counter loads on the trailing edge of pulses input to the LOAD jack. (see figure 4)

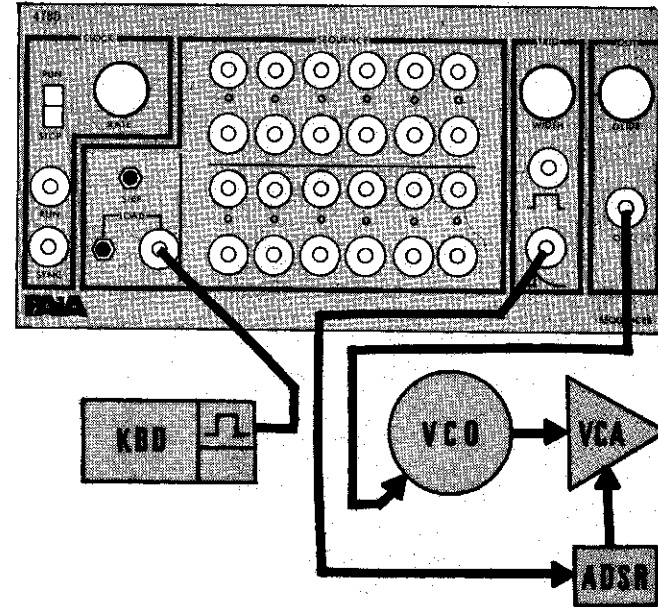

Figure 4 - GENERATING ARPEGGIO AS EACH KEYBOARD KEY IS RELEASED

MULTIPLE SEQUENCERS

As with many other things, if one sequencer is neat - multiple sequencers are really terrific! Two or more sequencers can be combined in ways that will produce long predictable sequences or in other ways that will produce even longer more-or less random sequences.

Chaining two or more sequencers so that they act like one long sequencer is simply a matter of jumpering the output of one sequencer into the LOAD input of the next as shown in figure 5. If you are not using synchronization between the two sequencers, then it is desirable that both R/S switches be set to their CONDITIONAL RUN position. Under these conditions the clock of each sequencer is inactive until the counter associated with it is loaded so each sequencer should be triggering its own function generator (note that the two function generators can be both driving the same VCA if desired). The big advantage here is that the two sequencers can be set to run at entirely different rates so that the first sequencer plays (for example) at a slow rate followed by a very rapid run when the second sequencer is activated.

If you want the two sequencers to run at the same rate you can arbitrarily designate one as the "master" and the other(s) as slave units. In this case, the step (or pulse, whichever is not being used to drive function generators) output of the "master" ties back to the SYNCH inputs of the slave units. In this configuration, the R/S switch of the "master" unit must be set to RUN so that its clock is working whether its counter is loaded or not - you need those clock pulses to drive the slave units whose R/S switch should be set to STOP. To be perfectly in synch, the rate controls of the slave units should be set slightly faster than the rate of the master. Retarding the slave units RATE controls will cause them to trigger on alternate (or every third, fourth, etc.) pulses from the "master" clock so that the two (or more) sequencers can run at different - but still synchronized - rates.

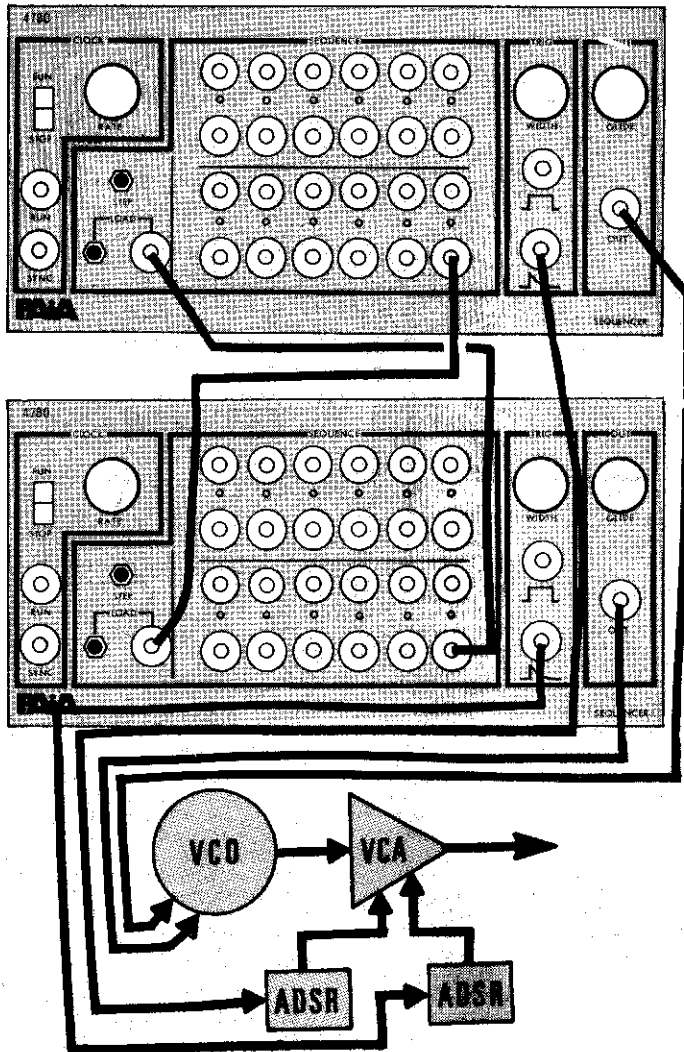

Figure 5 - CHAINING SEQUENCERS

LOADING pulses to chained sequencers don't have to come from the last stage of either "master" or "slave" units and picking up a load pulse from the middle of a sequence produces some interesting situations in which both - or all - of the sequencers are loaded and running for part of the cycle. This produces some particularly interesting effects when the sequencers are not synchronized to one another.

We could go on explaining different interconnections between multiple sequencers for a good many more pages but it would prove little because there would always be still more pages to write. Anyway, you probably are beginning to see that the modules can be patched together however you like and the worst that can happen is nothing - there are no possible interconnections that will hurt anything. Some of the things that you might want to try are: Connecting one of the stage outputs of one sequencer to the RUN input of a second sequencer so that when the selected stage of the first sequencer goes high the second sequencer produces a rapid run.

Try interconnecting stage outputs between synchronized or non-synchronized sequencers to produce random - or pseudo-random sequences. When two stage outputs are tied together in this manner it produces the interesting effect of equivalency between the stage, anytime one of them goes high the other also goes high. Varying clock rates between units in this type of situation produces interesting results.

The control voltage output of the sequencer doesn't have to drive a VCO. It can also control the parameters of a filter.

Melodic lines aren't the only thing that a sequencer can generate. If you consider the module to be a versatile function generator a number of interesting uses come to mind such as the possibility of setting the pitch controls and glide controls such that the control voltage output is an approximation of the damped sinusoid shown in figure 6. When this type of waveform is capacitively coupled to one of the control voltage inputs of a VCO it produces an interesting decaying vibrato effect. Note that in this application the sequencer would be set up with R/S to "conditional run" and the manual controller's pulse output **LOADING** the counter. Change from the manual controller's pulse output to the step output and the counter won't load until the key is released - which means that when the note is first played there will be no vibrato but when the key is released, **B-O-I-N-G-I-N-G-I-N-G!**

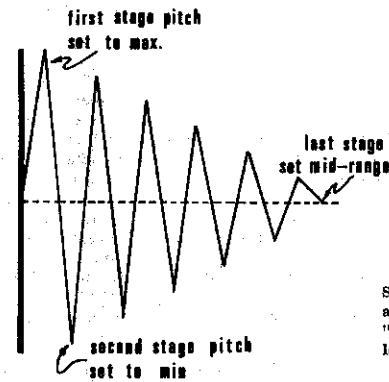

Sequencer generated approximation of a damped sinusoid, produced by setting "pitch" controls at alternating high and low settings.

Figure 6

DESIGN ANALYSIS

CLOCK

As is shown in the block diagram of the sequencer (figure 7) and the schematic (figure 8), the clock does a lot more than simply provide timing pulses for the ring counter.

At the heart of the clock is a simple relaxation oscillator built around a single Norton amplifier stage (pins 1, 5 & 6 of IC-1) which is arranged in a Schmitt trigger configuration. Assuming that the RUN/STOP switch is in the "run" position, there are three major bias sources to the inputs of this amplifier. The first is into the non-inverting input (pin 1) through resistor R18. The second is also applied to the non-inverting input and is derived from the normally high output of the amplifier through R16. The third current flows into the inverting input through R34 as a result of the voltage that appears across the timing capacitor C4.

During the major portion of a clock cycle, the combined current flow into the non-inverting input of the amplifier exceeds that which flows into the inverting input and as a result the output of the amplifier is held very close to the positive supply voltage.

As C4 charges through the fixed resistance R35 and the front panel rate control R135 the voltage across it eventually becomes such that the resulting current flow through R34 exceeds the combined current flow of R18 and R16 and at this point the output of the amplifier switches to a low state. Two things happen simultaneously. The current that was flowing through R16 is removed so that the current through R34 will have to decrease significantly before the amplifier can switch again and diode D1 becomes forward biased and begins to discharge C4.

As C4 discharges, its voltage soon reaches the point at which the current through R34 is less than that through R18 causing the amplifier's output to once again switch high. This simultaneously reverse biases D1 and re-establishes the feed-back current through R16. From this point the cycle repeats.

The minimum width of the negative going clock pulses that appear at pin 5 of IC-1 is limited by the dynamic impedance of diode D1 and while they are relatively short (about 1% of the total period at the slowest clock rate) they are far too long to use directly on the clock line. The clock pulses are differentiated by C1 and R15 and used to switch a second amplifier section of IC-1 (pins 10, 11, and 12). The output of this amplifier stage is once again high riding with micro-second range pulses to ground.

Switching the RUN/STOP switch to the "stop" position introduces a fourth bias current to the amplifier in the relaxation oscillator by raising the ungrounded side of R30 to the positive supply voltage. The resulting current flow through R31 and R19 is such that the total current flow into the non-inverting input of the amplifier is much greater than the current produced by the highest voltage that C4 can charge to. The output of the amplifier cannot switch to its low state and the clock can be considered off.

The fourth bias current can be removed and the clock started either by returning S1 to the "run" position or by turning on transistor Q2, thereby shorting the junction of R19 and R31 to ground. Q2 can be turned on and held on by applying a positive voltage to the "run" input jack on the front panel or it can be turned on for very short periods of time for synchronization purposes by applying pulses to the "synch" input pin jack. Pulses applied to the "synch" input are differentiated by capacitor C3 with the negative going spikes at the trailing edges of the pulses clamped to ground by D2.

To examine the operation of this comparator, assume that the relaxation oscillator is at the point where it is just ready to fire and produce a clock pulse. At this point the output of the comparator is low because there is greater current flow into pin 3 than pin 2. As soon as the output of the relaxation oscillator (pin 5) goes low the current that was flowing through R39 is removed. Without the current contribution of R39, there is greater current flow into the non-inverting input than the inverting input and the output of the comparator switches to its high state causing a voltage step to appear at the step trigger output.

The output of the relaxation oscillator quickly returns to its normal high state; but at the time that it does, the voltage appearing across C4 is considerably lower than it was at the point of firing. Even through the current flow through R39 is restored, there is still greater current flow into pin 2 of the comparator than pin 3 because of the reduced current flow through R39. As the voltage across C4 increases, the point is eventually reached at which the currents through R38 and R39 exceed that through R136 and the output of the comparator returns to its low state removing the voltage step

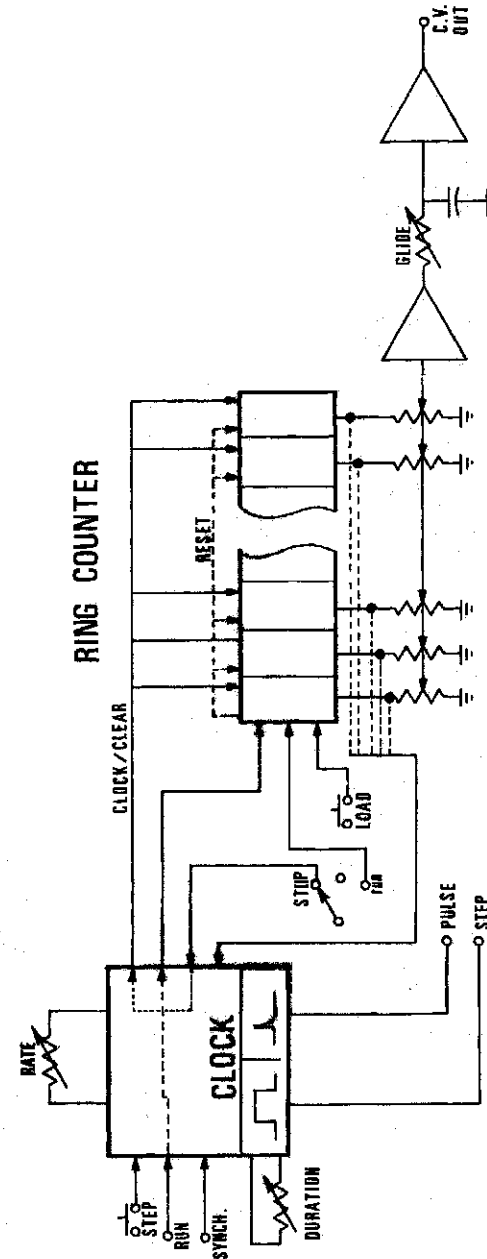

Figure 7

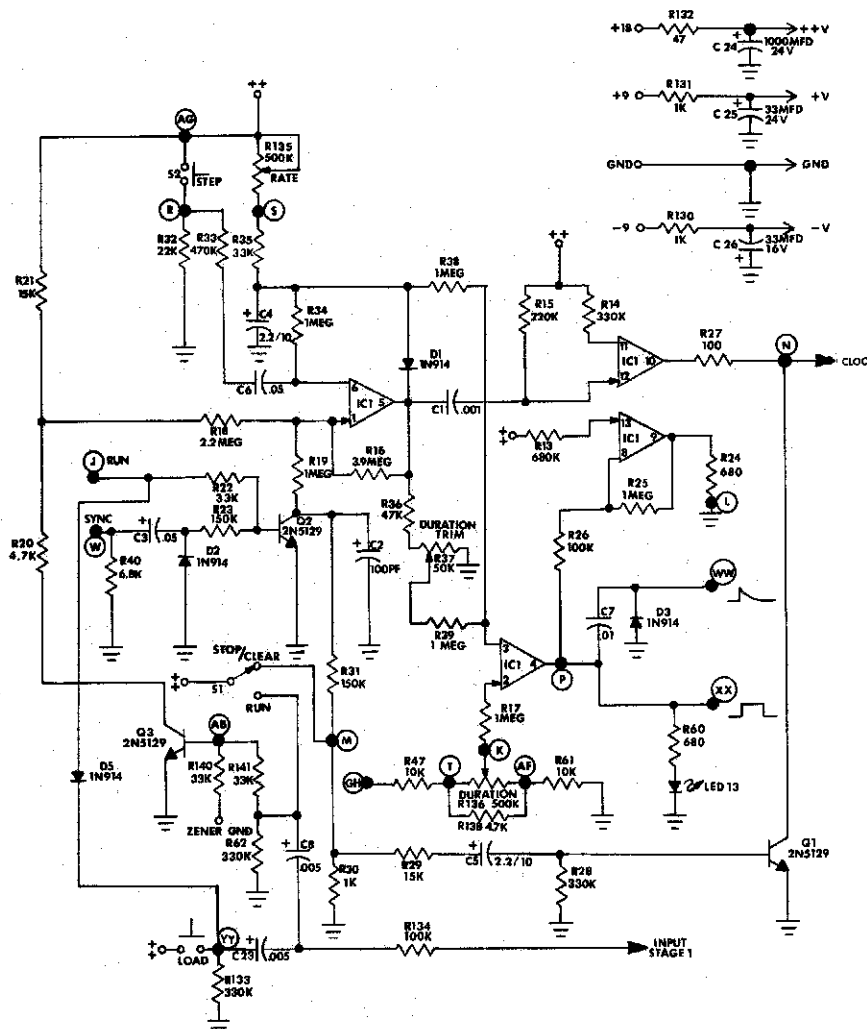

Figure 8

at the output. The point at which this transition to a low state occurs is a function of how high the voltage across C4 has to rise before the inverting input current exceeds the non-inverting input current and this in turn is dependent on the setting of the front panel DURATION control.

When the output of the comparator switches high, the leading edge of the step is differentiated to a pulse by C7 and appears at the front panel pulse trigger output jack. The negative spike that would appear at the trailing edge of the step is clamped to ground by D3.

The step trigger also directly drives the light emitting diode LED-13 which indicates to the user the duration of the step trigger output. In order to ease power supply regulation requirements, the relatively heavy periodic current flow required to light the LED is balanced by switching the dummy load R24 "on" anytime that the LED is off. The inversion required to perform this is provided by the fourth stage of the amplifier in the IC-1 package, pins 8, 9 and 13.

RING COUNTER

The design of the ring counter section of the sequencer is a common concept employing 12 serially coupled latches. A typical stage is shown below. Like any other latch, this circuit has two stable states. When the output voltage of the amplifier is low there is no current flow through the feedback resistor Rf and the greater current into the inverting input through Rb than through Rc into the non-inverting input causes the output to stay low.

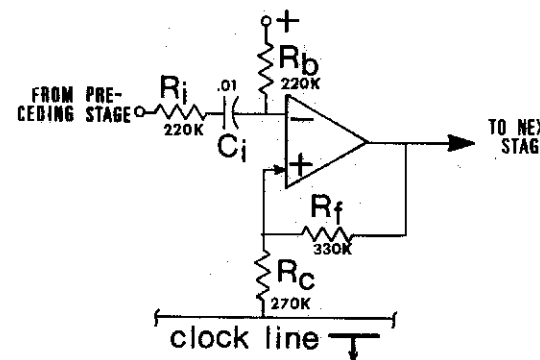

Once the circuit changes state to a high output a current begins to flow through Rf which when added to the current already flowing through Rc results in a greater total flow into the non-inverting input than is provided to the inverting input through Rb. The result is that the output stays high.

This stage can be "set" or "loaded" (output changed to a high state) by momentarily decreasing the current flow into the inverting input. This is the case when the series capacitance and resistance (Ri/Ci) are connected to the output of another latch whose output is transitioning from a high to a low state. Once set, the stage can be reset by momentarily dropping the clock line from positive supply to ground.

If the time constant of Ri/Ci is chosen such that it is long when compared to the duration of the clock pulse, a ring of these stages will count by advancing the high state from one stage to the next each time there is a clock pulse. In the process of being reset, each stage passes the count to the stage immediately following it in the chain.

The entire chain can be cleared by holding the clock line at ground for a period of time greater than the time constant of the Ri/Ci combination. When the RUN/STOP switch is set to the "stop/clear" position, the series combination of R29 and C5 on the clock board generate a relatively long (.5 sec. approximately) current pulse that turns on transistor Q1 which in turn shorts the clock line to ground.

It is undesirable to have more than a single stage of the counter set at any given time, yet this situation would naturally occur if the output of an intermediate stage of the counter was fed back into the input. To prevent this, the output of stage one serves as a reset for the rest of the stages.

When stage one goes high, current supplied to the inverting inputs of the rest of the stages in the counter by way of R111 - R121 causes each stage to reset.

The first stage of the counter can be set in a variety of ways. Pressing the front panel LOAD push button causes a voltage to appear across R133 on the clock board which is coupled to the non-inverting input of the first counter stage by means of C23 and R134. Applying a voltage step to the front panel RUN input jack produces an identical result because of diode D5 (but note that pressing the LOAD button reverse biases D5 and will not cause the clock to run). Setting the RUN/STOP switch to the "run" position causes a voltage to appear across R62 which when coupled through C8 and R134 produces the same results.

Taking the first as typical, the output of each of the counter stages is connected through a current limiting resistor (R7) to a light emitting diode (LED-1). All of the LEDs in turn connect to a common line that returns to ground through the zener diode D4. These LEDs and the zener perform a number of functions.

First, the LEDs light to indicate to the user which stage is currently loaded. Second, the LED and zener together serve to clamp the voltage that appears across the voltage divider at the output of each stage (R41 in stage 1) to a reference level of approximately 6 volts and thereby assists in eliminating voltage drift at the control voltage output of the sequencer. Third, the LEDs function as normal diodes to prevent interaction between the twelve counter stages. Finally, the voltage that appears across the zener any time that any of the ring counter stages are set serves as a signal back to the clock that the counter is loaded.

The multi-turn potentiometers at the output of each stage of the counter are resistance coupled (R1 in stage 1) to a common line that feeds non-inverting summing amplifier IC-5. The output of the summing amplifier is connected to the glide circuit consisting of the front panel GLIDE control R137 and capacitor C22. The emitter follower Q4 serves as an output buffer to minimize unwanted control voltage level changes that could otherwise be a side effect of changing the glide rate.

In the "conditional run" (middle) setting of the clock's RUN/STOP switch, the clock runs only when there is a "1" loaded into the ring counter (see USING section). This is accomplished by using the voltage that appears across the zener diode D4 when any stage of the counter is high (see ring counter analysis) to turn on transistor Q3 on the clock board. As long as Q3 is on, the voltage divider R21 and R20 in the clock is connected between positive supply and ground causing a normal bias current to flow through R18. When Q3 turns off, the voltage divider is no longer grounded causing the junction of R21 and R20 to rise to essentially supply thereby forcing 4 times more current to flow through R18 than previously. As explained previously, this stops the action of the relaxation oscillator. When the RUN/STOP switch is in the "run" position the current to hold Q3 on is supplied through R141.

A third amplifier in IC 1 (pins 2, 3 and 4) takes care of generating the step and pulse trigger outputs of the sequencer. This amplifier is wired as a comparator so that its output voltage (at pin 4) is low until the sum of the currents into the non-inverting input through R38 and R39 falls below the level of the reference current through R136.

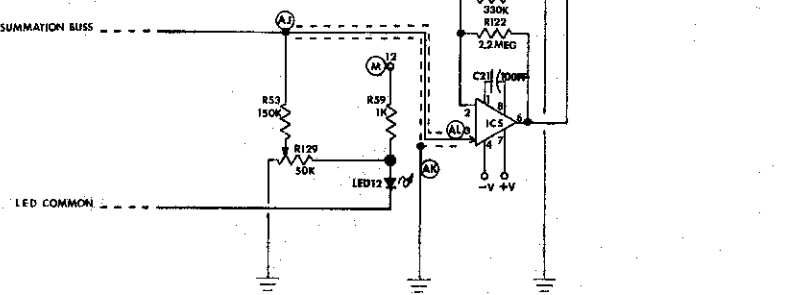
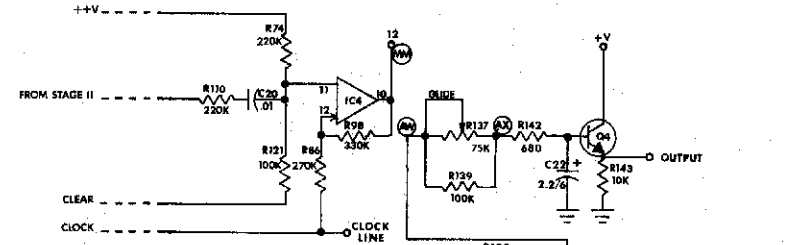
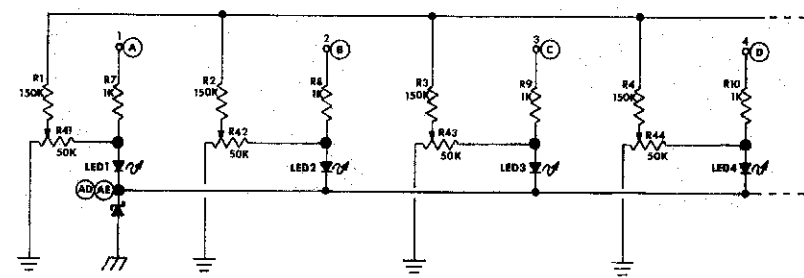
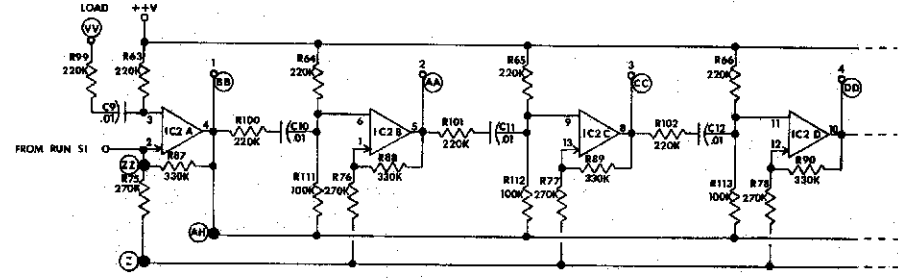

4-288D-85-5-676