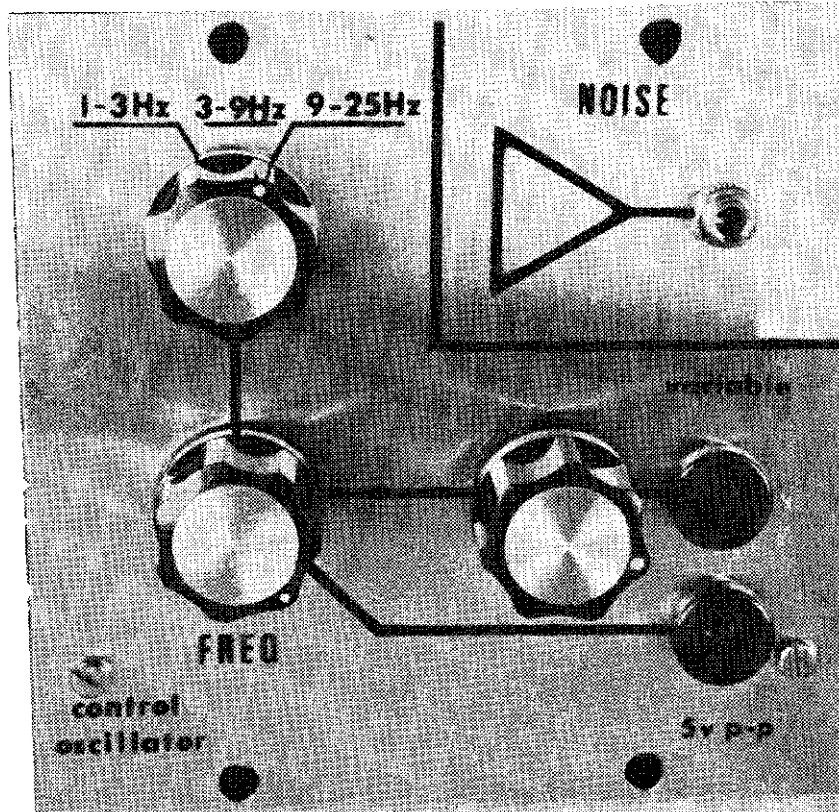

**2720-5****Control Oscillator/Noise Source**

The 2720-5 Control Oscillator / Noise Source is a dual function module providing a source of slowly varying sinusoidal control voltage for tremolo, vibrato, filter sweeping, etc. and a white noise source useful in a variety of special effects including wind and surf sounds.

**SPECIFICATIONS**

Module Power  
Requirements ..... 18v. @ 1.75ma.

**OSCILLATOR**

Output ..... Sinusoidal  
Output Impedance.... Nominal 5K or less  
Output Amplitude.... One fixed 5v. p-p output  
One variable 0 to 5v. p-p  
Output D.C. bias ... 50% of peak to peak value  
Frequency range .... 1 to 25 Hz in three overlapping  
ranges.

**NOISE SOURCE**

Output ..... Broadband noise  
nominal 100Hz to 10KHz  
Output Impedance .... Nominal 1K  
Output Amplitude..... .5v. p-p  
Output D.C. bias ..... None

## SOLDERING

Use care when mounting all components. Use only rosin core solder ( acid core solder is never used in electronics work.) A proper solder joint has just enough solder to cover the round soldering pad and about 1/16 inch of the lead passing through it. There are two improper connections to beware of: Using too little solder will sometimes result in a connection which appears to be soldered but actually there is a layer of flux insulating the component lead from the solder bead. This situation can be cured by re-heating the joint and applying more solder. If too much solder is used on a joint there is the danger that a conducting bridge of excess solder will flow between adjacent circuit board conductors forming a short circuit. Unintentional bridges can be cleaned off by holding the board up-side down and flowing the excess solder off onto a clean, hot soldering iron.

Select a soldering iron with a small tip and a power rating not more than 35 watts. Soldering guns are completely unacceptable for assembling transistorized equipment because the large magnetic field they generate can damage solid state components.

## CIRCUIT BOARD ASSEMBLY

- ( ) Prepare for assembly by thoroughly cleaning the conductor side of the board with a scouring cleanser. Rinse the board with clear water and dry completely.

Solder each of the fixed value resistors in place following the parts placement designators printed on the circuit board and the assembly drawing figure 1. Note that the fixed resistors are non-polarized and may be mounted with either of their two leads in either of the holes provided. Cinch the resistors in place prior to soldering by putting their leads through the holes and pushing them firmly against the board; on the conductor side of the board bend the leads outward to about a 45° angle. Clip off each lead flush with the solder joint as the joint is made.

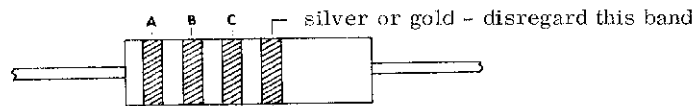

DESIGNATION	VALUE	COLOR CODE A-B-C
( ) R1	82K	grey-red-orange
( ) R2	3.9 megohm	orange-white-green
( ) R3	1000 ohm	brown-black-red
( ) R4	15K	brown-green-orange
( ) R5	15K	brown-green-orange
( ) R6	680 ohms	blue-grey-brown
( ) R8	1 megohm	brown-black-green
( ) R9	1 megohm	brown-black-green
( ) R10	100K	brown-black-yellow
( ) R11	4700 ohm	yellow-violet-red
( ) R12	150K	brown-green-yellow
( ) R13	27K	red-violet-orange
( ) R14	6800 ohm	blue-grey-red
( ) R15	2200 ohm	red-red-red
( ) R16	470 ohm	yellow-violet-brown
( ) R20	100 ohms	brown-black-brown

Install the ceramic disk and mylar capacitors. The ceramic disks without exception have their value marked on the body of the part but the mylar capacitors may be color coded as shown below:

DESIGNATION	VALUE	COLOR CODE A-B-C
( ) C1	.56 mfd. mylar	green-blue-yellow
( ) C2	.22 mfd. mylar	red-red-yellow
( ) C3	.1 mfd. mylar	brown-black-yellow
( ) C4	.56 mfd. mylar (see text)	
( ) C5	.22 mfd. mylar	"
( ) C6	.1 mfd. mylar	"
( ) C7	.56 mfd. mylar (see text)	
( ) C8	.22 mfd. mylar	"
( ) C9	.1 mfd. mylar	"
( ) C10	.05 mfd. ceramic disk	
( ) C11	.05 mfd. ceramic disk	
( ) C12	.05 mfd. ceramic disk	

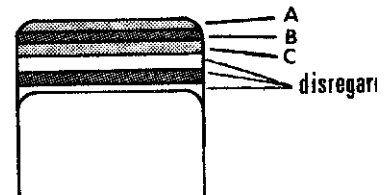

Up to this point all components have been non-polarized and either lead could be placed in either of the holes provided without affecting the operation of the unit. Electrolytic capacitors are polarized and must be mounted so that the "+" lead of the capacitor goes through the "+" hole in the circuit board. In the event that the "-" lead of the capacitor is marked rather than the "+" lead it is to go through the unmarked hole in the circuit board.

Note that the operating voltage (v.) specified for a capacitor is the minimum acceptable rating. Capacitors supplied with specific kits may have a higher voltage rating than that specified and may be used despite this difference. For instance, a 100 mfd. 25v. capacitor may be used in place of a 100 mfd. 16v. capacitor without affecting the operation of the circuit.

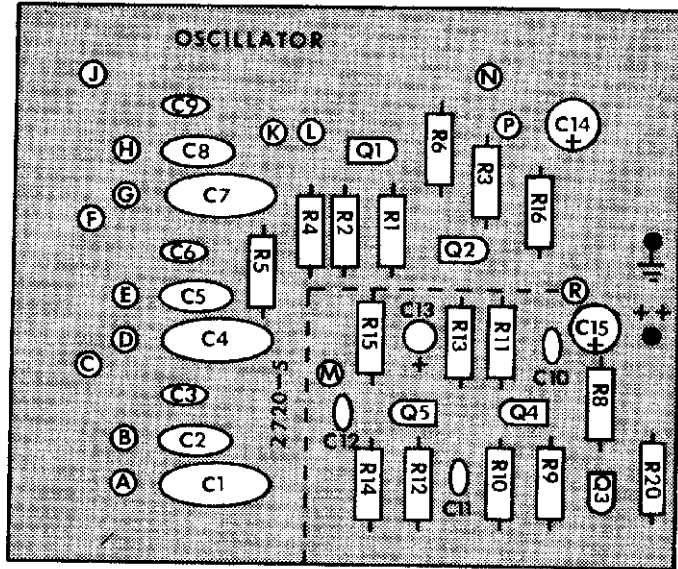

Figure 1

Mount the following electrolytic capacitors and solder them in place. The values, voltage rating and polarization are marked on the body of the part.

DESIGNATION	VALUE
( ) C13.....	30 mfd. 10v.
( ) C14.....	100 mfd. 16v.
( ) C15.....	1000 mfd. 16v.

Install the transistors. Orientation of the transistors is keyed by the roughly bullet shaped case and should be evident from inspection of the parts placement diagram shown in figure 1 and the parts placement designators printed on the circuit board. All semi-conductors are heat sensitive and may be damaged if allowed to get too hot during soldering. To be on the safe side heat sink each transistor lead during the soldering operation by grasping it with a pair of needle nose pliers at a point between the circuit board and the body of the transistor.

Note that the 2N3391 transistor is identified by white paint covering the top surface of the part.

DESIGNATION	VALUE
( ) Q1.....	2N3391
( ) Q2.....	2N2712
( ) Q4.....	2N2712
( ) Q5.....	2N2712

Note that the middle lead of one of the transistors is cut short. This transistor has been selected for its noise generating characteristics and is intended for use as Q3. Install this transistor as above.

( ) Q3.....	noise transistor
-------------	------------------

In the following steps wires will be soldered to the circuit board which will later connect to the front panel controls and jacks. At each step prepare the wire by cutting it to the specified length and stripping 1/4 inch of insulation from each end of the wire. "Tin" each end of the wire by twisting the exposed strands tightly together and melting a small amount of solder into the wire.

Using the wire provided make the following connections to the circuit board.

( ) a 6 1/4 inch length to point "A"	( ) a 4 1/4 inch length to point "J"
( ) a 6 1/4 inch length to point "B"	( ) a 2 3/4 inch length to point "K"
( ) a 6 1/4 inch length to point "C"	( ) a 2 3/4 inch length to point "L"
( ) a 5 1/4 inch length to point "D"	( ) a 5 inch length to point "M"
( ) a 5 1/4 inch length to point "E"	( ) a 6 1/4 inch length to point "N"
( ) a 5 1/4 inch length to point "F"	( ) a 6 1/4 inch length to point "P"
( ) a 4 1/4 inch length to point "G"	( ) a 7 inch length to point "R"
( ) a 4 1/4 inch length to point "H"	

THIS COMPLETES THE 2720-5 CIRCUIT BOARD ASSEMBLY. Temporarily put the circuit board aside and proceed to the mounting of front panel controls and jacks.

## FRONT PANEL ASSEMBLY

Place the front panel face down on a soft rag to prevent marring the finish.

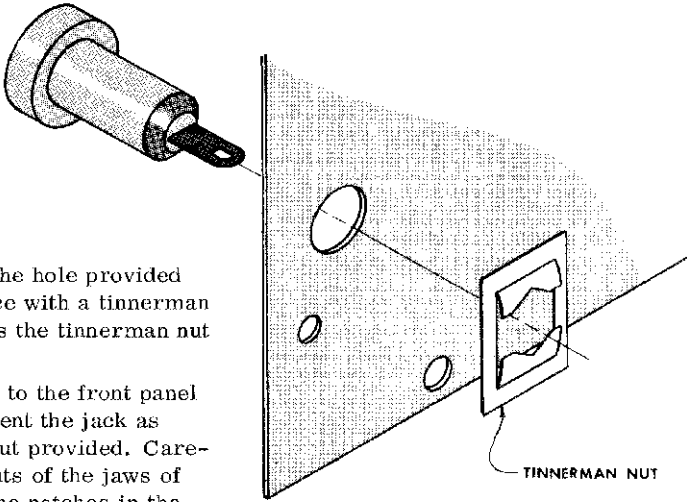
- ( ) Place a red pin jack (J2) in the hole provided as shown in figure 3 and fasten in place with a tinnerman nut as shown in detail figure 2. Press the tinnerman nut down firmly.
  - ( ) Place the second red pin jack (J3) in the hole provided as shown in figure 3 and fasten in place with a tinnerman nut as shown in detail figure 2. Press the tinnerman nut down firmly.
  - ( ) Mount the open circuit phone jack (J1) to the front panel in the position shown in figure 3. Orient the jack as shown and fasten it in place with the nut provided. Carefully tighten the nut by pulling the points of the jaws of a pair of small diagonal cutters into the notches in the nut using the cutters as a spanner.
- 
- Figure 2
- ( ) Mount rotary switch S1 in the position shown in figure 3. Note that a standard 3/8" nut is used as a spacer between the switch body and the back of the front panel (the threads of this nut will not mesh with the threads on the shaft of the switch) while the nut provided with S1 is used on the front of the panel to tighten the switch in place. Orient as illustrated.
  - ( ) Mount single section potentiometer R7 in the location shown in figure 3. Use two 3/8" nuts, one behind the front panel as a spacer and the second on the front side of the panel to secure the potentiometer. Adjust the rear nut so that none of the threaded shaft of the control is exposed when the front nut is tightened down. This will allow the control knob which will be mounted in a later step to seat as closely as possible to the panel. Orient as illustrated.
  - ( ) On a table orient dual section potentiometer R17 so that the solder lugs are pointing up and the shaft is pointing away from you.
  - ( ) Using the bare wire provided make a connection from the center lug on the section nearest you to the center lug on the section farthest away and then to the left hand lug of the far section and then to the left hand lug of the near section. This wire need not be wrapped around each of the terminals but needs only to pass through the holes in the center of the lugs. DO NOT CUT OFF THE WIRE COMING FROM THE LEFT HAND LUG OF THE NEAR SECTION. Solder the bare wire to the left hand lugs of both the near and far sections.
  - ( ) Mount resistor R18 ( 470K Yellow-violet-yellow ) between the center lug and the right hand lug of the far section of dual potentiometer R17. Solder the connection on the center lug only.
  - ( ) Mount resistor R19 ( 470K Yellow-violet-yellow ) between the center lug and the right hand lug of the near section of dual potentiometer R17. Solder the connection on the center lug only.
  - ( ) Mount dual section potentiometer R17 in the location shown in figure 3. Use two 3/8" nuts as on R7 and orient as shown.
  - ( ) Cut a 1 1/2" piece of tubing and slip it over the bare wire coming from R17.
  - ( ) Cut the wire coming from R17 so that 1/4" of wire is exposed from the tubing and connect this wire to the left hand lug of R7. DO NOT SOLDER.
  - ( ) Solder one end of a length of bare wire to the terminal on pin jack J2.
  - ( ) Cut a 1" piece of tubing and slip it over the wire coming from pin jack J2.
  - ( ) Cut the wire from the above steps so that 1/4" of wire is exposed from the end of the tubing and solder this lead to the center lug of R7.
  - ( ) Solder one end of a length of bare wire to the terminal on pin jack J3.
  - ( ) Cut a 1 3/4" piece of tubing and slip it over the wire coming from pin jack J3.
  - ( ) Cut the wire from the above steps so that 1/4" of wire is exposed from the tubing. Connect this wire to the right hand lug of R7. DO NOT SOLDER.

THE FRONT PANEL MAY NOW BE BOLTED TO THE CIRCUIT BOARD AS FOLLOWS:

- ( ) Fasten the two "L" brackets to the front panel using one 4-40 X 1/4" machine screw and one 4-40 nut on each bracket. Note that the unthreaded hole on the "L" bracket is used in this operation.

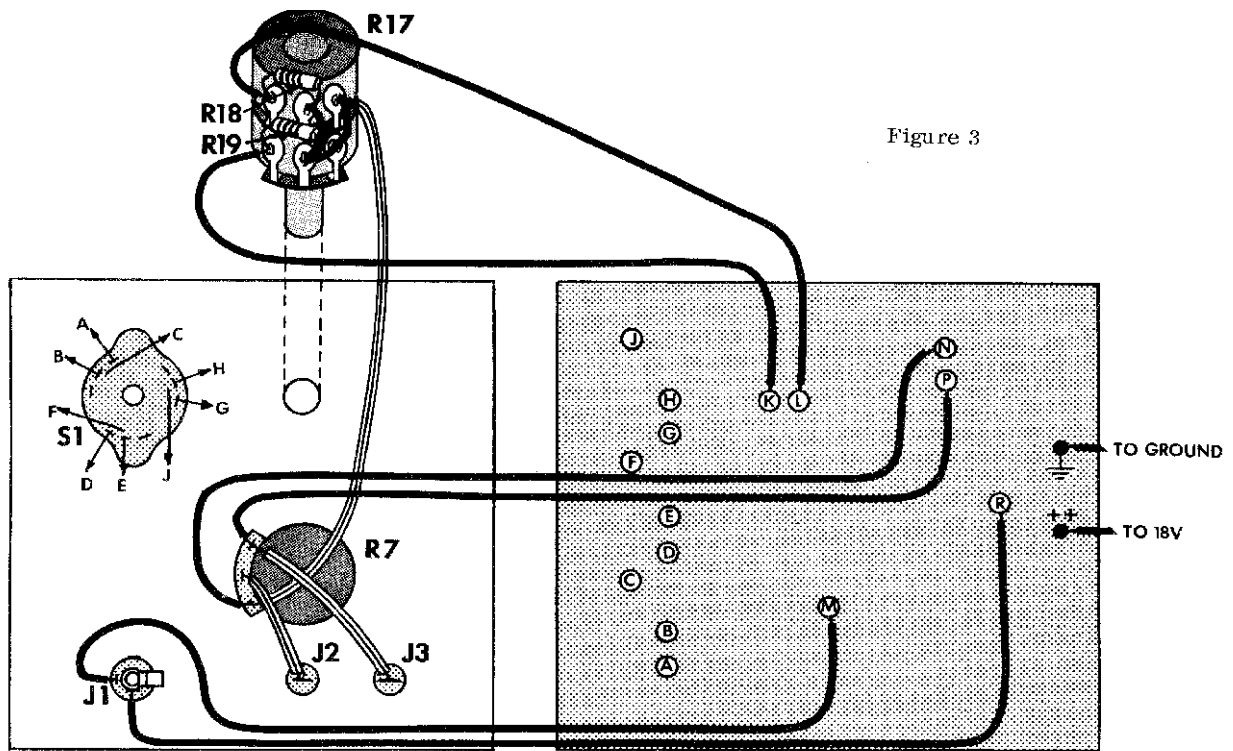

Figure 3

- ( ) Fasten the circuit board to the front panel "L" brackets by passing a 4-40 X 1/4" machine screw up through the holes in the circuit board and threading them into the threaded holes in the "L" brackets. Securely tighten all screws.

MAKE FINAL FRONT PANEL CONNECTIONS AS FOLLOWS: In these steps orientation of the panel is rear facing you with S1 & J1 up.

- ( ) Connect the wire coming from point "K" on the circuit board to the upper lug on the section of R17 closest to the front panel. Solder the two wires connected to this lug.
- ( ) Connect the wire coming from point "L" on the circuit board to the upper lug on the section of R17 farthest from the front panel. Solder the two wires connected to this lug.
- ( ) Connect the wire coming from point "N" on the circuit board to the left hand lug of R7. Solder two wires to this lug.
- ( ) Connect the wire from point "P" on the circuit board to the right hand lug of R7. Solder two wires to this lug.
- ( ) Solder the wire from point "R" on the circuit board to the left hand lug of phone jack J1.
- ( ) Solder the wire from point "M" on the circuit board to the center lug of phone jack J1.
- ( ) Solder the nine connections from circuit board points "A" through "J" to the rotary switch S1 as shown in assembly detail fig. 3. (Note that "I" is omitted.)
- ( ) Rotate all control shafts fully counter-clockwise as viewed from the front of the panel.
- ( ) Mount the coarse frequency adjust knob by placing it on the shaft of rotary switch S1, aligning the pointer with the 1-3Hz. marking and tighten the set screw.
- ( ) Mount the fine frequency adjust knob by placing it on the shaft of R17, aligning the pointer so that it points straight down and tighten the set screw.
- ( ) Mount the variable output attenuator knob by placing it on the shaft of R7, aligning the pointer so that it points straight down and tighten the set screw.

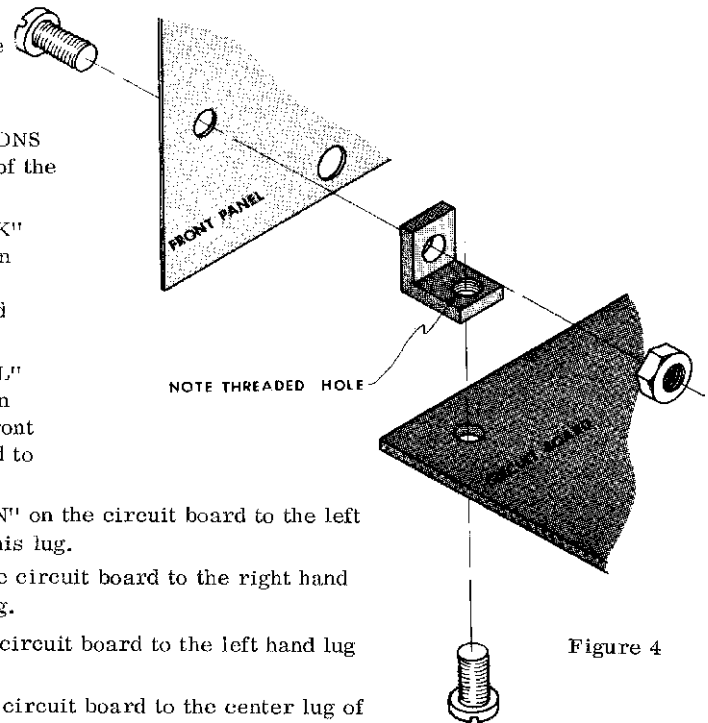

Figure 4

THIS COMPLETES ASSEMBLY OF THE CONTROL OSCILLATOR/ NOISE SOURCE MODULE.

## TESTING

Oscillator Apply an 18v. power supply (2720-7 power supply or other suitable supply such as two 9v. batteries) to the ++ and ground connections on the rear of the 2720-5 circuit board. The control oscillator is most easily tested using an oscilloscope but a volt-ohm meter can be used. If an oscilloscope is available connect its vertical input to the fixed 5v. p-p output of the oscillator and observe that the output is approximately 5 volts peak to peak. If the oscilloscope has a calibrated horizontal time scale check to make sure that the periods of oscillation agree with the table below at the control settings indicated.

S1	R17 (Freq.)	PERIOD
1 - 3	(c. c. w.) Min.	1 sec.
1 - 3	(c. w.) Max.	330 ms.
3 - 9	Min.	350 ms.
3 - 9	Max.	120 ms.
9 - 25	Min.	125 ms.
9 - 25	Max.	45 ms.

Due to component tolerances exact agreement is unlikely but observed periods should be within 20% of the above values. With this check completed connect the oscilloscope vertical input to the variable output J2 and observe that the attenuator R7 varies the output from 0v. to 5v. peak to peak. When observing the oscillator waveform on an oscilloscope you may note a slight flattening on the bottom of the sine wave. This flattening is normal and will not significantly affect the operation of the unit.

Operation of the oscillator can be roughly checked using only a volt-ohm meter as follows: Set the VOM to a range that will produce a 1/2 to full scale deflection for 5v. (e.g. a 10v. range) and connect the meter between the ground and fixed output with the positive lead to J3. Set frequency range switch S1 to the 1 - 3 Hz. range and rotate frequency control R17 fully counter-clockwise. Most meters will not accurately follow a 1 Hz. signal but you should be able to see the pointer swinging up and down and the extremes of the swing should center about the 2.5v. mark on the meter (for example between 1.5 and 3.5). Advance the freq. control and note that the rate of oscillation increases. As both the freq. range switch and freq. control are advanced the meter pointer should move less and less until at some point it stops at about 2.5v. (allow  $\pm 20\%$ ). Now change the positive meter lead to variable output J2 and observe that the attenuator varies the output level from 0v. to about 2.5v.

Noise Source The noise source is easily tested using either an audio amplifier or oscilloscope. If an oscilloscope is available connect the noise output jack J1 to the vertical input of the scope and observe that the peak to peak amplitude of the characteristically fuzzy noise signal is approximately 0.5v. The noise effect is best observed with a sweep rate of about 2 ms./cm. (repetition rate of about 50/second on oscilloscopes without a calibrated time base). If an amplifier is handy the output of the noise source can be jumpered directly to the high level input of the amplifier. Test for an even coloration of the noise by alternately advancing and retarding the bass and treble tone controls of the amplifier. During this test the character of the noise should change noticeably (this will of course depend on the characteristics of the amplifier's tone control).

### USING THE 2720-5 CONTROL OSCILLATOR/NOISE SOURCE MODULE

The decision to make the Noise Source and Control Oscillator one module was based on many considerations involving cost, size, versatility, etc. Neither the control oscillator nor the noise source are items that are likely to be duplicated within any single system yet one of each is highly desirable. Also, the number of knobs required by the control oscillator dictates a double module (4" X 4") size while the electronics could easily fit on a single module circuit board.

### OPERATION OF THE CONTROLS IS AS FOLLOWS:

COARSE FREQUENCY The coarse frequency adjust is the control in the upper left hand corner of the module panel. Three overlapping frequency ranges allow the oscillator to generate any frequency in the 1 to 25 Hz. range.

FREQ. The freq. control allows the selection of any particular frequency within the range selected by the Coarse Frequency control.

VARIABLE OUTPUT The output jack marked "variable" provides an output voltage that is continuously variable between 0 and 5v. peak to peak, adjustable by means of the control immediately to the left of the jack.

5v. p-p This output jack provides a non-adjustable source of control voltage that is always 5v. peak to peak at the rate set by the frequency controls.

NOISE The noise output jack provides capacitively coupled source of .5v. peak to peak broad-band noise.

The two most obvious uses for the control oscillator are producing tremolo and vibrato. Tremolo is a rapid amplitude modulation of a musical waveform and this effect is produced by using the oscillator output as one of the inputs to the Voltage Controlled Amplifier (VCA). The sinusoidal output of the oscillator alternately increases and decreases the gain of the VCA and consequently the amplitude of the output waveform. Vibrato is a rapid change in the pitch of a musical note and is produced by using the oscillator as one of the inputs to the Voltage Controlled Oscillator (VCO).

Another possible use for the Control Oscillator is as a "sweeping" signal for a Voltage Controlled Filter (VCF). Once again the output of the Control Oscillator is used as one of the control inputs of the filter and as the oscillator output makes its cyclic change it changes the characteristics of the filter. Typical of the effects produced in this manner would be an automatic "Waa-Waa" if the oscillator were driving the band-pass filter.

The Control Oscillator is not limited to driving a VCO, VCA or VCF; the output is short circuit protected and cannot be damaged short of plugging it directly into a 110v. wall outlet. For instance, while it is not immediately obvious, the Control Oscillator can serve as a trigger source for the 2720-4 function generator. By jumpering the variable output of the Control Oscillator into the "trigger" jack on the function generator it is possible to produce repeating waveforms with a variety of off time, rise time, fall time and sustain time characteristics.

At some point on the output sinusoid of the Control Oscillator - the exact point is controllable using the control oscillator output attenuator - the function generator will trigger and generate an output waveform whose attack and decay times are independently variable. Repetition rate of the function generator output is adjustable with the frequency controls of the control oscillator.

Noise is a very difficult thing to describe in other than technical terms but for our purposes we will define it as unvoiced sound, unvoiced in that it has no definite pitch or timbre like voiced sounds such as sine or square waves do. At first thought it might seem that there wouldn't be much you could do with an unvoiced sound when in fact it is one of the most versatile building blocks in the electronic musician's bag of tricks. For instance the sound of a cymbal is synthesized using noise. Run the noise output into a band-pass filter set to a high "Q" and a high frequency (see 2720-3b Band-pass Filter Instructions) and run the output of the filter into the audio input of a VCA which is in turn under the control of the function generator set to give a rapid attack and moderate decay. Every time the manual trigger is pressed out comes a cymbal sound.

The sound of the surf is easy to duplicate using noise. Run the output of the noise source into the input of a Voltage controlled low pass filter and the output of the filter into the audio input of a VCA, Control both VCF and VCA from the same output of the function generator set for long attack and decay and when the manual trigger is pressed out comes an ocean wave. For this effect it will also be necessary to "bias" the VCF and VCA slightly as explained in the 2720 Power Supply instructions.

The sound of the wind can be synthesized by running noise through a VCA and band pass filter. If one of the bias controls on the power supply is used as the control voltage source for both modules the wind can be made to whistle by randomly turning this control up and down. If a linear controller is used as the control voltage source for the VCF the wind can be played like a musical instrument.

#### DESIGN ANALYSIS

Control Oscillator The control oscillator circuit is a common phase shift type with transistor Q1 providing gain and  $180^\circ$  of phase shift while the remaining  $180^\circ$  of required phase shift is provided by the pi network C1 - C9 and R4, R5 and R17 - R19. Emitter follower buffer Q2 isolates the load from the oscillator stage.

The only thing unusual about the design of the oscillator is the switching of capacitors C1-C9. Referring to schematic diagram figure 5 you can see that in the 1-3Hz. position of S1, C1 is in parallel with C3, C4 with C6 and C7 with C9. In this position the total capacitance in each branch of the pi network is .66 mfd. In the 3-9 Hz. position the series combination of C1 and C2 is in parallel with C3, C4 and C5 in parallel with C6, C7 and C8 in parallel with C9. This arrangement gives a total capacitance of approximately .2 mfd. In the 9 - 25 Hz position C3, C6 and C9 are the only capacitors in the circuit for a total capacitance in each branch of .1 mfd.

Noise Source As can be seen from the schematic diagram figure 5 the noise source is a very simple circuit. Transistor Q3 is a silicon type that has a low emitter to base breakdown voltage rating. The 18v. power supply is more than enough to cause this base-emitter junction to operate in an avalanche condition.

Resistor R8 in the base circuit of Q3 limits the current flow through the junction and also serves as a load resistor for the shot noise that results from the avalanche process. The random ac voltage fluctuations produced by the avalanche are coupled into a single common emitter amplifier stage (Q4) through capacitor C11. This first stage not only boosts the signal slightly but also serves as an impedance matching element between the noise source and the main amplifier Q5. The amplified noise is coupled by C12 to the front panel output jack.

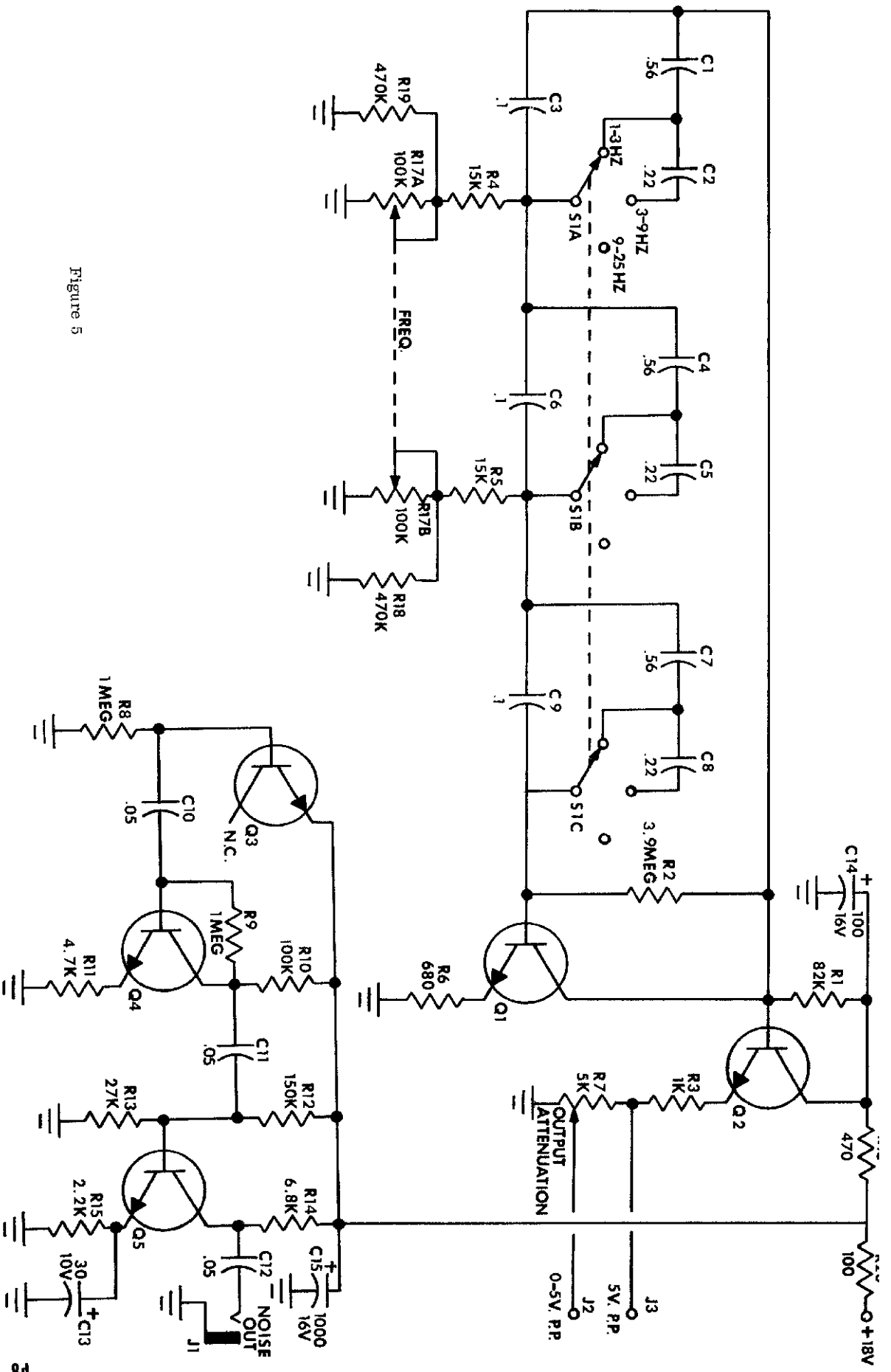

Figure 5