

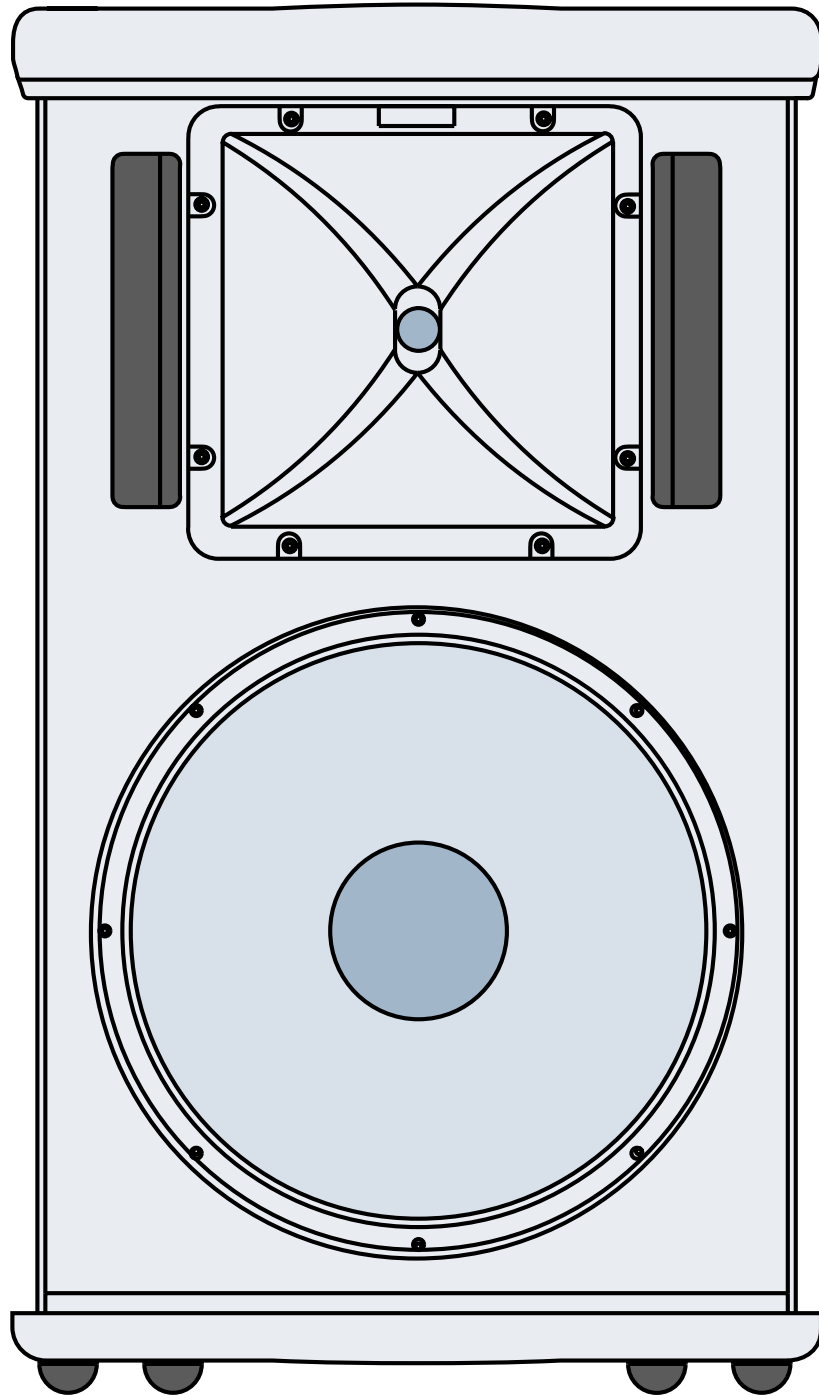

[®]**MACKE**

**SA1521
2-WAY ACTIVE
SPEAKER SYSTEM
USER'S MANUAL**



 <div style="background-color: black; color: white; padding: 5px; font-weight: bold; font-size: 1.2em;">CAUTION AVIS</div> <div style="text-align: center; font-weight: bold; font-size: 0.8em;">RISK OF ELECTRIC SHOCK DO NOT OPEN RISQUE DE CHOC ELECTRIQUE NE PAS OUVRIR</div> 
<p>CAUTION: TO REDUCE THE RISK OF ELECTRIC SHOCK DO NOT REMOVE COVER (OR BACK) NO USER-SERVICEABLE PARTS INSIDE REFER SERVICING TO QUALIFIED PERSONNEL</p> <p>ATTENTION: POUR EVITER LES RISQUES DE CHOC ELECTRIQUE, NE PAS ENLEVER LE COUVERCLE. AUCUN ENTRETIEN DE PIECES INTERIEURES PAR L'USAGER. CONFIER L'ENTRETIEN AU PERSONNEL QUALIFIE.</p> <p>AVIS: POUR EVITER LES RISQUES D'INCENDIE OU D'ELECTROCUTION, N'EXPOSEZ PAS CET ARTICLE A LA PLUIE OU A L'HUMIDITE</p>



The lightning flash with arrowhead symbol within an equilateral triangle is intended to alert the user to the presence of uninsulated "dangerous voltage" within the product's enclosure that may be of sufficient magnitude to constitute a risk of electric shock to persons.

Le symbole éclair avec point de flèche à l'intérieur d'un triangle équilatéral est utilisé pour alerter l'utilisateur de la présence à l'intérieur du coffret de "voltage dangereux" non isolé d'ampleur suffisante pour constituer un risque d'électrocution.



The exclamation point within an equilateral triangle is intended to alert the user of the presence of important operating and maintenance (servicing) instructions in the literature accompanying the appliance.

Le point d'exclamation à l'intérieur d'un triangle équilatéral est employé pour alerter les utilisateurs de la présence d'instructions importantes pour le fonctionnement et l'entretien (service) dans le livret d'instruction accompagnant l'appareil.

SAFETY INSTRUCTIONS

1. Read Instructions — All the safety and operation instructions should be read before this Mackie product is operated.
2. Retain Instructions — The safety and operating instructions should be kept for future reference.
3. Heed Warnings — All warnings on this Mackie product and in these operating instructions should be followed.
4. Follow Instructions — All operating and other instructions should be followed.
5. Water and Moisture — This Mackie product should not be used near water — for example, near a bathtub, washbowl, kitchen sink, laundry tub, in a wet basement, near a swimming pool, swamp, or salivating St. Bernard dog, etc.
6. Cleaning — Clean only with a dry cloth.
7. Ventilation — This Mackie product should be situated so that its location or position does not interfere with its proper ventilation. For example, the Component should not be situated on a bed, sofa, rug, or similar surface that may block any ventilation openings, or placed in a built-in installation such as a bookcase or cabinet that may impede the flow of air through ventilation openings.
8. Heat — This Mackie product should be situated away from heat sources such as radiators or other devices which produce heat.

WARNING: The heatsink may reach high temperatures during standard use. To ensure proper operation, allow a minimum of 6 inches of clearance from the heatsink surface and adequate ventilation.

PORTABLE CART WARNING



Carts and stands - The Component should be used only with a cart or stand that is recommended by the manufacturer. A Component and cart combination should be moved with care. Quick stops, excessive force, and uneven surfaces may cause the Component and cart combination to overturn.

9. Power Sources — This Mackie product should be connected to a power supply only of the type described in these operation instructions or as marked on this Mackie product.

10. Power Cord Protection — Power supply cords should be routed so that they are not likely to be walked upon or pinched by items placed upon or against them, paying particular attention to cords at plugs, convenience receptacles, and the point where they exit this Mackie product.

11. Object and Liquid Entry — Care should be taken so that objects do not fall into and liquids are not spilled into this Mackie product.

12. Damage Requiring Service — This Mackie product should be serviced only by qualified service personnel when:

- A. The power-supply cord or the plug has been damaged; or
- B. Objects have fallen, or liquid has spilled into this Mackie product; or
- C. This Mackie product has been exposed to rain; or
- D. This Mackie product does not appear to operate normally or exhibits a marked change in performance; or
- E. This Mackie product has been dropped, or its chassis damaged.

13. Servicing — The user should not attempt to service this Mackie product beyond those means described in this operating manual. All other servicing should be referred to the Mackie Service Department.

14. To prevent electric shock, do not use this polarized plug with an extension cord, receptacle, or other outlet unless the blades can be fully inserted to prevent blade exposure.

Pour prévenir les chocs électriques ne pas utiliser cette fiche polarisée avec un prolongateur, un prise de courant ou une autre sortie de courant, sauf si les lames peuvent être insérées à fond sans laisser aucune partie à découvert.

15. Grounding or Polarization — Precautions should be taken so that the grounding or polarization means of this Mackie product is not defeated.

16. Power Precaution — Unplug this Mackie product during lightning storms or when unused for long periods of time. Note that this Mackie product is not completely disconnected from the AC mains when the power switch is in the OFF position.

17. This apparatus does not exceed the Class A/Class B (whichever is applicable) limits for radio noise emissions from digital apparatus as set out in the radio interference regulations of the Canadian Department of Communications.

ATTENTION — *Le présent appareil numérique n'émet pas de bruits radioélectriques dépassant les limites applicables aux appareils numériques de class A/de class B (selon le cas) prescrites dans le règlement sur le brouillage radioélectrique édicté par les ministere des communications du Canada.*

WARNING — To reduce the risk of fire or electric shock, do not expose this appliance to rain or moisture.

WARNING — The cabinet has no rigging points and is not suitable for flying. Never attempt to suspend the cabinet by its handles.

Lend Me Your Ears



Exposure to extremely high noise levels may cause permanent hearing loss. Individuals vary considerably in susceptibility to noise-induced hearing loss, but nearly everyone will lose some hearing if exposed to sufficiently intense noise for a period of time. The U.S. Government's Occupational Safety and Health Administration (OSHA) has specified the permissible noise level exposures shown in this chart.

According to OSHA, any exposure in excess of these permissible limits could result in some hearing loss. To ensure against potentially dangerous exposure to high sound-pressure levels, it is recommended that all persons exposed to equipment capable of producing these levels use hearing protectors while this unit is in operation. Ear plugs or protectors in the ear canals or over the ears must be worn when operating this amplification system in order to prevent a permanent hearing loss if exposure is in excess of the limits set forth here.

Duration Per Day In Hours	Sound Level dBA, Slow Response	Typical Example
8	90	Duo in small club
6	92	
4	95	Subway Train
3	97	
2	100	Very loud classical music
1.5	102	
1	105	Tami screaming at Adrian about deadlines
0.5	110	
0.25 or less	115	Loudest parts at a rock concert



The SA1521 can produce a maximum SPL of 133 dB @ 1m

Contents

SAFETY INSTRUCTIONS	2
INTRODUCTION	4
REAR PANEL DESCRIPTION	4
HOOKUP DIAGRAM	5
CONNECTIONS	5
PLACEMENT	6
AC POWER	6
THERMAL CONSIDERATIONS	6
SERVICE INFORMATION	7
Warranty Service	7
Troubleshooting	7
Repair	8
CARE AND MAINTENANCE	8
SA1521 SPECIFICATIONS	9
Architects and Engineers' Specifications	10
FREQUENCY RESPONSE GRAPH	10
SA1521 LIMITED WARRANTY	11

Don't forget to visit our website at www.mackie.com
for more information about this and other Mackie products.



INTRODUCTION

Thank you for choosing a Mackie active sound reinforcement speaker system.

The SA1521 is a high-efficiency, extreme output, active two-way, wide dispersion, sound reinforcement speaker system. The SA1521 benefits from the integration of 500 watts of amplifier power, complete active control electronics, and RCF Precision components. These elements together form a speaker system with 100 dB of sensitivity (@ 1 watt/1 meter). The result is unprecedented output, resolution and clarity.

The components inside the SA1521 incorporate several state of the art advancements in transducer technology. These advancements have been in development for over two years. The compression driver is a new 1.75-inch titanium diaphragm design. It features a 3-slot, low-distortion geometry phase plug. The amplifier for the compression driver incorporates a Class AB topology renowned for its clarity and warmth.

The low-frequency amplifier features an innovative Class G hybrid topology. By incorporating a high-frequency switcher into the amplifier power supply design and focusing the design effort into generating the best possible “application-specific” amplifier design, we arrived at a high-efficiency amplifier that delivers 400 watts RMS (continuous), and 600 watts peak at 100 Hz. It’s quite capable of dealing with

the high phase shift characteristics of large diameter woofers.

More importantly, the amplifier incorporates the high-voltage output required to generate extreme SPL levels. The SA1521 also features a low-distortion, high-output horn design. This was developed to provide the correct power response and phase

alignment characteristics at the crossover frequency. Ultra-wide, controlled dispersion performance continues to be one of Mackie Designs’ most important engineering goals for sound reinforcement enclosures. With the resulting 75° x 65° dispersion pattern, the SA1521 provides very open, natural sound reproduction at extreme output levels.

The rear mounted amplifier assembly features separate signal and AC power panels separated by

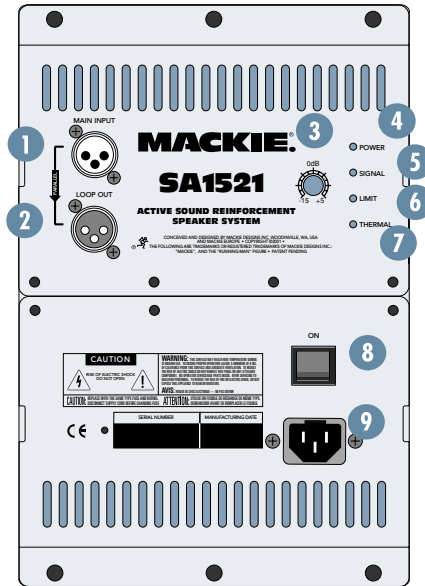

a large aluminum heatsink. The signal input panel contains:

- an input XLR and loop through XLR
- a volume level control
- Power On indicator
- Signal Present indicator
- Limit indicator
- Thermal protection indicator

The system accepts a standard line-level signal via an XLR input connector.

The SA1521 cabinet is constructed using both multi-layered plywood and pressure-injected structural resin caps. The top and bottom sections both have handles for easy movement and relocation.

REAR PANEL DESCRIPTION

1 MAIN INPUT

This is a female XLR-type connector that accepts a balanced line-level signal from a mixing console or other signal source.

2 LOOP OUT

This is a male XLR-type connector that produces exactly the same signal that is connected to the MAIN INPUT jack. Use it to daisy-chain several SA1521s together off the same signal source.

3 Level Control

This controls the overall signal level at the input to the built-in power amplifiers. This control ranges from -15 dB to +5 dB of gain. The center detent is 0 dB (unity gain).

4 Power ON Indicator

When the power switch is turned on, and the linecord is connected to an active AC power supply, this indicator lights green to let you know that you’re ready to rock and roll. The cool blue LED on the front of the cabinet works in the same way.

5 SIGNAL Present Indicator

This LED illuminates whenever there is a signal present at the MAIN INPUT connector on the rear panel. It senses the signal just after the Level control, so if the Level control is turned down, the SIGNAL Present indicator turns off.

6 LIMIT Indicator

The SA1521 has a built-in limiter that prevents the amplifier outputs from clipping or overdriving the transducers. The LIMIT indicator lights when the limiter is activated. It's okay for the LIMIT indicator to blink occasionally, but if it blinks frequently or lights continuously, turn down the level control until the LIMIT indicator only blinks occasionally.

7 THERMAL Indicator

There is also a thermal protection circuit that monitors the internal temperature of

the amplifiers and heatsink. If the temperature should exceed a safe operating level, this indicator lights and the signal is muted to allow the amplifiers to cool. When the temperature cools to a safe level once again, the thermal protection circuit deactivates and normal operation continues.

Note: Activation of the thermal protection circuit is an indication that you should take steps to avoid continued thermal problems. See "Thermal Considerations" on page 6.

8 Power Switch

Use this switch to turn the SA1521 on and off. Make sure the level control is turned down before you turn it on.

9 AC Receptacle

This is where you connect the AC linecord to provide AC power for the built-in power amplifiers. Plug the linecord into an AC socket properly configured for your particular model.

HOOKUP DIAGRAM

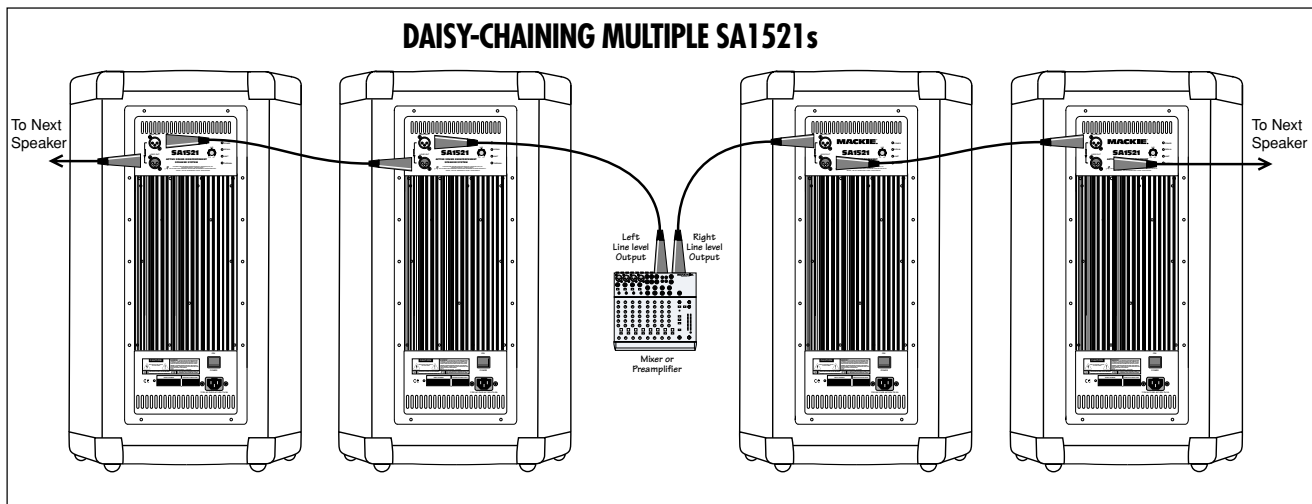

CONNECTIONS

The SA1521 has one female XLR input that accepts a balanced line-level signal. When connecting a balanced signal, be sure it's wired per AES (Audio Engineering Society) standards:

	<u>XLR</u>
Hot (+)	Pin 2
Cold (-)	Pin 3
Shield (Ground)	Pin 1

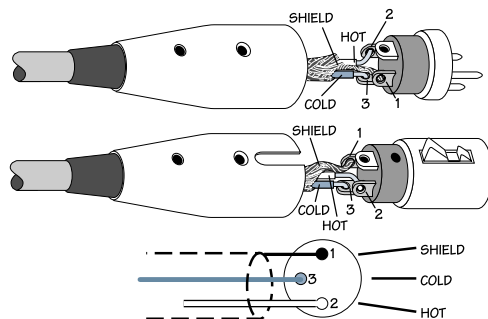

Balanced XLR Connectors

There is also a male XLR connector labeled LOOP OUT. This is also wired according to the AES standard.

The LOOP OUT connector allows you to connect more than one SA1521 to your system. Simply plug the signal source (i.e., mixer output) into the first MAIN INPUT jack, and patch that speaker's LOOP OUT jack to the next MAIN INPUT jack, and so on, daisy-chaining multiple speakers.

The LOOP OUT jack is wired straight from the MAIN INPUT connector — there is no electronic circuitry between — so the signal coming out of the LOOP OUT jack is exactly the same as the signal going in.

PLACEMENT

The SA1521 speaker is designed to sit on the floor or stage. It can be pole-mounted via the built-in socket on the bottom of the cabinet. Be sure the pole is capable of supporting the 100 lbs. weight of the SA1521.



WARNING: The cabinet has no rigging points and is not suitable for flying. **NEVER** attempt to suspend the SA1521 by its handles.

You can create a horizontal array by placing the cabinets side-by-side. However, you should have a good understanding of the relationship between the splay angle (the angle between the facing sides of the cabinets), the on-axis power, and frequency cancellation effects between cabinets.

When two cabinets are placed side-by-side, the actual splay angle is 20° (determined by a 10° angle on each cabinet side). As the splay angle increases toward the angle of horizontal coverage (75° for the SA1521), the on-axis power decreases, but the frequency response becomes smoother as the comb-filtering effects (caused by the interaction in the area of double-coverage) decrease.



As with any powered components, protect them from moisture. If you are setting them up outdoors, make sure they are under cover if you expect rain.

AC POWER

Be sure the SA1521 is plugged into an outlet that is able to supply the correct volt-

age specified for your model. If the voltage should drop below 97 % of the specified line voltage, the built-in amplifiers will no longer be able to supply rated power. (They will continue to operate down to 80 % of the rated line voltage, but won't reach full power, resulting in lower headroom.)

Be sure the electrical service can supply enough amperage for all the components connected to it.

We recommend that a stiff (robust) supply of AC power be used because the amplifiers place high current demands on the AC line. The more power that is available on the line, the louder the speakers will play and the more peak output power will be available for cleaner, punchier bass. A suspected problem of "poor bass performance" is often caused by a weak AC supply to the amplifiers.

CAUTION: Never remove the ground pin on the power cord of the SA1521 or any other component. This is very dangerous.

THERMAL CONSIDERATIONS

The SA1521 has two powerful built-in amplifiers capable of producing a combined 500 watts of power. As amplifiers produce heat, it is important to dissipate the heat as quickly as possible. This results in increased reliability and longevity for the amplifier.

The amplifier module is mounted on a large heatsink, which is cooled by convection where cool air is drawn through its fins, carrying the heat away. In order for this convection cooling to work efficiently, it is important to provide adequate airspace behind the loudspeaker. When you position the SA1521, we recommend leaving at least six inches of air space behind it.

In the unlikely event of the amplifier overheating, a built-in thermal switch will activate, which mutes the signal and lights the THERMAL LED. When the amplifier has cooled down to a safe operating temperature, the thermal switch resets itself, and the SA1521 resumes normal operation.

If the thermal switch activates frequently, try turning down the level control a notch or two on the mixing console (or the back of the SA1521) to avoid overheating the amplifier.

If the temperature in the room is too high, it could cause the amplifier to overheat. In this case, you should try aiming a fan at the rear panel to move more air through the fins.

SERVICE INFORMATION

Warranty Service

If you think your loudspeaker has a problem, please do everything you can to confirm it before calling for service, including reading through the following Troubleshooting section. Doing so might save you from being deprived of your Mackie loudspeaker.

Of all Mackie products returned for service (which is hardly any at all), many are coded “CND” — Could Not Duplicate—which usually means the problem lay somewhere else in the system. The following troubleshooting tips may sound obvious, but here are some things you can check:

Troubleshooting

No power

- Our favorite question: Is it plugged in? Make sure the AC outlet is live (check with a tester or lamp).
- Our next favorite question: Is the POWER switch on? If not, try turning it on.
- Is the POWER LED on the rear panel glowing green? If not, make sure the AC outlet is live. If so, refer to “No sound” below.
- The internal AC line fuse may be blown. This is not a user serviceable part. If you suspect the AC line fuse is blown, please see the REPAIR section next.

No sound

- Is the input LEVEL control for the input source turned all the way down? Verify that all the volume controls in the system are properly adjusted.
- Is the signal source working (and making union scale)? Make sure the connecting cables are in good repair and securely connected at both ends. Make sure the output volume (gain) control on the mixing console is turned up sufficiently to drive the inputs of the speaker.
- Make sure the mixer does not have a Mute on or a Processor loop engaged. If you find something like this, make sure the volume/gain is turned down before disengaging the offending switch.

- Is the THERMAL indicator lit red on the rear panel? Make sure there is at least six inches of free space behind the SA1521.

Poor bass performance

- Check the polarity of the connections between the mixer and the loudspeakers. You may have your positive and negative connections reversed at one end of one cable, causing one loudspeaker to be out-of-phase.

Poor sound

- Is it loud and distorted? Make sure that you’re not overdriving a stage in the signal chain. Verify that all level controls are set properly.
- Is the input connector plugged completely into the jack? Be sure all connections are secure. It’s a good idea to periodically clean all electrical connections with a non-lubricating electrical contact cleaner.

Noise

- Make sure all connections to the active loudspeakers are good and sound.
- Make sure none of the signal cables are routed near AC cables, power transformers, or other EMI-inducing devices.
- Is there a light dimmer or other SCR-based device on the same AC circuit as the SA1521? Use an AC line filter or plug the SA1521 into a different AC circuit.

Hum

- Try disconnecting the cable connected to the MAIN INPUT jack. If the noise disappears, it could be a “ground loop,” rather than a problem with the SA1521. Try some of the following troubleshooting ideas:
- Use balanced connections throughout your system for the best noise rejection.
- Whenever possible, plug all the audio equipment’s linecords into outlets which share a common ground. The distance between the outlets and the common ground should be as short as possible.

Repair

Service for the SA1521 is available only from one of our authorized domestic service stations or at the factory service center located in Whitinsville, Massachusetts. Service outside the United States can be obtained through local dealers or distributors.

If your SA1521 needs service, please follow these instructions:

1. Review the preceding troubleshooting suggestions. Please.
2. Call Mackie Tech Support at 1-800-898-3211, 7 AM to 5 PM PST, to explain the problem in detail. They will ask you all sorts of impertinent questions in the hope of sorting out the problem. If it appears that the SA1521 needs repair, request an RA (Return Authorization) number. Have your loudspeaker's serial number ready. You must have an RA number before you can obtain service at the factory or an authorized service center.
3. Keep this user's manual and the detachable linecord. We don't need them to repair the loudspeaker.
4. Pack the loudspeaker in its original packaging, including protective wrap, endcaps, and box. *This is very important.* When you call for the RA number, please let Tech Support know if you need new packaging. *LOUD Technologies is not responsible for any damage that occurs due to non-factory packaging.*
5. Include a legible note stating your name, shipping address (no P.O. boxes), daytime phone number, RA number, and a detailed description of the problem, including how we can duplicate it.
6. Write the RA number in BIG PRINT on top of the box.
7. Ship the loudspeaker to us. We suggest insurance for all forms of cartage. Ship to this address:

MACKIE
SERVICE DEPARTMENT
Building #11
One Main Street
Whitinsville, MA 01588

8. We'll try to fix the loudspeaker in three to five business days. Ask Tech Support for current turnaround times when you call for your RA number. The product **MUST** be packaged in its original packing box and have the RMA number appear on the box. Once it is repaired, we'll ship it back to you the same way in which it was received. This paragraph does not necessarily apply to non-warranty service.

CARE AND MAINTENANCE



Your Mackie loudspeakers will provide many years of reliable service if you follow these guidelines:

- Avoid exposing the loudspeakers to moisture. If they are set up outdoors, be sure they are under cover if you expect rain.
- Avoid exposure to extreme cold (below freezing temperatures). If you must operate the loudspeakers in a cold environment, warm up the voice coils slowly by sending a low-level signal through them for about 15 minutes prior to high-power operation.
- Use a slightly damp cloth with a mild soap solution to clean the cabinets. Only do this when the power is turned off. Avoid getting moisture into any of the openings of the cabinet, particularly where the drivers and amplifier assembly are located.

SA1521 SPECIFICATIONS

System Specifications

<i>Frequency Range (-10 dB):</i>	49 Hz–20 kHz
<i>Frequency Response (-3 dB):</i>	57 Hz–18 kHz
<i>Horz. Coverage Angle (-6 dB):</i>	75° averaged 1 kHz to 6 kHz
<i>Vert. Coverage Angle (-6 dB):</i>	65° averaged 1 kHz to 6 kHz
<i>Sensitivity (1W@1m):</i>	100 dB
<i>Maximum SPL Long-term:</i>	130 dB @ 1m
<i>Maximum SPL Peak:</i>	133 dB @ 1m
<i>Crossover Point:</i>	1300 Hz

Transducers

Low Frequency	
<i>Diameter:</i>	15 in/381mm
High Frequency	
<i>Diaphragm Diameter:</i>	1.75 in/44mm
<i>Diaphragm Material:</i>	Titanium
<i>Exit Throat:</i>	1.00 in/28.4mm

Horn

<i>Type:</i>	Constant Directivity
<i>Mouth Size:</i>	10.6" x 10.6" (27 x 27 cm)
<i>Throat Size:</i>	1.0" (2.54 cm)

Volume Control

<i>Rotating Knob:</i>	-15 to +5 dB (0 dB detent)
-----------------------	-------------------------------

Amplifiers

Low Frequency:	
<i>Rated Output*:</i>	400 watts RMS continuous
<i>Rated THD:</i>	< 0.03 %
<i>Design:</i>	Class G, High Efficiency/ High Current

*Rated power is continuous RMS wattage into the transducer's rated impedance using a 100Hz sine wave.

High Frequency:	
<i>Rated Output*:</i>	100 watts RMS continuous
<i>Rated THD:</i>	< 0.03 %
<i>Design:</i>	Class AB

*Rated power is into the transducer's rated impedance using a 1kHz sine wave signal.

Audio Input/Output

<i>Main Input, Loop Out:</i>	50kΩ impedance, balanced
<i>Connector Type:</i>	XLR

Line Input Power

<i>US:</i>	120V, 60 Hz
<i>Recommended Amperage Service:</i>	13 amps
<i>AC Connector:</i>	3 pin IEC- Male
<i>Europe:</i>	230V, 50 Hz
<i>Recommended Amperage Service:</i>	7 amps
<i>AC Connector:</i>	3 pin IEC-Male

Control System Functions

<i>Electronic Crossover</i>
<i>Phase Alignment</i>
<i>Time Correction</i>
<i>Equalization</i>
<i>Electronic System protection</i>
<i>Thermal Overload protection</i>
<i>Independent High- and Low-Frequency Driver protection</i>

Indicator LEDs

<i>Power On:</i>	Green LED
<i>Signal Present:</i>	Green LED
<i>Limit:</i>	Yellow LED
<i>Thermal:</i>	Red LED

Safety Features

<i>RMS Limiting:</i>	Monitoring and limiting of continuous RMS output of amplifiers
<i>Thermal:</i>	Monitoring of thermal condition of power supply and amplifiers. High temperature condition engages input-stage shut down and autoreset function.

Physical

<i>Enclosure:</i>	Trapezoidal, 10° side angles, 18mm multi-layered plywood, top and bottom high-pressure resin injected "caps"
<i>Handles:</i>	One on top, one on bottom cap; one three-piece handle on each side
<i>Color:</i>	Black, PVC coated finish
<i>Grille:</i>	Custom perforated oval steel grille with anti-corrosive treatment
<i>Mounting Methods:</i>	Floor mount only—not suitable for flying Pole-mountable via built-in socket on bottom

Dimensions

<i>Height:</i>	32.0 in/81.3 cm
<i>Front Width:</i>	19.1 in/48.5 cm
<i>Rear Width:</i>	13.9 in/35.3 cm
<i>Depth:</i>	18.1 in/46.0 cm
<i>Net Weight:</i>	101.0 lb/45.8 kg

Disclaimer

Since we are always striving to make our products better by incorporating new and improved materials, components, and manufacturing methods, we reserve the right to change these specifications at any time without notice.

"Mackie." and the "Running Man" figure are registered trademarks of LOUD Technologies Inc.

All other brand names mentioned are trademarks or registered trademarks of their respective holders, and are hereby acknowledged.

©2003 LOUD Technologies Inc.
All Rights Reserved.

Architects and Engineers' Specifications

The active two-way, full-range loudspeaker system shall incorporate one 15-inch low-frequency (LF) transducer and a 1-inch exit compression driver high-frequency (HF) transducer. The LF driver shall be mounted in a vented enclosure tuned for optimum low-frequency response. The HF transducer shall be loaded on a symmetrical constant directivity horn.

The system shall have a nominal coverage pattern of 75° (horizontal) x 65° (vertical). System frequency response shall vary no more than ± 3 dB from 57Hz to 18kHz measured on axis. The loudspeaker shall incorporate a Class G low-frequency amplifier capable of delivering 400 watts RMS over a frequency range of 20Hz–1300Hz. The system shall incorporate a Class AB 100 watt RMS amplifier specifically designed to power the HF driver over the range of 1300Hz – 20kHz. The amplifiers shall be mounted on an aluminum heatsink, which shall be mounted on the rear of the speaker system, and shall be convection cooled.

Thermal protection shall be provided by a thermal sensor mounted on the heatsink, which monitors the heatsink temperature and triggers the thermal protection circuit should the temperature exceed 140° F (60° C). The thermal LED shall light and the input signal shall be muted until the heatsink cools to a safe operating level, at which point the thermal protection circuit auto-resets and normal operation resumes.

Overload protection shall be provided by a limiter circuit, which monitors the low-frequency amplifier output and reduces the input level to the amplifier should the amplifier output begin to clip.

The loudspeaker enclosure shall have a trapezoidal shape and shall incorporate two side handles and a top and bottom relocation handle. The enclosure shall be constructed of a combination multi-ply wood and high-pressure injected structural resin, with a black PVC vinyl finish. The front of the loudspeaker shall be covered with a powder coated, weather-resistant perforated steel grille.

The active two-way full-range loudspeaker system shall be a Mackie SA1521.

Dimensions

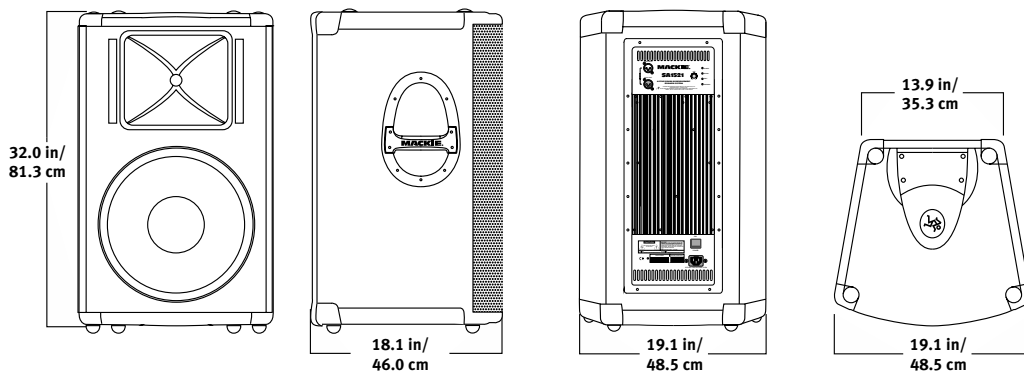

FREQUENCY RESPONSE GRAPH

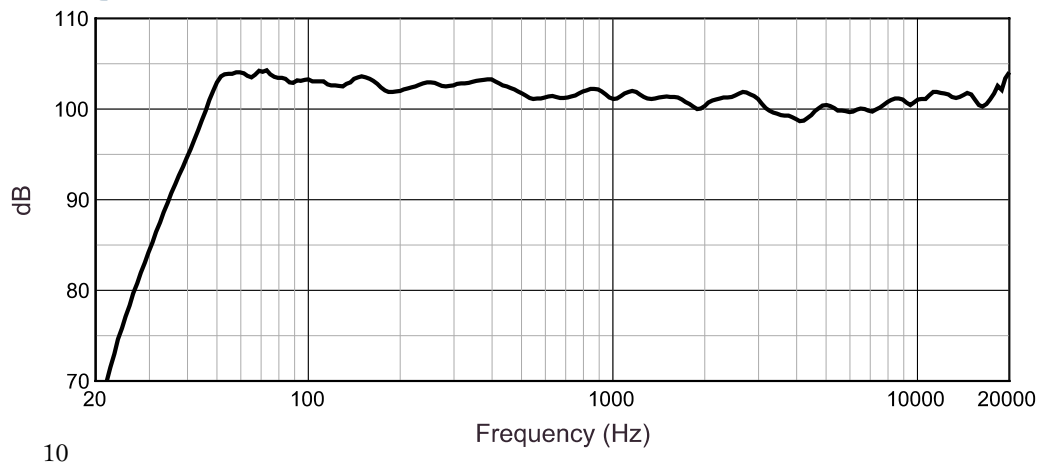

MACKIE®

SA1521 LIMITED WARRANTY

Please keep your sales receipt in a safe place.

A. LOUD Technologies Inc. warrants all materials, workmanship and proper operation of this Mackie SA1521 for a period of **five years** from the original date of purchase, with the following exception: warranty on all its loudspeaker components including woofers and compression drivers are only warranted for two years. If any defects are found in the materials or workmanship or if the product fails to function properly during the applicable warranty period, LOUD Technologies, at its option, will repair or replace the product. **This warranty applies only to equipment sold and delivered within the U.S. by LOUD Technologies Inc. or its authorized dealers.**

B. Failure to register online or return the product registration card will not void the five-year warranty.

C. Service and repairs of Mackie products are to be performed **only** at the factory (see D below) OR at an Authorized Mackie Service Center (see E below). Unauthorized service, repairs, or modification will void this warranty.

D. To obtain factory service:

1. Call Mackie Service at 800/898-3211, 7 AM to 5 PM Monday through Friday (Pacific Time) to get a Return Authorization (RA). Products returned without an RA number will be refused.

2. Pack the SA1521 in its original shipping carton. If you do not have the carton, just ask for one when you get your RA number, and we'll send a shipping carton out promptly. More information on packing can be found in the *Service* section of this manual. Also include a note explaining exactly how to duplicate the problem, a copy of the sales receipt with price and date showing, and your return street address (no P.O. boxes or route numbers, please!). If we cannot duplicate the problem or establish the starting date of your Limited Warranty, we may, at our option, charge for service time.

3. Ship the product in its original shipping carton, **freight prepaid** to:

**MACKIE
SERVICE DEPARTMENT
One Main Street
Whitinsville, MA, 01588, USA**

IMPORTANT: Make sure that the RA number is plainly written on the shipping carton.

E. To obtain service from an Authorized Mackie Service Center:

1. Call Mackie Service at 800/898-3211, 7 AM to 5 PM Monday through Friday (Pacific Time) to get: 1) The name and address of your nearest Authorized Mackie Service Center and 2) A return authorization (RA). You must have an RA number before taking your unit to a service center.

2. Make sure that you have a copy of your loudspeaker's sales receipt from the store where you bought the product. It is necessary to establish purchase date and thus determine whether or not your loudspeaker is still under warranty. If you can't find it, the Authorized Service Center may charge you for repairs even if your loudspeaker is still covered by the Five-Year Limited Warranty.

3. Make sure that the problem can be duplicated. If you bring your loudspeaker to an Authorized Service Center and they can't find anything wrong with it, you may be charged a service fee.

4. If the Authorized Mackie Service Center is located in another city, pack the loudspeaker in its original shipping carton. More information on packing can be found in the *Service* section of this manual.

5. Contact the Authorized Mackie Service Center to arrange service or bring the loudspeaker to them.

F. LOUD Technologies and Authorized Mackie Service Centers reserve the right to inspect any products that may be the subject of any warranty claims before repair or replacement is carried out. LOUD Technologies and Authorized Mackie Service Centers may, at their option, require proof of the original date of purchase in the form of a dated copy of the original dealer's invoice or sales receipt. Final determination of warranty coverage lies solely with LOUD Technologies or its Authorized Service Centers.

G. Mackie loudspeakers returned to LOUD Technologies and deemed eligible for repair or replacement under the terms of this warranty will be repaired or replaced within thirty days of receipt by LOUD Technologies. LOUD Technologies may use refurbished parts for repair or replacement of any product. Products returned to LOUD Technologies that do not meet the terms of this Warranty will be repaired and returned C.O.D. with billing for labor, materials, return freight, and insurance. Products repaired under warranty at the factory will be returned freight prepaid by LOUD Technologies to any location within the boundaries of the USA.

H. LOUD Technologies warrants all repairs performed on Mackie products for 90 days or for the remainder of the original warranty period. LOUD Technologies assumes no responsibility for the quality or timeliness of repairs performed by Authorized Mackie Service Centers.

I. This warranty is extended to the original purchaser and to anyone who may subsequently purchase this product within the applicable warranty period.

J. This is your sole warranty. LOUD Technologies does not authorize any third party, including any dealer or sales representative, to assume any liability on behalf of LOUD Technologies or to make any warranty for LOUD Technologies Inc.

K. THE WARRANTY GIVEN ON THIS PAGE IS THE SOLE WARRANTY GIVEN BY LOUD TECHNOLOGIES AND IS IN LIEU OF ALL OTHER WARRANTIES, EXPRESS AND IMPLIED, INCLUDING THE WARRANTIES OF MERCHANTABILITY AND FITNESS FOR A PARTICULAR PURPOSE. THE WARRANTY GIVEN ON THIS PAGE SHALL BE STRICTLY LIMITED IN DURATION TO FIVE YEARS FROM THE DATE OF ORIGINAL PURCHASE FROM AN AUTHORIZED MACKIE DEALER. UPON EXPIRATION OF THE APPLICABLE WARRANTY PERIOD, LOUD TECHNOLOGIES INC. SHALL HAVE NO FURTHER WARRANTY OBLIGATION OF ANY KIND. LOUD TECHNOLOGIES INC. SHALL NOT BE LIABLE FOR ANY INCIDENTAL, SPECIAL, OR CONSEQUENTIAL DAMAGES THAT MAY RESULT FROM ANY DEFECT IN THE MACKIE PRODUCT OR ANY WARRANTY CLAIM. Some states do not allow exclusion or limitation of incidental, special, or consequential damages or a limitation on how long warranties last, so some of the above limitations and exclusions may not apply to you. This warranty provides specific legal rights and you may have other rights which vary from state to state.

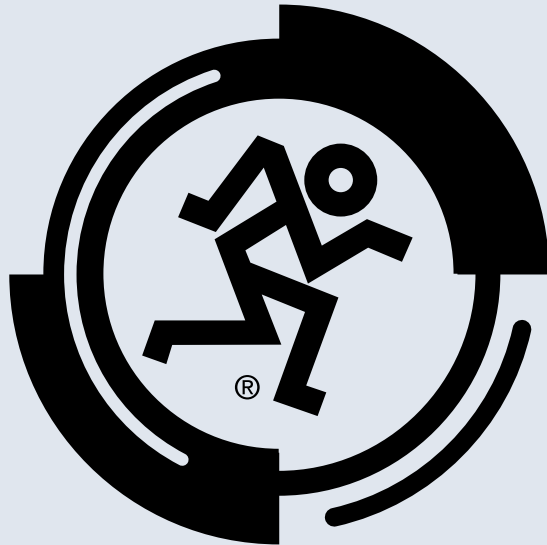

MACKIE®

16220 Wood-Red Road NE • Woodinville, WA 98072 • USA

US and Canada: 800.898.3211

Europe, Asia, Central and South America: 425.487.4333

Middle East and Africa: 31.20.654.4000

Fax: 425.487.4337 • www.mackie.com

E-mail: sales@mackie.com