

MACKIE®

digital **Xbus**



QUICK-START GUIDE
X.200

Table of Contents

Introduction..... 3

Getting Started 4

Connections 4

I/O Cards 4

 1. MIC/LINE 4 CARD 4

 2. MIC/LINE 8 CARD 4

 3. LINE CARD 4

 4. DIGITAL CARD 5

 5. AES/EBU CARD 5

 6. FIREWIRE CARD 5

 7. MIX OUT CARD 5

 8. SYNC CARD 6

Other Connections..... 6

 9. FOOT SWITCH 1 and 2..... 6

 10. SERIAL 9 PIN 6

 11. MIDI IN and OUT 6

 12. ETHERNET 6

 13. USB 6

 14. IEC Power Receptacle 6

 15. Power Switch..... 7

More Connections..... 7

 16. Mouse..... 7

 17. Keyboard..... 7

 18. USB..... 7

Operational Basics 8

 Turning on the Digital X Bus..... 8

 About Fader Banks 8

 About V-Pot Controls 8

 Touchscreens..... 8

 Keyboard and Mouse..... 8

Getting Sound Happening 9

Hookup Diagrams 12

Don't forget to visit our website at www.mackie.com for more information about this and other Mackie products.



Introduction

Thank you for choosing a Mackie Digital X Bus for your next-generation digital recording console. The Digital X Bus offers you the flexibility to configure it for virtually any recording application through its extended card cage and I/O routing options. It was designed with the ability to upgrade as advancements are made in digital recording technology. But with 32-bit floating point processing, you have more power than just about any other digital mixing console in its class.

We know you want to get started right away, so this Quick-Start Guide is designed to help you get up and running quickly. If you have any experience using a digital mixing console, like our D8B, you'll find that using the Digital X Bus is very similar and you'll be mixing away in no time. If this is your first experience with digital mixing, we'll run you through some of the unique aspects of using a digital mixing console. You will find that once you've learned these differences and the incredible flexibility that digital mixing has to offer, you will have a very short learning curve, and wonder how you have lived without the power of digital mixing for so long.



Note: As new software releases become available, they can be downloaded from the Mackie website by going to the Digital X Bus webpage at:

<http://www.mackie.com/products/digitalxbus>.

You will need a USB flash drive (a.k.a. thumb-drive) to transfer the installer package from your computer to the Digital X Bus. Installation instructions are also available on the website.

HOW TO USE THIS MANUAL

We know that many of you can't wait to get your new Digital X Bus hooked up, and you're probably not going to read the manual first (sigh!). So this Quick-Start Guide will help you get the mixer set up fast so you can start using it right away. After the "Getting Started" section, we have included some hook-up diagrams that show typical connections for tracking, mixdown, and using the Digital X Bus with a DAW (Digital Audio Workstation).

Then, when you have time, read the owner's manual. It describes every knob, button, and slider on the console, and all the menus and windows on the touchscreens.

Please write your serial number here for future reference (i.e., insurance claims, tech support, return authorization, etc.)

Purchased at:

Date of purchase:

Getting Started

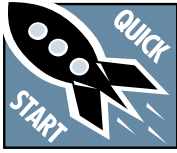

Once you've unpacked your new Digital X Bus, you'll want to position it where you can sit comfortably and reach the touchscreens and controls, and have relatively easy access to the rear panel, in case you need to make any changes to the connections. Typically, once you've set it up and made the connections, you won't have to make any changes unless you change your external equipment.

Connections

The Digital X Bus comes with a Mix Out card (control room card) and a Sync card already installed in the card cage in the rear panel. There are also connections for a USB mouse and keyboard (see "More Connections" for PS/2-style mouse and keyboard connections). While not required to operate the Digital X Bus, they can be handy for quickly entering data or when clicking is easier than touching (the touchscreen).

Beyond that, we have a variety of analog and digital I/O cards, not included with the base model, that you can install in the card cage to suit your application. This allows you to match the I/O connections on your Digital X Bus with the I/O connections provided on the other equipment in your studio. Here's a quick run-down of what we offer:

I/O Cards

1. MIC/LINE 4 CARD

This card has four female XLR balanced microphone inputs, and four 1/4" TRS balanced/unbalanced line-level inputs, for a total of eight analog inputs. Note that this card does not provide any outputs.

2. MIC/LINE 8 CARD

The Mic/Line 8 card has two DB25 connectors, one for inputs and one for outputs. The input connector accepts eight balanced mic/line-level inputs. The output connector provides eight balanced line-level outputs. These DB25 connectors use the TASCAM standard pinout for analog signal connections (the same standard used on the analog cards for the Mackie D8B and Hard Disk Recorder). If you are connecting these to another device using the same DB25 standard, you can use a DB25-to-DB25 audio cable. Otherwise, you will need to use DB25 cables that breakout to XLR, 1/4" TRS, or TT connectors.

3. LINE CARD

The Line card has two DB25 connectors. One provides eight balanced line-level inputs, and the other provides eight balanced line-level outputs. They use the TASCAM standard pinout for analog signal connections (the same standard used on the analog cards for the Mackie D8B and Hard Disk Recorder). If you are connecting these to another device using the same DB25 standard, you can use a DB25-to-DB25 audio cable. Otherwise, you will need to use DB25 cables that breakout to XLR, 1/4" TRS, or TT connectors.

Refer to Appendix B in the Digital X Bus X.200 Owner's Manual for a wiring diagram of these connectors.

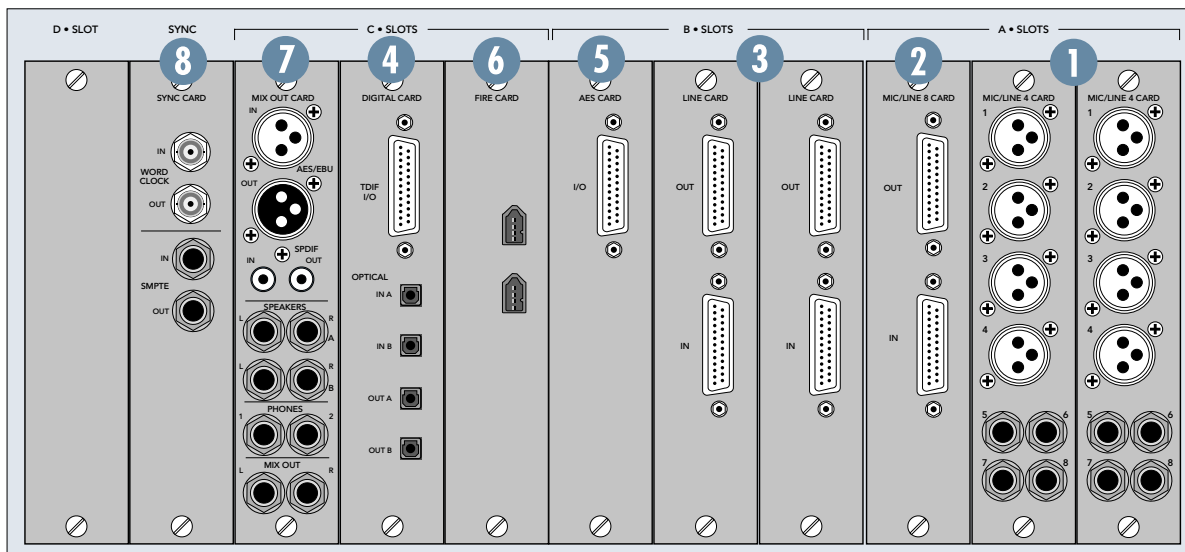

4. DIGITAL CARD

This card provides eight channels of digital I/O in two formats; TDIF on a DB25 connector and ADAT optical on four TOSLINK connectors.

At 44.1/48 kHz sample rates, each optical TOSLINK connector provides either eight inputs or eight outputs of digital audio. At 88.2/96 kHz sample rates, the S/MUX protocol is used to provide channels 1-4 on the "A" connectors, and channels 5-8 on the "B" connectors. At 176.4/192 kHz sample rates, the S/MUX II protocol is used to provide channels 1-2 on the "A" connectors and channels 3-4 on the "B" connectors, for a total of four inputs and outputs.

5. AES/EBU CARD

The AES/EBU card has one DB25 connector, providing eight channels of digital I/O in the AES/EBU format.

The original AES/EBU specification (IEC958 Type 1) provides for carrying two channels of digital audio at resolutions up to 24-bit at 48 kHz. When higher sampling rates became possible, two methods were developed to transmit digital audio at the higher sample rates — double-fast and double-wide.

The double-fast method (also called single-wire) clocks the digital I/O port at twice the speed to get twice the information through, providing support for resolutions up to 24-bit at 96 kHz.

The double-wide method (also called dual-wire) transmits one channel of digital audio instead of two channels through a single digital I/O port, again providing support for resolutions up to 24-bit at 96 kHz.

The AES/EBU card currently uses the double-fast method, so eight channels of digital I/O are supported up to 192 kHz.

At sampling rates up to 48 kHz, two channels of digital audio are transmitted on a single wire (one 3-pin XLR) at normal speed as specified by the AES/EBU standard.

At sampling rates of 88.2/96 kHz, two channels of digital audio are transmitted on a single wire (one 3-pin XLR) at twice the normal speed (2x).

At sampling rates of 176.4/192 kHz, two channels of digital audio are transmitted on a single wire (one 3-pin XLR) at four times the normal speed (4x).

Note: Check the owner's manual for the device you are connecting to the AES/EBU card, to find out if it supports the double-fast (or single-wire) method.

6. FIREWIRE CARD

The FireWire card uses the IEEE-1394 protocol for connecting digital devices. It currently provides 24 inputs and 24 outputs of digital audio at 48 kHz, and 8 inputs and 8 outputs at 96 kHz (with room for improvement as driver technology improves). It supports OS X Core Audio applications on the Macintosh, and Windows XP ASIO applications on the PC.

7. MIX OUT CARD

This provides several outputs (with the addition of an AES/EBU and S/PDIF input), typically used for control room, headphones, and main outputs.

AES/EBU IN and OUT

These are XLR connectors that accept and send standard AES/EBU two-channel digital signals.

S/PDIF IN and OUT

These are RCA-type connectors that accept and send standard S/PDIF two-channel digital signals.

SPEAKERS A and B

These are two sets of stereo monitoring outputs using 1/4" TRS jacks. They produce a line-level analog signal that you can connect to the inputs of the amplifier powering your control room monitors (or the inputs to your active studio monitors). You might use one pair (A) for near-field monitor speakers and the other pair (B) for your main monitor speakers. These are assigned to the Control Room Left and Right outputs by default, but can be reassigned to virtually any input or output source.

The Control Room source is selected in the CONTROL ROOM section of the console (press the SETUP button in the CONTROL ROOM section for more setup options).

PHONES 1 and 2

These are stereo 1/4" TRS jacks that provide a stereo output for headphones, or for connecting to a headphone distribution box. These are assigned to the Phones 1 and Phones 2 outputs by default, but can be reassigned to virtually any input or output source.

The Phones 1 and 2 sources are selected in the PHONES 1 or PHONES 2 section on the console (press the SETUP button in the PHONES section for more setup options).

MIX OUT

These are balanced 1/4" TRS jacks that provide a line-level analog signal. These are assigned to the left and right mix outputs by default, but can be reassigned to virtually any input or output source. Connect these outputs to the inputs of a 2-track recorder for mixdown, or to the inputs of a power amplifier to drive a pair of speakers for the studio or whatever.

8. SYNC CARD

The Sync card provides the digital word clock in and out on a pair of BNC connectors, and SMPTE time code in and out on a pair of 1/4" jacks.

Sync data is also transmitted through the ADAT lightpipe and AES/EBU connections. The Sync card just provides another means to transmit and receive the word clock. This is particularly useful when you want the Digital X Bus to be the master clock for your digital audio system.

Time code is also provided through MIDI time code (MTC). SMPTE time code is more commonly used in motion picture and broadcast applications.

Other Connections

In addition to the cards in the card slots, there are more connections you can make on the rear panel.

Note: The D•SLOT is reserved for use with the X.400 model and is not used with the X.200.

9. FOOT SWITCH 1 and 2

These two 1/4" TS jacks are provided for foot-switch control of various functions. These functions are assignable in the Windows > Setup window, and include Talkback, Play/Stop, Next Marker, Previous Marker, and New Marker.

10. SERIAL 9 PIN

This DB9 connector is an RS-422 port that supports the Sony® 9-Pin device protocol. It is configured to operate as a controller, so it should be connected to a device (DEV) that is configured to be controlled by a controller (CONT). This is used primarily to transmit tape transport commands from the Digital X Bus to a recorder.

11. MIDI IN and OUT

These standard MIDI connectors (female 5-pin DIN) can be used to send or receive MIDI Time Code (MTC) and MIDI Machine Control (MMC) when connecting to equipment with transport controls and a position display.

The MIDI connectors can also be used to control your DAW application when the MIDI fader bank is selected (DAW Bank).

You can turn MTC on and off in the Sync Card setup window (Windows > I/O Configuration and touch the Sync card) by clicking the Generate MTC box. You can select MTC as the time code source in the same setup window by clicking the Time Code Source dropdown box and selecting MIDI (MTC).

12. ETHERNET

The Ethernet connector is reserved for future upgrades.

13. USB

The two USB ports on the Digital X Bus can be used to connect a USB equipped mouse, keyboard, or USB memory stick (USB flash drive). See “More Connections” on the next page to see how to connect more USB devices, and a PS/2-style keyboard and mouse with a 6-pin miniDIN connector.

14. IEC Power Receptacle

There are two power receptacles on the Digital X Bus, one to provide power to the Digital X Bus and the other to connect to another device and provide power to it. These are standard 3-prong IEC power connectors. Connect the detachable linecord (included with your Digital X Bus) to the male power receptacle, and plug the other end of the linecord into an AC outlet with the correct voltage for your particular Digital X Bus.

To connect another device to the female IEC power receptacle, you need a power cord with a male IEC power connector on one end, and a female IEC power connector on the other end. These can be purchased at most electronic supply stores.

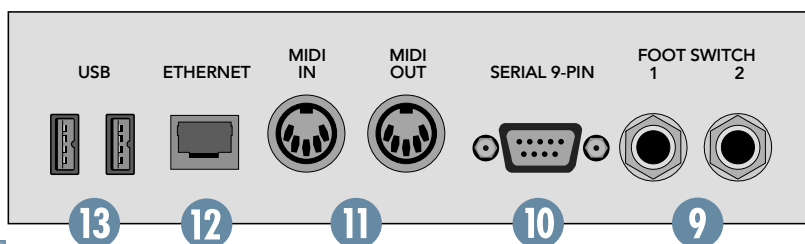

15. Power Switch

This one is self-explanatory. When the POWER switch is turned ON, power is supplied to the Digital X Bus and it boots up. When turning off the Digital X Bus, you should select Shutdown from the File menu. At the end of the shutdown procedure, the touchscreens go blank, indicating that it is okay to turn off the power switch.

More Connections

There are even more connections available behind the removable panel on the back of the Digital X Bus, which we call the Motherboard Access Area. These are connections to the motherboard, and include four additional USB connections, and the PS/2-style mouse and keyboard connections.

To access the connectors:

1. First, turn off the Digital X Bus (select File > Shutdown and then turn off the power switch).
2. Use a Phillips screwdriver to remove the eight screws securing the panel to the chassis.

16. Mouse

This 6-pin miniDIN connector is used to connect a PS/2-style mouse.

17. Keyboard

This 6-pin miniDIN connector is used to connect a PS/2-style keyboard.

18. USB

These are four additional USB ports for connecting more USB devices to the Digital X Bus. If you are connecting a USB CD-ROM drive, use one of these ports rather than the USB ports on the rear panel (13).

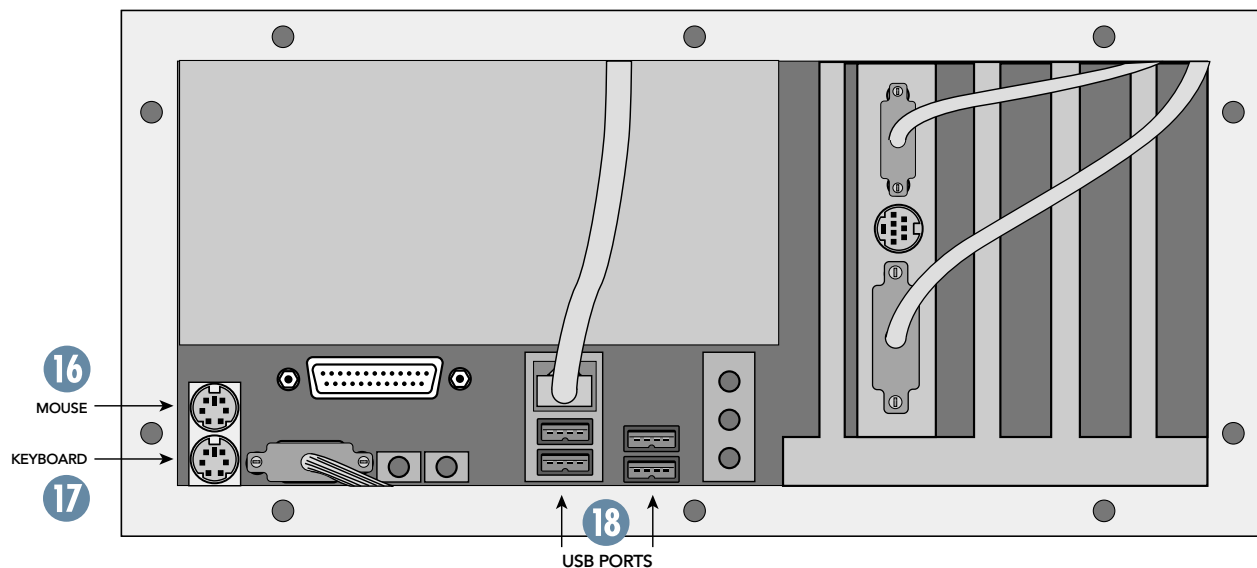

Operational Basics

Are you ready to get started? Let's turn on the Digital X Bus and go over some of the general operational features before we start passing audio through it.

Turning on the Digital X Bus

Connect the supplied power cord to the male IEC connector on the rear panel. Plug the other end of the power cord into an outlet properly configured for the voltage indicated on your particular model. Turn on the power switch. The faders start moving and the Digital X Bus loads its software into memory. This may take up to 60 seconds. When the screens display the channels strips, you're ready to go.

About Fader Banks

If you have used a digital console before, then you are probably familiar with the concept of fader banks. Unlike an analog board, a digital mixing console can reassign a channel strip to route any input to any output. This can be done on an individual channel basis, or globally, by switching banks and reassigning all 24 channel strips at once.

You can think of each bank as a separate layer of controls, stacked one on top of each other. The X.200 has six banks:

1-24
25-48
49-72
MASTERS
GROUPS
MIDI

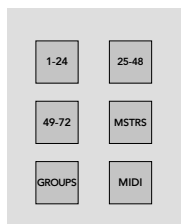

Thus, 24 channels strips suddenly become 144 channels (24 channels x 6 banks = 144 channels)!

The first three banks, channels 1-72, provide a 72x72 channel I/O matrix. With nine I/O cards installed, you can have 72 individual inputs and outputs (8 inputs/outputs x 9 cards = 72 inputs/outputs).

The MASTERS bank is used for the 12 Aux Send masters, 8 Bus masters, and the L/R mix master.

The GROUPS bank has the controls for Groups 1-12, and for 12 MIDI channels.

The MIDI bank is used to convert the Digital X Bus into a control surface for any DAW that supports the Mackie Control Universal protocol. You can select the DAW you are using from an emulation mode box to configure the MIDI bank to work with your particular DAW via the MIDI IN/OUT connectors.

About V-Pot Controls

Just below the touchscreens are a row of rotary controls called V-Pots, which is short for virtual potentiometer. Again, unlike an analog console where a rotary pot can control one function, a digital console allows you to assign a V-Pot to many different functions.

Using the buttons to the right of the touchscreens, you can assign the V-Pots to control the following functions:

PAN L/R (Left/Right)
PAN F/B (Front/Back,
for surround sound)
AUX 1-8 Send
AUX 9/10 and 11/12 Send
AUX 9/10 and 11/12 PAN
Digital TRIM
LEVEL TO TAPE

When one of the above buttons is selected (lit), all 24 V-Pots control that function for each of the 24 channels in the selected bank. What would take 384 controls on an analog console can be done with 24 controls and 16 buttons on the Digital X Bus!

In addition, windows that contain adjustable parameters, like the Dynamics and EQ windows, have their controls situated above the channel V-Pots, which temporarily become controls for the parameters in the window, overriding the V-Pot Assign selection. As soon as the window is closed, V-Pot control returns to whatever is selected in the V-Pot Assign section.

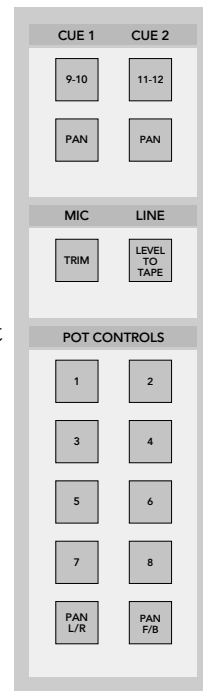

Touchscreens

Although using the touchscreens may seem unfamiliar at first, the touchscreen interface will quickly become second-nature to you. The dual 15" TFT touchscreens not only give you a detailed, high-definition view of what is happening with the Digital X Bus, but they also give you almost instant access to alternate screens, settings, and controls. As you become familiar with navigating the touchscreen interface, you will find yourself accessing screens and controls with increasing speed and efficiency.

Keyboard and Mouse

In addition to the touchscreens, you can use a keyboard and mouse to select and change controls on the Digital X Bus. Use a keyboard to enter keyboard shortcuts (hot keys), or to enter letters and numbers whenever a keyboard graphic appears on-screen. Use the mouse to click on-screen where you would otherwise touch to open, close, or select something.

Getting Sound Happening

The following procedure demonstrates how to connect a microphone to an input and get sound out of the Digital X Bus.

Here's what you'll need:

- 1 stereo power amplifier
- 1 pair of monitor speakers (you can substitute a pair of powered monitors for the power amplifier/monitor speaker combo, or a set of stereo headphones)
- 1 microphone
- Appropriate cable to connect the microphone to your particular input card
- Cables to connect the speaker outputs to the amplifier or powered monitor speakers

Here's what you do:

1. Turn on the Digital X Bus.
2. Connect a microphone to Input 1. If you are using a MIC/LINE 8 card, use a DB25-to-XLR female breakout cable to connect the microphone to Input 1. If you are using a MIC/LINE 4 card, you can plug the XLR microphone cable directly into the card.

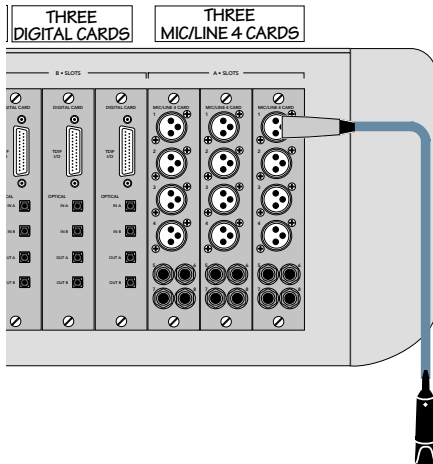

3. Press the Bank 1 button (1-24) in the Banks section of the console (just above the Master fader).

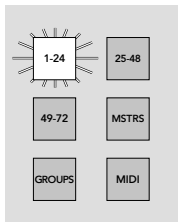

4. Press the SELECT button on channel 1.



5. Make sure channel 1 has Input 1 assigned to it. Open the Assign window (Windows > Assign). Under the Input Src drop-down box select Mic Line In. 1.



6. If the microphone requires phantom power, select the 48V button in the Assign window to turn on phantom power. Leave the -10 dB pad off when using a microphone.
7. Talk or sing into the microphone and adjust the Gain control using the V-Pot on channel 1 so the meter indicates between -12 and -6.



8. In the Assign window, make sure L-R is selected under Bus Assigns.



9. Connect the Left and Right Speaker Outs (A) from the Mix Out card to the inputs of your stereo power amplifier (or powered monitor speakers). These outputs are balanced when using a TRS (tip-ring-sleeve) connector, or unbalanced when using a TS (tip-sleeve) connector. Use instrument/line-level cable for this connection. If using a stereo power amplifier/speaker combo, connect the amplifier outputs to the monitor speakers using appropriate speaker cable.
10. If you don't have an amplifier and speakers handy, you can connect a pair of headphones to the Phones 1 output on the Mix Out Card.
12. If you are using headphones instead of speakers, turn the Phones 1 level control all the way down in the PHONES 1 section on the right side of the console. Make sure L-R is selected as the source in the CONTROL ROOM section, and C/R is selected as the source in the PHONES 1 section.
13. Press the MSTRS button in the Banks section of the console. Set the Mix L and Mix R faders to unity (U). These two faders are stereo-linked by default.
14. Set channel 1 fader to unity (U).
15. Set the Master fader to unity (U).

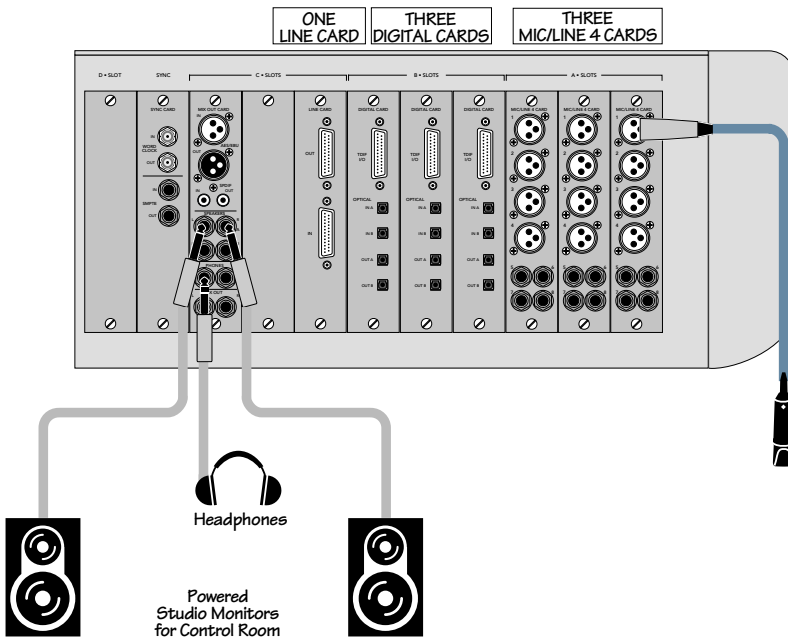

16. Turn on the power amplifier (or powered monitor speakers). Set the level controls on the power amplifier to the manufacturers recommended setting.

17. Talk or sing into the microphone while slowly turning up the level control in the CONTROL ROOM section. You should hear sound in the speakers and see the L/R meters at the top of the touchscreen display levels.

18. If you are using headphones, turn the level control in the CONTROL ROOM section up about halfway, then SLOWLY turn up the level control in the PHONES 1 section. You should hear sound in the headphones.

11. In the CONTROL ROOM section on the right side of the console, turn the level control all the way down (counterclockwise), and select L-R for the source and NEAR (Speaker Out A) for the output.

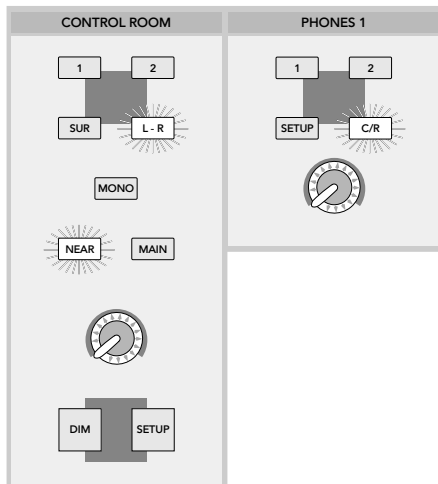

To patch an effect into the signal path:

19. Open the Effects Rack (Windows > Effects Rack).
20. Click the New Plugin button and select Reverb in the NEW PLUGIN window, then click OK.

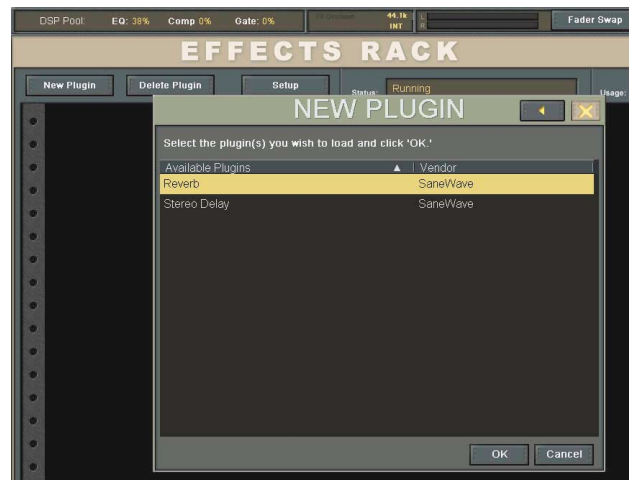

- In the Reverb panel, click the Src L drop-down box and select Channel Post Insert > Ch. 1 Post. This places the reverb in the post-insert loop on channel 1.

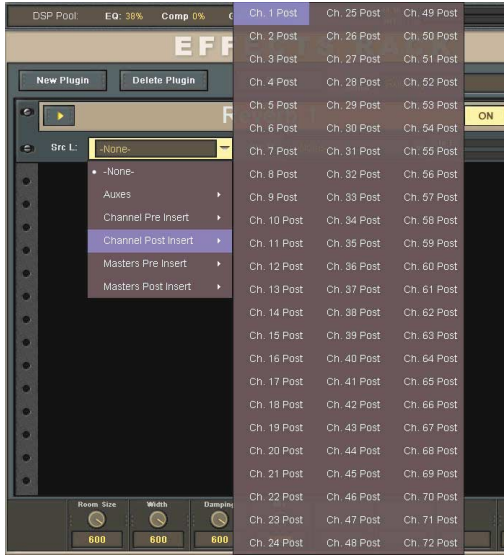

- Adjust the reverb parameters using the V-Pots at the bottom of the Effects Rack. You should see the Left Input and Output meters move as you talk or sing into the microphone.

Note: A more typical use for an effect in the Effects Rack might be to route several channels to an Aux Send; for example, all the background vocals to Aux Send 1. Route Aux Send 1 to the input of the effect in the Effects Rack by selecting it in the Src (Source) drop-down box. The Aux 1 master fader (Masters Fader Bank) is used to control the amount of signal being sent to the effect. Return the effects signal to the signal path by selecting the effect's output for the input of an unused channel.

To write some basic automation:

- In the AUTOMATION MODES section of the console, select FADER and MUTE. Turn off the BYPASS button.

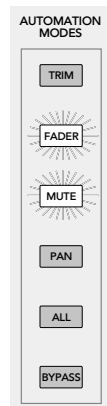

- Select the WRITE button in the ASSIGN BUTTON SETUP section of the console. Press the ASSIGN button on channel 1.



- Start running time code by pressing the PLAY button in the Transport section of the console. You can see the time code in the upper-right corner of the screen.

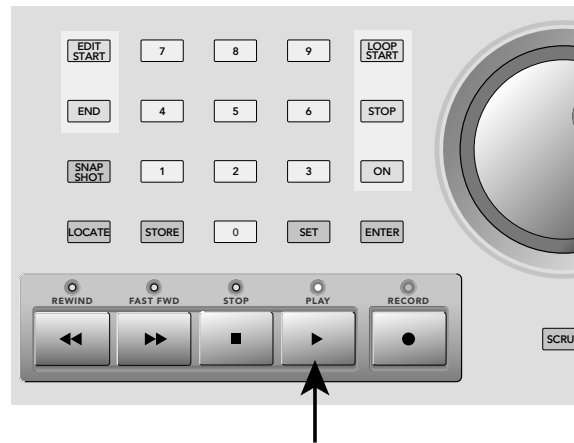

- Move the channel 1 fader up and down a few times and press the mute button on channel 1.
- Press the STOP button in the Transport section and press REWIND to return the time code to zero.
- Press the PLAY button and the fader moves and mute will playback from automation.
- You can open the Mix Editor (Windows > Mix Editor) to see the automation moves. Select Channels > Ch. 1 in the Show drop-down box at the top of the Mix Editor to see the recorded fader moves and mute action relative to the time code.



Hookup Diagrams

One of the primary applications for the X.200 is multitrack recording. This involves tracking and monitoring, bouncing, overdubbing, and mixdown. A typical application might involve 24 inputs for tracking and 24 outputs to a multitrack recorder or DAW (Digital Audio Workstation). In this case, you might have three MIC/LINE 4 CARDS installed in slots 1-3 (A•SLOTS) for 24 analog inputs, and three DIGITAL CARDS installed in slots 4-6 (B•SLOTS) for 24 digital outputs. By assigning the Output Source for the 24 digital outputs to Channels 1-24, you can record each input channel to an individual track on the multitrack recorder.

The hookup diagrams in this section demonstrate how the connections are made with the Digital X Bus X.200 for tracking and mixdown, mixdown to surround sound, and using a DAW.



TRACKING and MIXDOWN

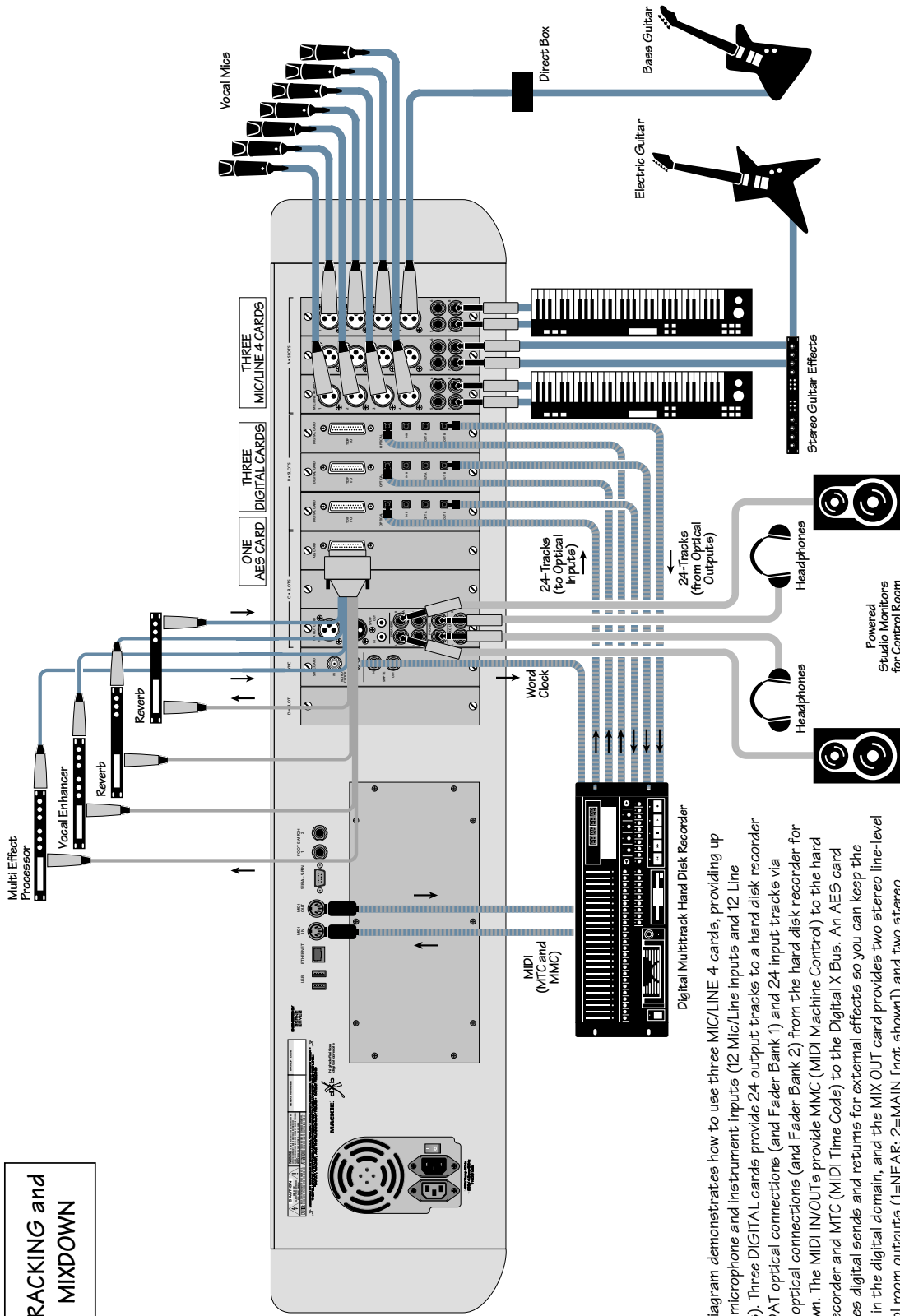

This diagram demonstrates how to use three MIC/LINE 4 cards, providing up to 24 microphone and instrument inputs (12 Mic/Line inputs and 12 Line inputs). Three DIGITAL cards provide 24 output tracks to a hard disk recorder via ADAT optical connections (and Fader Bank 1) and 24 input tracks via ADAT optical connections (and Fader Bank 2) from the hard disk recorder for mixdown. The MIDI IN/OUTs provide MMC (MIDI Machine Control) to the hard disk recorder and MTC (MIDI Time Code) to the Digital X Bus. An AES card provides digital sends and returns for external effects so you can keep the signal in the digital domain, and the MIX OUT card provides two stereo line-level control room outputs (1=NEAR; 2=MAIN [not shown]) and two stereo headphone outputs for monitoring the input sources.

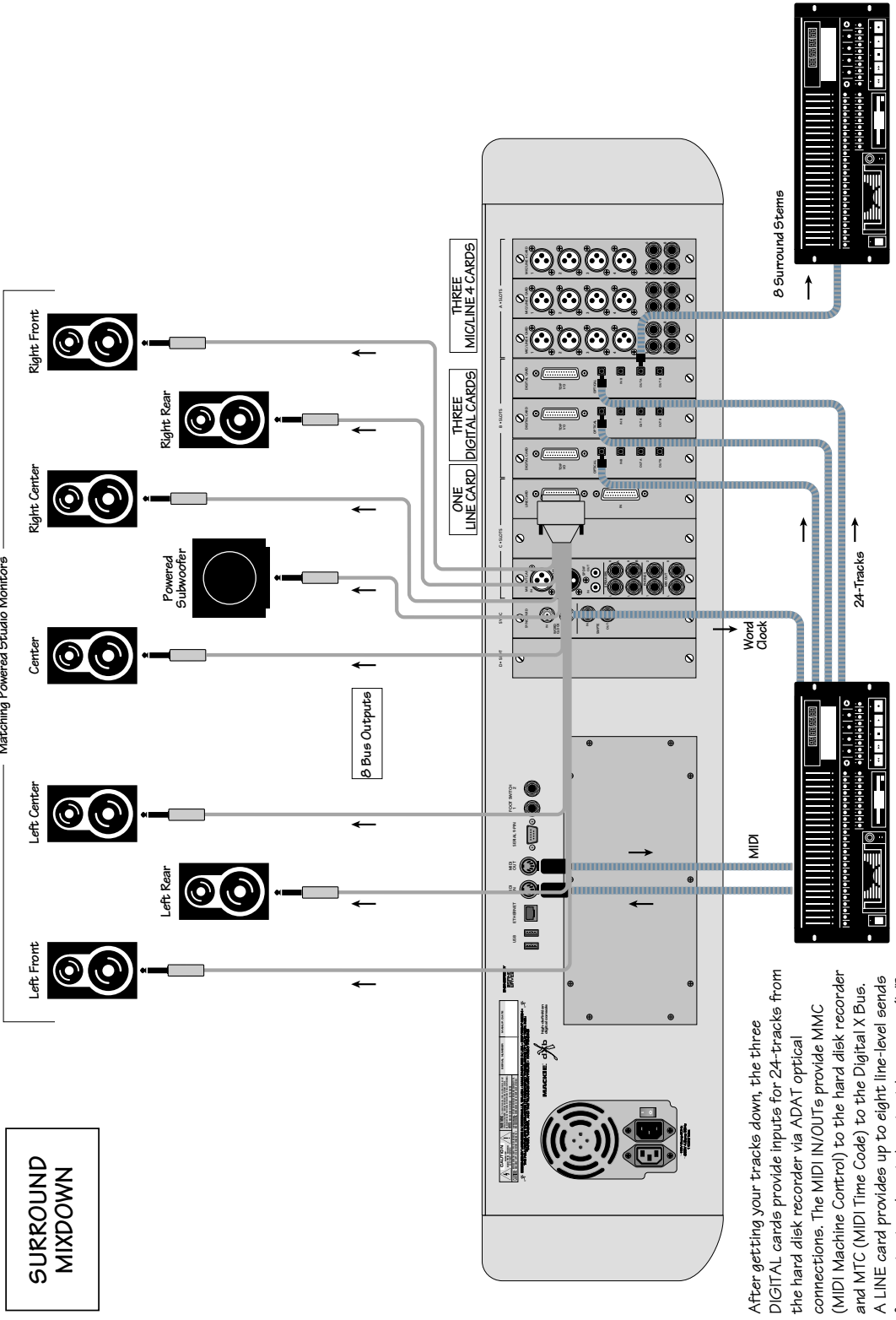

After getting your tracks down, the three DIGITAL cards provide inputs for 24-tracks from the hard disk recorder via ADAT optical connections. The MIDI IN/OUTs provide MMC (MIDI Machine Control) to the hard disk recorder and MTC (MIDI Time Code) to the Digital X Bus. A LINE card provides up to eight line-level sends for monitoring the mixdown in either stereo (L/R Mix) or surround sound. You can use the AES/EBU or S/PDIF outputs (or the analog MIX OUT) from the MIX OUT card to record a stereo mixdown, or one of the ADAT optical outputs to record the surround stems to a digital multitrack recorder.

This example demonstrates how to use the Digital X Bus with a digital audio workstation (DAW). Three MIC/LINE 4 cards provide up to 24 microphone and instrument inputs (12 Mic/Line inputs and 12 Line inputs). Three AES cards provide 24 output tracks to the DAW's audio interface via 25-pin AES/EBU connections. The SMPTE IN/OUTs on the SYNC card provide time code for the DAW. Two MIDI interfaces are used to achieve full 24-channels of MIDI communication between the Digital X Bus and the DAW via the USB. A LINE card provides line-level sends and returns for external effects, or better yet, use the Internal Effects Rack in the Digital X Bus loaded with VST effects and eliminate the need for expensive external signal processors. The MIX OUT card provides a stereo line-level control room output and two stereo headphone outputs for monitoring the input sources.

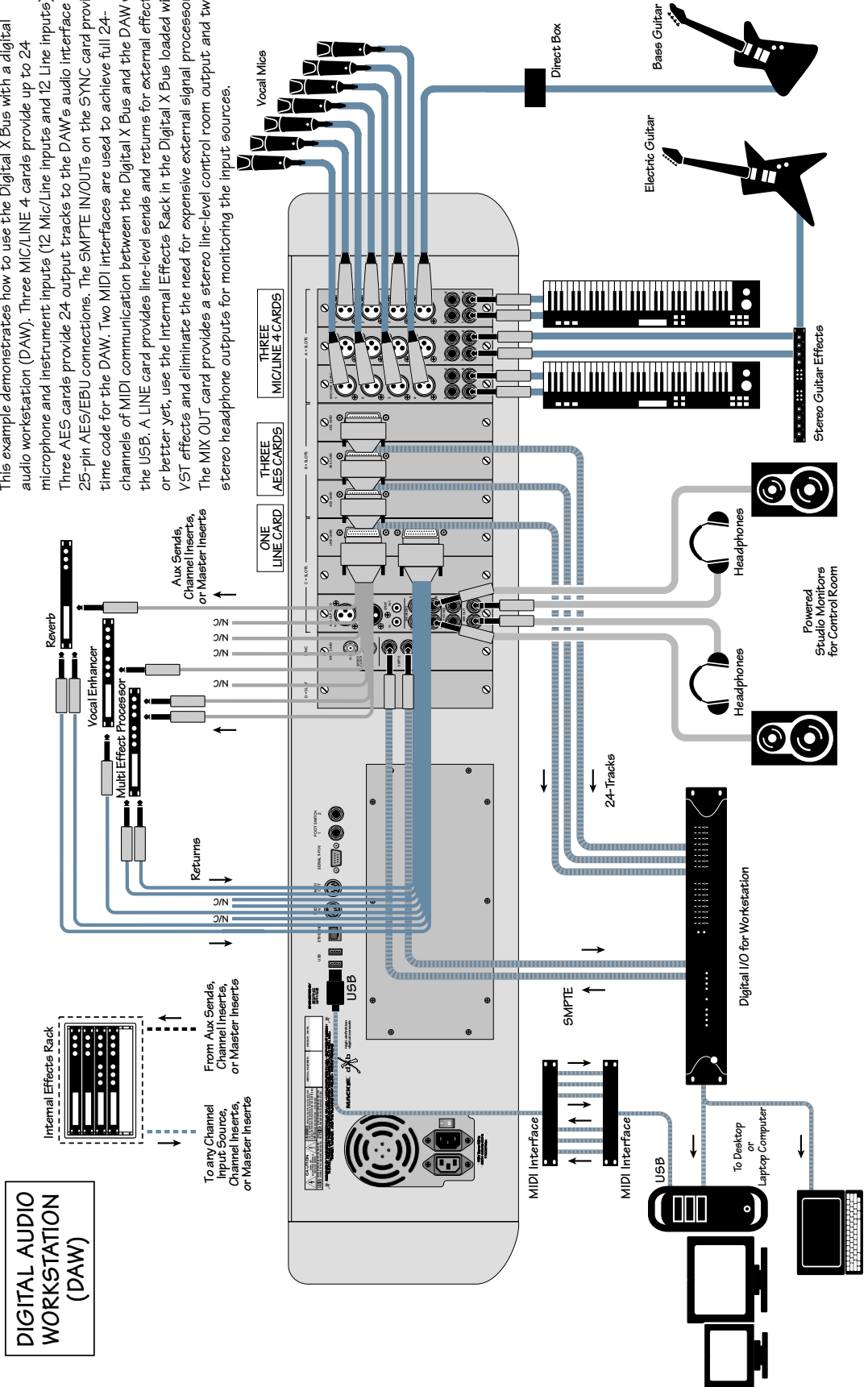

DIGITAL AUDIO WORKSTATION (DAW)

Reverb
Vocal Enhancer
Multi Effect Processor

Aux Sends, Channel Inserts, or Master Inserts

Internal Effects Rack

From Aux Sends, Channel Inserts, or Master Inserts

Returns

THREE MIC/LINE 4-CARDS

THREE AES-CARDS

ONE LINE-CARD

Direct Box

Electric Guitar

Bass Guitar

Stereo Guitar Effects

Digital I/O for Workstation

Desktop or Laptop Computer

MIDI Interface

MIDI Interface

USB

SMPTE

24-Tracks

Headphones

Headphones

Powered Studio Monitors for Control Room

MACKIE®

16220 Wood-Red Road NE • Woodinville, WA 98072 • USA
www.mackie.com • sales@mackie.com

United States and Canada: 800.898.3211
Fax: 425.487.4337

Europe, Asia, Central and South America: 425.487.4333
Middle East and Africa: 31.20.654.4000