

Art Series

■ The same careful acoustic design and advanced materials used in the ART active speakers have been utilized in the ART300 passive speaker. Combining high efficiency, high power handling and excellent sonic performance, the ART300 provides practical solutions for permanent installation applications.

■ The two-way design consists of a 12" woofer that uses a massive magnet structure for accurate bass reproduction and a CD horn loaded to a 1" exit compression driver. The CD horn is a part of the molded enclosure.

■ The system includes a high-level crossover network that features oversized inductors in series with the woofer. The benefit is improved current handling, reduced phase shift and superior transient response. Dynamic high-frequency driver protection is accomplished with a fast-response filament resistor, chosen to compliment the power curve of the driver.

■ All components are housed in a lightweight, vented enclosure formed from polypropylene that is extremely rigid. The woofer is protected by a metal grille. All controls and connectors are recessed on the rear. A 1-3/8" stand socket and M10 threaded inserts are molded into the cabinet to provide quick and easy installation using specially designed accessory mounting hardware.

■ This Mackie Industrial product is covered by an exclusive, one-time, NO FAULT repair policy in addition to a five year limited warranty.

Two-Way Speaker System



Features

- 80° x 75° constant-directivity horn with 1" exit compression driver
- 12" high-gauss woofer
- Compact, semi-trapezoidal lightweight polypropylene enclosure
- Built-in hand grip, M10 fly points and stand socket
- Optional installation accessories available
- Exclusive Mackie Industrial — one-time, NO FAULT repair policy
- Five year limited warranty

- Live Sound/Music Reinforcement
- High-Level AV Playback
- Large Speech Systems
- High-Level Passive Systems

ART300 Two-Way Speaker System

Specifications

System Acoustic

Frequency Range (-10 dB):	60Hz-19kHz
Frequency Response (-3 dB):	195Hz-17kHz
Horz. Coverage Angle (-6 dB):	80°, averaged 1kHz to 10kHz
Vert. Coverage Angle (-6 dB):	75°, averaged 1kHz to 10kHz
Directivity Factor; Q(DI):	10.0 (10), averaged 1kHz to 10kHz
System Sensitivity ¹ :	101dB 1W @ 1m
Rated Maximum Peak ² :	132dB @ 1m
System Input Power Rating ² :	300W, RMS; 1200W Peak
Recommended Amplifier ³ :	450W
System Nominal Impedance:	8Ω
HF Protection:	Dynamic
Crossover:	1.8kHz, 12dB/octave

Transducers

Low-Frequency:	12" (300mm) woofer with 3" (76mm) voice coil
High-Frequency:	Polynomial horn-loaded 1" (25mm) exit compression driver

Physical

Enclosure:	Gray, semi-trapezoidal, reinforced polypropylene
Mounting:	Four M10 metal threaded inserts, 1.375" (35mm) lockable stand mount
Grille:	Protective perforated steel grille with foam backing
Input Connectors:	2 x NL4 Speakon® connector plate
Dimensions (HxWxD):	24.42" x 15.36" x 12.29" (620mm x 390mm x 312mm)
Weight:	39.7lbs. (18kg)

Options

ART A-2	Wall mount bracket, black
ART A-5	Swivel, tilt, wall mount hardware, black
ART A-7	Full front metal grille, black
ART A-11	U-bracket, black

¹ Measured on axis in the far field with 1 watt (2.83 V RMS, 8Ω) input and referenced to 1 meter distance using the inverse square law. Listed sound pressure represents an average from 300Hz to 3kHz.

² RMS using 20Hz to 20kHz, PN Spectrum, Peak for 2 hours with +6 dB crest factor.

³ Recommended Amplifier is a power capability value that should be taken as a guide.

ART300 Two-Way Speaker System

ART300 Vertical Polars

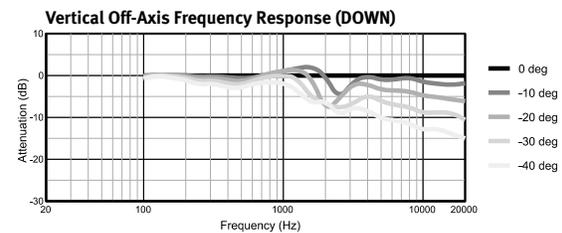
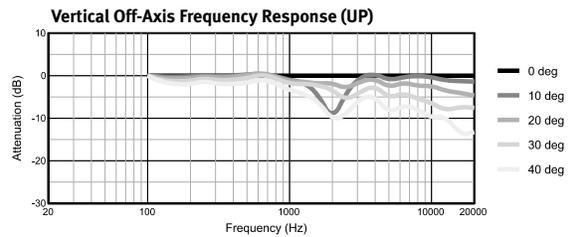
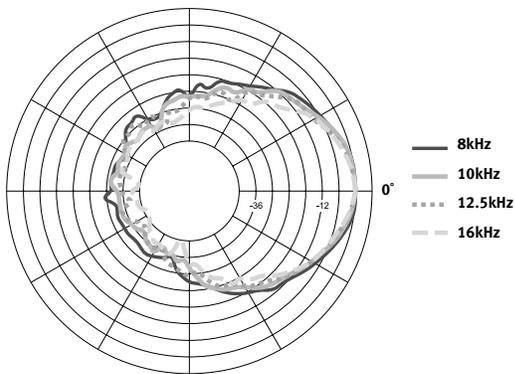
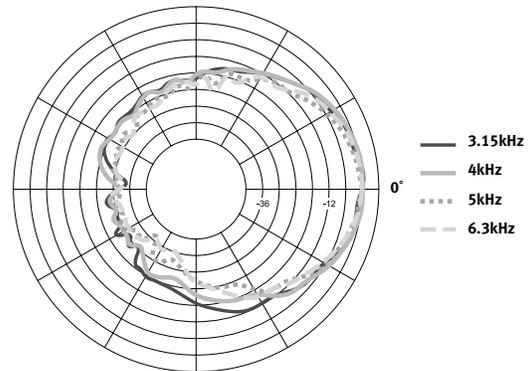
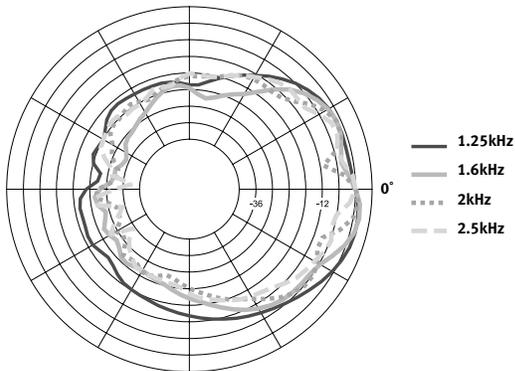
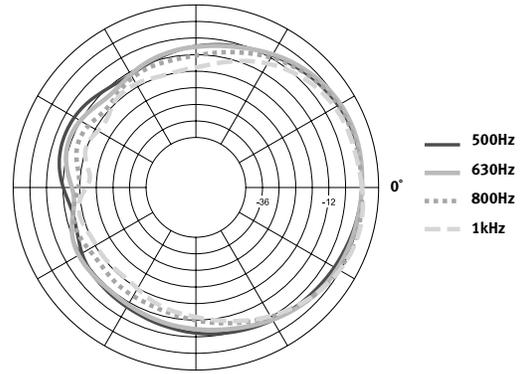
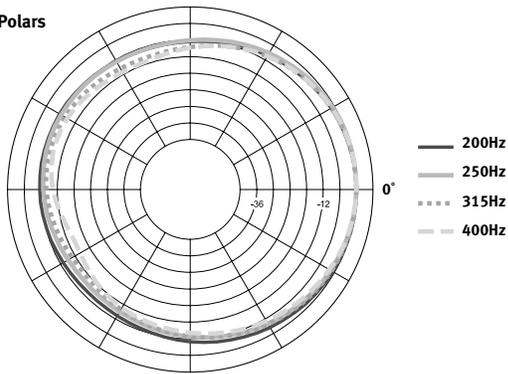

ART300
Horizontal Polars

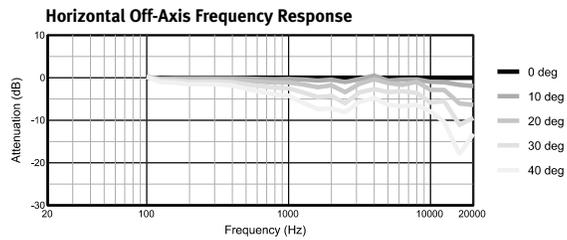
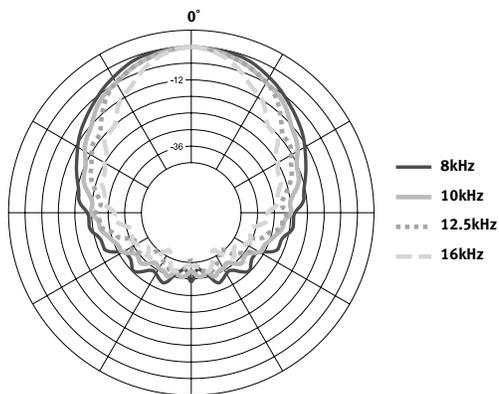
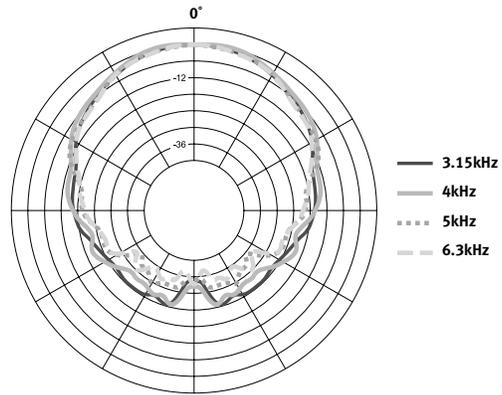
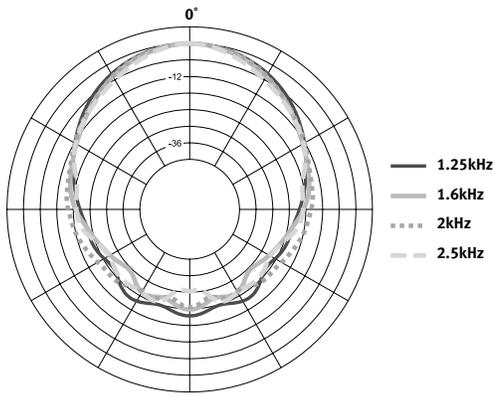
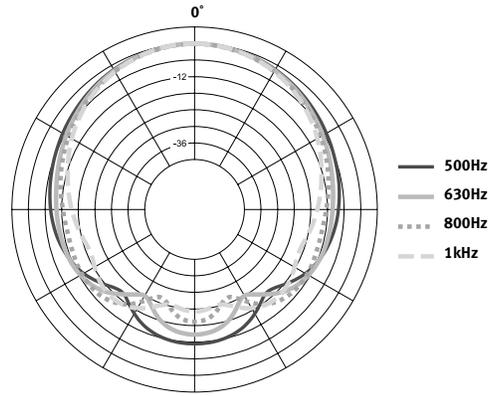
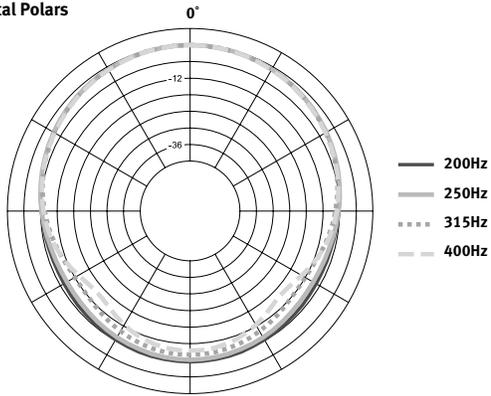

ART300 Two-Way Speaker System

Frequency response is measured on-axis at a distance referenced back to 1m at 1-watt drive. Shown as a half space (2π) environment.

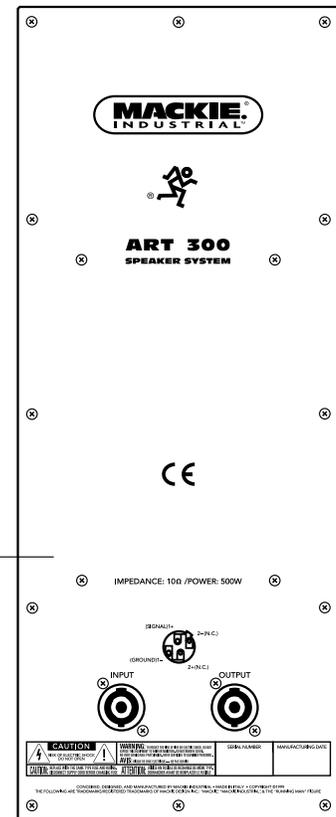
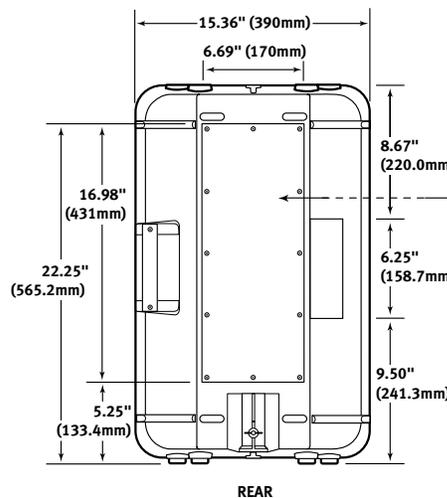
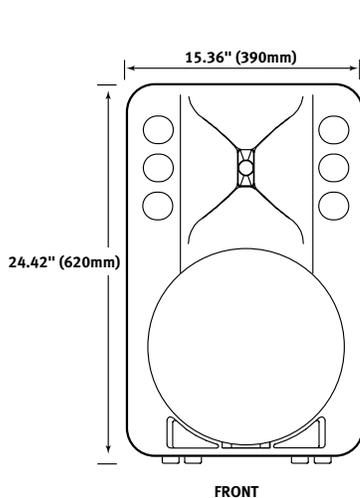
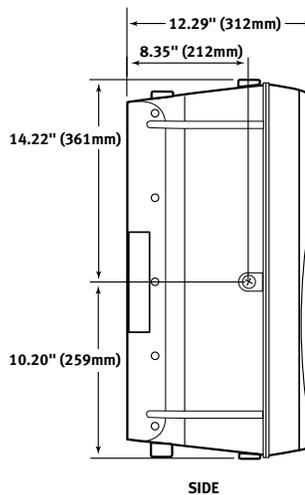
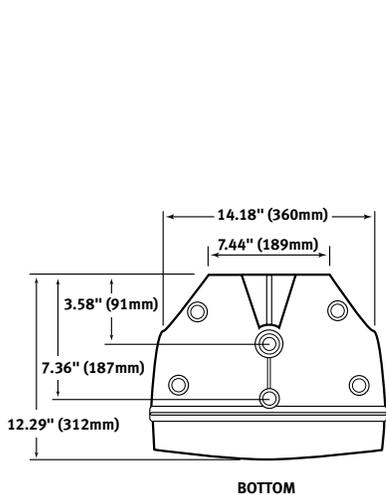
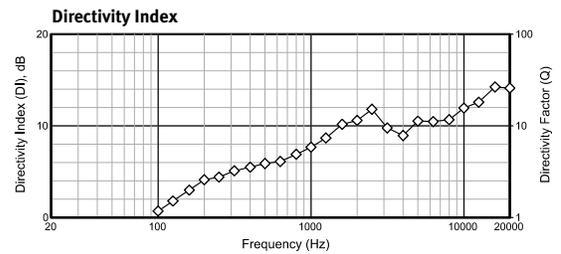
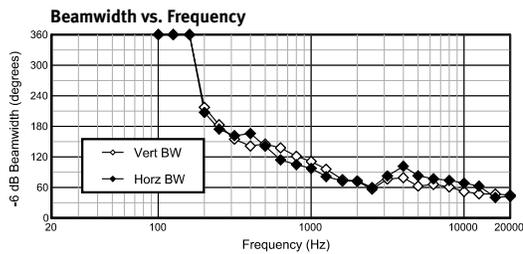
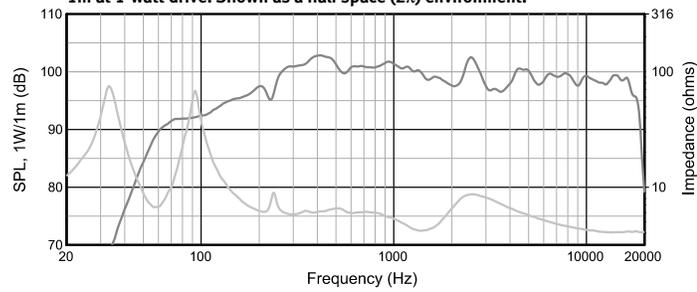

ART300 Two-Way Speaker System

Architects' and Engineers' Specifications

The loudspeaker shall be a self-contained unit, housed in a vented, reinforced polypropylene enclosure and consisting of: (1) a 12 inch low-frequency, cone driver, (2) a 80° x 75°, high-frequency, constant-directivity polynomial horn and horn-loaded, 1 inch compression driver, (3) passive crossover network.

The drivers shall be crossed over at 1.8kHz by a 2-pole, passive network that contains equalization for the constant directivity horn and shall present a nominal 8Ω load to the power amplifier. When measured (500Hz–16kHz) the directivity factor shall be at least 10.0. The loudspeaker shall be capable of operating continuously with a pink noise signal delivered at 300W RMS. It shall produce at least 101dB SPL (300Hz–3kHz) at 1m with an input of 1W RMS. Its peak power handling capability shall not be less than 1200W peak, producing 132dB SPL (1m, anechoic). The nominal frequency response of the system shall be 195Hz–17kHz ±3dB.

The reinforced polypropylene enclosure shall have a volume of at least 1.65 cu. ft., be trapezoidal shaped and equipped with a grille to protect the cone driver. Two Neutrik Speakon® connectors shall be provided for input and input loop-through. At least four M10 threaded sockets and a stand socket shall be molded into the cabinet for attaching mounting hardware, designed for the unit and available from the manufacturer. The loudspeaker system shall be a model ART300 manufactured by Mackie Industrial.



www.mackieindustrial.com

16220 Wood-Red Rd. NE, Woodinville, WA 98072 USA
888.337.7404, fax 425.487.4337, industrial@mackie.com

UK +44.1268.571.212, fax +44.1268.570.809, info@rcf-uk.com
ITALY +39.0522.354.111, fax +39.0522.926.208, industrial@rcf.it
FRANCE +33.3.8546.9160, fax +33.3.8546.9161, rcf.commercial@wanadoo.fr
GERMANY +49.2572.96042.0, fax +49.2572.96042.10, industrial@mackie.de

Electronic files for this product available at:
www.mackieindustrial.com

This Specification Sheet

ART300.PDF

Quick-Start Manual

ART300QS.PDF

Mackie Designs continually engages in research related to product improvement. New material, production methods, and design refinements are introduced into existing products without notice as a routine expression of that philosophy. For this reason, any current Mackie Industrial product may differ in some respect from its published description, but will always equal or exceed the original design specifications unless otherwise stated. ©1999-2001 Mackie Designs Inc. All rights Reserved. **MACKIE** and  are registered trademarks of Mackie Designs Inc. Mackie Industrial is a trademark of Mackie Designs Inc.

part no. 910-170-10 Rev.B