

α

---

**α**LPHA™  
DESKTOP RECORDING STUDIO

---



**COMPLETE RECORDING SOLUTION**

## WARRANTY

1. Please register your product online at [lexiconpro.com](http://lexiconpro.com). Proof-of-purchase is considered to be the responsibility of the consumer. A copy of the original purchase receipt must be provided for any warranty service.
2. Lexicon Professional warrants this product, when purchased new from an authorized U.S. Lexicon Professional dealer and used solely within the U.S., to be free from defects in materials and workmanship under normal use and service. This warranty is valid to the original purchaser only and is non-transferable.
3. Lexicon Professional's liability under this warranty is limited to repairing or, at our discretion, replacing defective materials that show evidence of defect, provided the product is returned to Lexicon Professional **WITH RETURN AUTHORIZATION** from the factory, where all parts and labor will be covered up to a period of 1 year. A Return Authorization Number must first be obtained from Lexicon Professional. The company shall not be liable for any consequential damage as a result of the product's use in any circuit or assembly.
4. Lexicon Professional reserves the right to make changes in design or make additions to or improvements upon this product without incurring any obligation to install the same additions or improvements on products previously manufactured.
5. The foregoing is in lieu of all other warranties, expressed or implied, and Lexicon Professional neither assumes nor authorizes any person to assume on its behalf any obligation or liability in connection with the sale of this product. In no event shall Lexicon Professional or its dealers be liable for special or consequential damages or from any delay in the performance of this warranty due to causes beyond their control.

## TECHNICAL SUPPORT & SERVICE

If you require technical support, contact Lexicon Professional Technical Support. Be prepared to accurately describe the problem. Know the serial number of your device – this is printed on a sticker attached to the chassis.

Before you return a product to the factory for service, we recommend you refer to this manual. Make sure you have correctly followed installation steps and operating procedures. For further technical assistance or service, please contact our Technical Support Department at (801) 566-8800 or visit [lexiconpro.com](http://lexiconpro.com). If you need to return a product to the factory for service, you **MUST** first contact Technical Support to obtain a Return Authorization Number.

### **NO RETURNED PRODUCTS WILL BE ACCEPTED AT THE FACTORY WITHOUT A RETURN AUTHORIZATION NUMBER.**

Please refer to the Warranty information, which extends to the first end-user. After expiration of the warranty, a reasonable charge will be made for parts, labor, and packing if you choose to use the factory service facility. In all cases, you are responsible for transportation charges to the factory. If the product is still under warranty, Lexicon Professional will pay the return shipping.

Use the original packing material if it is available. Mark the package with the name of the shipper and with these words in red: DELICATE INSTRUMENT, FRAGILE! Insure the package properly. Ship prepaid, not collect. Do not ship parcel post.

## TABLE OF CONTENTS

<b>INTRODUCTION</b> .....	<b>1</b>	<b>USING THE ALPHA STUDIO</b> .....	<b>11</b>
<b>FEATURES</b> .....	<b>1</b>	<b>Recording With The Alpha Studio</b> .....	<b>11</b>
<b>UNPACKING THE ALPHA STUDIO</b> .....	<b>2</b>	A. Recording Using The Mic or Line Inputs .....	11
<b>COMPUTER MINIMUM REQUIREMENTS</b> ..	<b>2</b>	B. Recording A Guitar Using The Instrument Input ..	12
<b>THE FRONT PANEL</b> .....	<b>3</b>	C. Recording With Cubase LE .....	13
1/4" Instrument Input Jack .....	3	D. Setting Monitor Levels .....	18
Line 1/Inst .....	3	E. Using Software Input Monitoring .....	19
Peak LEDs .....	3	<b>Adjusting The Buffer Settings</b> .....	<b>21</b>
Line 2/Mic .....	3	Adjusting The Buffers In Windows .....	21
Monitor Assign .....	3	Adjusting The Buffers In Mac OS X .....	22
Monitor Mix .....	3	<b>SPECIFICATIONS</b> .....	<b>23</b>
USB LED .....	4	<b>SIGNAL ROUTING DIAGRAM</b> .....	<b>24</b>
Output Level .....	4		
1/8" Headphone Output Jack .....	4		
<b>THE REAR PANEL</b> .....	<b>5</b>		
USB Port .....	5		
Line In 1-2 .....	5		
Mic Input .....	5		
1/4" Left/Right Line Outputs .....	5		
RCA Left/Right Line Outputs .....	5		
<b>CONNECTING TO THE ALPHA STUDIO</b> ...	<b>6</b>		
<b>Monitoring Connections</b> .....	<b>6</b>		
Connecting Headphones .....	6		
Connecting To Monitor Speakers .....	6		
Connecting RCA Outputs To A Home Stereo .....	6		
<b>Recording Connections</b> .....	<b>7</b>		
Connecting A Microphone .....	7		
Connecting A Line-Level Source .....	7		
Connecting An Instrument .....	7		
<b>Mixdown Connections</b> .....	<b>8</b>		
Connecting To An External Recorder .....	8		
Mixing Within Cubase® LE .....	8		
<b>Connection Diagram</b> .....	<b>9</b>		
<b>SOFTWARE SETUP</b> .....	<b>10</b>		
Windows® .....	10		
Mac® .....	10		

## INTRODUCTION

Congratulations on your purchase of the Lexicon® Alpha Desktop Recording Studio™.

The Alpha Studio™ is a complete package of hardware and software that turns your USB-equipped computer into a professional multitrack recording workstation. Whether you use it for high-quality stereo location recording with a laptop computer, or for multitrack overdubbing and mixing in a home studio desktop system, the Alpha Studio hardware provides the professional-quality inputs and outputs, metering, and level controls that computer sound cards or built-in audio connections lack.

So you can make full use of the Alpha Studio right away, we've included the popular Steinberg® Cubase® LE production suite software for PC and Mac® computers. Cubase LE offers integrated multitrack audio and MIDI recording, editing, and mixing, VST® Instrument support, VST plug-in effects support, and an array of additional features.

The included Lexicon reverb plug-in is also a major feature of the Alpha Studio package, providing the lush Lexicon reverbs that have been used on professional recordings for over thirty years. Alternatively, the Lexicon Alpha Studio may be used as an interface with almost any other major audio recording software you may have, such as Steinberg Cubase®, Ableton™ Live, MOTU® Digital Performer®, GarageBand®, Cakewalk® Sonar™, Logic®, Pro Tools®, and many others.

## FEATURES

- 4 analog audio inputs
  - 1 - XLR mic input with low-noise preamp and 50 dB gain
  - 2 - ¼" analog RF filtered TRS active-balanced line inputs
  - 1 - ¼" high-impedance analog instrument input
- 2 - RCA outputs
- 2 - ¼" analog TRS active line outputs
- High powered headphone amplifier
- 24-bit A/D and D/A converters, supporting sample rates of 44.1 kHz and 48 kHz
- Zero-latency analog record monitoring with adjustable balance between Direct and Playback Signals
- Stereo and Mono input source monitoring
- 100% USB Powered

## **UNPACKING THE ALPHA STUDIO**

Thoroughly inspect the Alpha Studio and packing materials for signs of damage. Report any shipping damage to the carrier that delivered the product or dealer from whom you purchased the product at once.

## **COMPUTER MINIMUM REQUIREMENTS**

The Lexicon Alpha doesn't require an extremely powerful computer to use. However, once you start playing multiple tracks, applying processing to these tracks with plug-ins, and utilizing the other processing features available in your recording software, more computing resources are required.

Powerful software for audio recording requires a powerful computer with the right operating system software, processor, memory, and hard drive space. Most computers currently sold already meet these requirements, or can be upgraded to meet these requirements. As with all such systems, adding more RAM than the minimum will allow you to do more processing and improve performance, and more disk space will give you more storage for your audio files.

For the latest Alpha Studio and included Lexicon reverb plug-in system requirements, visit <http://lexiconpro.com/en-US/products/alpha>.

For the latest Steinberg Cubase LE requirements, visit [https://www.steinberg.net/en/products/cubase/specs\\_downloads.html](https://www.steinberg.net/en/products/cubase/specs_downloads.html).

## THE FRONT PANEL

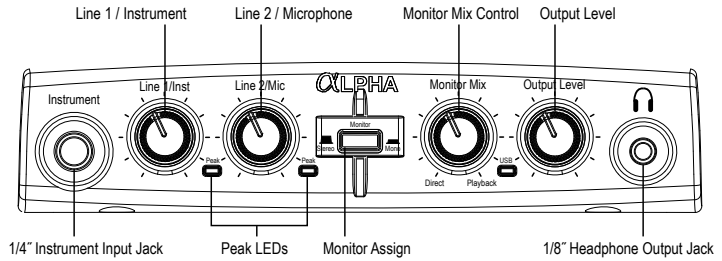

### 1/4" INSTRUMENT INPUT JACK

This 1/4" jack accepts unbalanced, low-level, high-impedance instrument sources such as electric guitar, acoustic guitar with a pickup, or electric bass. The input gain is adjusted using the **Line 1/Inst** knob on the front panel. When an instrument is plugged into this input, it disables the **Line 1** audio input on the rear panel.

### LINE 1/INST

This knob adjusts the Line 1 and Instrument Input gain.

### PEAK LEDs

These LEDs light when the input signal is within 5 dB of analog clipping. If the Peak LEDs flicker occasionally, the signal is approaching clipping levels, but this does not necessarily indicate distortion or actual clipping.

### LINE 2/MIC

This knob adjusts the Line 2 and Mic Input gain.

### MONITOR ASSIGN

This button selects whether a pair of analog audio sources will be heard in stereo or mono in the Direct Monitor Mix. In Stereo mode, the left inputs (Line 1/Inst) are routed to the left channel and right inputs (Line 2/Mic) are routed to the right channel.

In Mono mode, you'll hear all inputs in the center of the Direct Monitor Mix through the Headphone or Line outputs.

When the Monitor switch is in Mono, it does not change the signals going to the computer in any way — they will still be separate and stereo in the computer.

### MONITOR MIX

The Alpha Studio gives you the ability to hear your analog input signals directly and immediately while recording, without having to adjust levels in software, and before the delay caused by digital converters and computer recording latency. This zero-latency analog monitoring is controlled by the **Monitor Mix** knob, which you can use to adjust the blend between the Alpha Studio's live analog inputs (called "Direct")

For the cleanest recording, adjust the Gain so the Peak LED flashes only occasionally, on the loudest part of the performance.

DO NOT TURN DOWN A Gain CONTROL TO GET THE RIGHT MIX IN YOUR HEADPHONES OR MONITORS WHILE RECORDING. USE THE **Monitor Mix** CONTROL FOR THIS PURPOSE.

and any audio coming back from the computer via USB (“Playback”). To adjust the playback mix coming back from the computer (previous tracks, effect returns, etc.), use the faders on the Mixer screen of the recording software. To hear only the live source input signals plugged into the Alpha Studio, turn the **Monitor Mix** knob fully left to **Direct**. To hear only the mix from the computer, turn the **Monitor Mix** knob fully right to **Playback**. The output from the Monitor Mix control is routed directly to the Line and Headphone outputs. This ability to easily control the relative levels of computer audio playback and latency-free live analog inputs is very useful when overdubbing.

### **USB LED**

When the blue **USB LED** is on, it indicates the Alpha Studio is being powered by your computer and audio signals can pass in and out of the system.

### **OUTPUT LEVEL**

This knob controls the overall output level of the Alpha Studio’s Line and Headphone outputs.

### **1/8" HEADPHONE OUTPUT JACK**

The high-powered Headphone output accommodates stereo headphones with an 1/8" stereo plug.

## THE REAR PANEL

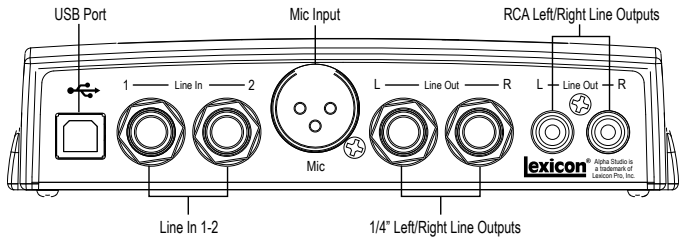

### USB PORT

The USB Port is used to connect the Alpha Studio to your computer and provides the Alpha Studio hardware with power. A standard USB cable is included. The Alpha Studio supports USB 2.0 full speed.

### LINE IN 1-2

These 1/4" inputs can accept both balanced (3-conductor TRS) and unbalanced (2-conductor TS) line level audio sources. The input gain is adjusted using the **Line 1/Inst** and **Line2/Mic** gain knobs on the front panel.

**NOTE:** When a cable is connected to the **Instrument** input on the front panel, the **Line 1** input is disabled. When a cable is connected to the **Line 2** input, the **Mic** input is disabled.

### MIC INPUT

This balanced XLR input features a high-quality mic preamp designed specifically for low-impedance professional dynamic and self-powered condenser microphones. The input gain is adjusted using the **Line 2/Mic** gain knob on the front panel, with 50 dB of gain at the maximum setting.

### 1/4" LEFT/RIGHT LINE OUTPUTS

These outputs support balanced TRS or unbalanced TS 1/4" connections. These outputs can be connected to a mixing board, power amplifier, powered studio monitors, recorder, or another line-level input.

### RCA LEFT/RIGHT LINE OUTPUTS

These outputs support RCA connections. These outputs can be connected to a mixing board, power amplifier, powered studio monitors, recorder, or another line level input.



## CONNECTING TO THE ALPHA STUDIO

The Alpha Studio is both a 2 x 2 x 2 mixer and a USB audio interface that can be used in a variety of audio applications. This section describes how to make basic connections for the following functionality:

- Monitoring Audio
- Recording Audio
- Connecting a Recorder for Mixdown

### MONITORING CONNECTIONS

The Alpha Studio allows you to monitor audio from both the hardware inputs (Direct) and from the computer (Playback). Use the **Monitor Mix** control to balance between the direct audio and playback audio from your computer. For a complete description of the Monitor Mix control, see "*Monitor Mix*" on page 3.

You can monitor the audio through the 1/8" Headphone jack on the front panel, through studio monitors using the 1/4" or RCA L/R Line Out jacks on the rear panel, or both. The output level of both the L/R Line Out jacks and the Headphone jack are controlled with the **Output Level** knob on the front panel.

The Alpha Studio's 1/4" L/R Line Outputs have a nominal output of +4 dBu, and support both balanced (TRS) or unbalanced (TS) connections.

### CONNECTING HEADPHONES

1. Connect headphones to the **Headphone** jack located on the front panel of the Alpha Studio. The Headphone jack accepts an 1/8" TRS connector.
2. Adjust headphone volume with the **Output Level** knob.

### CONNECTING TO MONITOR SPEAKERS

1. Using 1/4" cables (balanced TRS cables are recommended), connect the **L/R Line Out** jacks on the rear panel of the Alpha Studio to the appropriate inputs on your mixer, power amp, or powered speakers.
2. Adjust the Alpha Studio's output volume with the **Output Level** knob. If using both headphones and monitor speakers, adjust the level of the external power amp or speakers using their gain controls after you've set the desired level in your headphones.

### CONNECTING RCA OUTPUTS TO A HOME STEREO

Connect the **RCA Line Out 1-2** jacks on the rear panel of the Alpha Studio to the appropriate inputs on your stereo, typically the Tape In or Aux In jacks, using standard RCA cables. Keep the **Output Level** knob on the Alpha Studio low at first, raising it slowly to match the level of other units connected to the stereo.

For the cleanest recording, adjust the Gain so the Peak LED flashes only occasionally, on the loudest part of the performance.

DO NOT TURN DOWN A Gain CONTROL TO GET THE RIGHT MIX IN YOUR HEADPHONES OR MONITORS WHILE RECORDING. USE THE **Monitor Mix** CONTROL FOR THIS PURPOSE.

## RECORDING CONNECTIONS

Analog audio signals are created by microphones, synthesizers, mixers, and instruments with magnetic pickups. Of these sources, microphones and magnetic instrument pickups have the lowest output level, and generally require the most amplification. Keyboards, preamps, and mixers output “line-level” audio, which varies with each device between the -10 dBV and +4 dBu standards.

### CONNECTING A MICROPHONE

Plug an XLR cable directly from a microphone into the **Mic** input on the Alpha Studio rear panel. Only dynamic (non-powered) or self-powered condenser mics are accepted.

**NOTE:** When using the **Mic** input, DO NOT plug a cable into the **Line In 2** input. Inserting a cable into the **Line In 2** input disconnects the **Mic** input internally.

### CONNECTING A LINE-LEVEL SOURCE

Plug a ¼" TS (unbalanced) or TRS (balanced) cable directly from the line-level source into the desired **Line In** jack on the rear panel of Alpha Studio. Line-level sources include keyboards, drum machines, CD and cassette players, and external microphone preamps and effects. If the line-level source has something other than ¼" outputs, cable adapters can be used.

**NOTE:** When using the **Line In 1** input, DO NOT plug a cable into the **Instrument** input. Inserting a cable into the **Instrument** input disconnects the **Line In 1** input internally.

### CONNECTING AN INSTRUMENT

Plug a standard ¼" TS (instrument) cable directly from the instrument into the **Instrument** input jack on the front panel of Alpha Studio. Note that this will disable the **Line In 1** jack on the back panel.

### MIXDOWN CONNECTIONS

After you record and mix your sessions in either Cubase® LE or other recording software, you may want to mix them down to a DAT, tape recorder, CD recorder, or other stereo 2-track recording device.

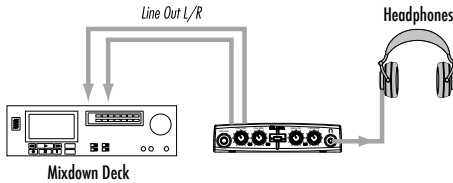

### CONNECTING TO AN EXTERNAL RECORDER

Connect either the RCA or ¼" **Line Out L-R** jacks on the back of the Alpha Studio to the left and right recorder inputs respectively. Refer to your recorder's operator's manual for more information about setting recording levels.

If you are connecting to an analog mixdown deck (such as a tape machine), start with the **Output Level** knob on the Alpha Studio at about the 12 o'clock position, and the recorder's input level also at or near 12 o'clock. Adjust the **Output Level** knob on the Alpha Studio until the meters on your recording deck read consistently between 0 dB to +4 dB, raising the input level control on the recorder if necessary.

If you are connecting to a digital recorder, such as a DAT or CD recorder, set the input level(s) on the recording device all the way open, to their maximum setting, and then adjust the **Output Level** knob on the Alpha Studio until the meters on your recording deck device consistently peak just below the 0 dBFS (Full Scale) mark without causing clipping (going over the 0 dBFS mark). As a general rule of thumb, the loudest peaks in the audio material should peak at around -6 dBFS on the recorder's input meter(s).

To hear the mix through studio monitor speakers, connect the outputs of the 2-track recording deck to the inputs of the amplifier or powered speakers. Adjust the monitoring level using the output level of the recording deck or the input level of the amplifier or powered speakers.

### MIXING WITHIN CUBASE® LE

You can mixdown directly within Cubase LE or other recording software, and burn an audio CD from that mix (provided your computer has a CD-R drive). Consult the Cubase LE manual or documentation for your recording software for a complete description of mixing within the software.

### CONNECTION DIAGRAM

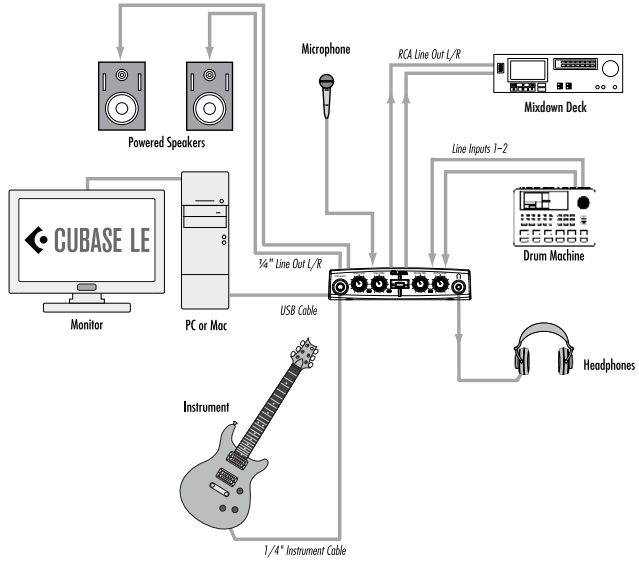

## SOFTWARE SETUP

### WINDOWS®

If you haven't already installed the Windows USB driver, Cubase LE, and included Lexicon® reverb plug-in software, please do so before continuing on to the next section. Consult the Software Installation Guide available at <http://lexiconpro.com/en-US/products/alpha#documentation> to ensure successful installation of these software programs.

**NOTE:** You must install the USB driver after you've made the connection between your computer's USB port and the USB port of the Alpha Studio.

### MAC®

If you haven't already installed the Cubase LE and included Lexicon® reverb plug-in software, please do so before continuing on to the next section. Consult the Software Installation Guide available at <http://lexiconpro.com/en-US/products/alpha#documentation> to ensure successful installation of these software programs.

**NOTE:** A USB device must initialize itself with the host computer to operate correctly. The simplest way to avoid problems is to connect the Alpha Studio to the USB port after the computer is booted.

## USING THE ALPHA STUDIO

### RECORDING WITH THE ALPHA STUDIO

#### A. RECORDING USING THE MIC OR LINE INPUTS

This section explains how to record using the **Mic** or **Line** inputs on the back of the Alpha Studio. The diagram below shows how the Alpha Studio is connected for this particular application.

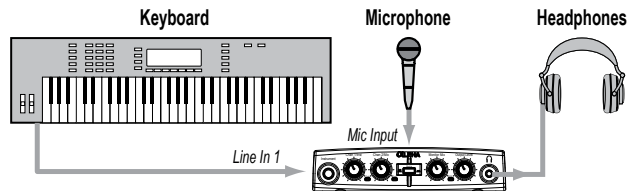

Turn down all of the Alpha Studio's input and output level controls. Plug your microphone cable into the **Mic Input** XLR jack or line-level audio source to the **Line 1** ¼" jack on the back of the Alpha Studio.

**NOTE:** When using the **Mic** input, DO NOT plug a cable into the **Line In 2** jack. Inserting a cable into the **Line In 2** jack disconnects the **Mic** input internally.

To set the input level for the Mic or Line input:

1. If you're recording a mic and the Alpha Studio is connected to studio monitors in the same room, turn them off to avoid bleed and feedback and use headphones.
2. Set the **Output Level** knob to the 9 o'clock position.
3. Set the **Monitor Mix** knob to the 12 o'clock position. Press the **Monitor Assign** button so it is in the **Mono** position. This will let you hear output on both sides of your headphones when recording only one microphone or line-level signal.

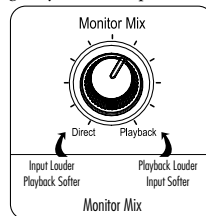
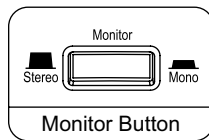

4. While playing the line-level instrument or speaking/singing into the microphone, gradually increase the corresponding gain by turning up the **Line 1/Inst** or **Line 2/Mic** knob until the **Peak** LED next to the knob just begins to light occasionally. Re-adjust the **Output Level** knob for the desired monitoring level.
5. For instructions on recording in Cubase LE, go to "C. Recording With Cubase LE" on page 13.

### B. RECORDING A GUITAR USING THE INSTRUMENT INPUT

This section explains how to record using the 1/4" **Instrument** input jack on the front panel. The diagram below shows how the Alpha Studio is connected for this particular application.

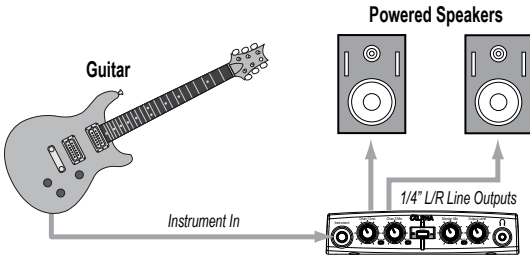

Turn down all of the Alpha Studio's input and output level controls. Plug your electric, acoustic, or bass guitar into the **Instrument** input jack on the front of the Alpha Studio hardware.

The **Instrument** input uses the same recording channel as the **Line 1** input; anything plugged into the 1/4" **Line 1** input jack on the back of the Alpha Studio will not be recorded when a cable is connected to the 1/4" **Instrument** input jack on the front panel.

**NOTE:** This jack is intended for electric guitar and bass, or acoustic instrument pickups, not line-level signals such as the output of keyboards or a direct out from a guitar amplifier. For those, use the **Line 1-2** input jacks on the back of the Alpha Studio hardware.

#### To set the input level for the Instrument input:

1. Set the **Output Level** knob to the 9 o'clock position.
2. Set the **Monitor Mix** knob to the 12 o'clock position. Press the **Monitor Assign** button so it is in the **Mono** position. This will let you hear the mono guitar signal out of both speakers.

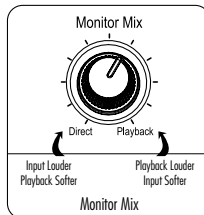
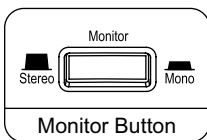

3. While playing the guitar, gradually increase the gain by turning up the **Line 1/Inst** knob until the **Peak** LED next to the knob just begins to light occasionally. Re-adjust the **Output Level** knob for the desired monitoring level.
4. For instructions on recording in Cubase LE, go to "*C. Recording With Cubase LE*" on page 13.

### C. RECORDING WITH CUBASE LE

To create a new session and prepare Cubase LE to record:

1. Open Cubase LE.
2. To create a new empty recording session, select the **Prompt for project location** option. Select **More>Empty**, then click the **Create** button.



3. Select the location on the hard drive where you would like to create the new project; create a new folder if necessary. When done, click the **Open** button (or **OK** button if using Windows).

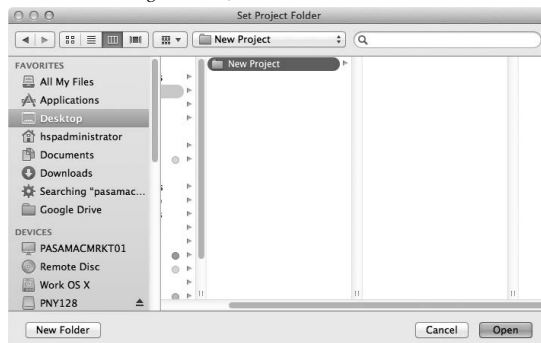



- Go to the **Devices** menu and select the **Device Setup** option.



- Click on **VST Audio System** and, if not already selected, select **Alpha ASIO** (for Windows) or **Lexicon Alpha In/Out** (for Mac). Click the **Switch** button to select the driver, then click **OK**. You are now ready to begin recording using your Alpha Studio and Cubase LE.

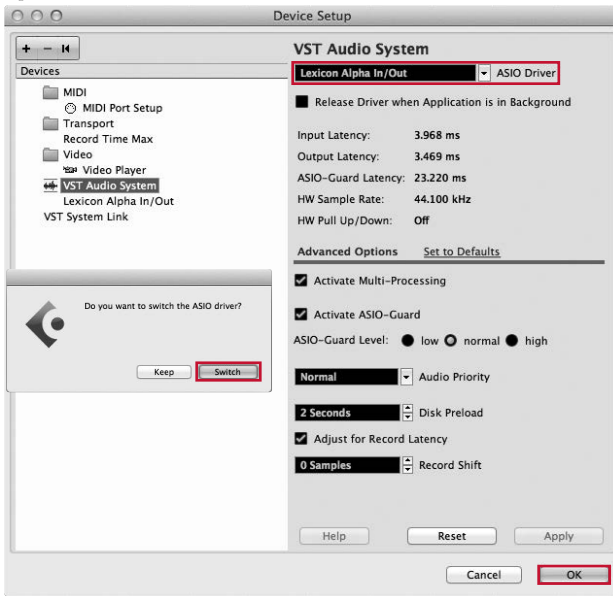

To create an audio track and assign an audio input:

1. Click the **Project** menu and select **Add Track>Audio**.

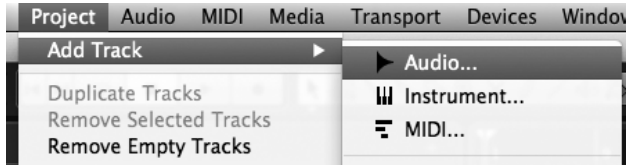

2. When the **Add Audio Track** dialog appears, select the **Mono** configuration, name the track, then click the **Add Track** button.

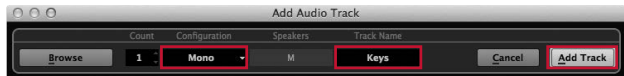

3. Make sure the **Inspector** window is enabled, located in the upper-left corner of the screen. The **Inspector** window is displayed on the left side of the screen.

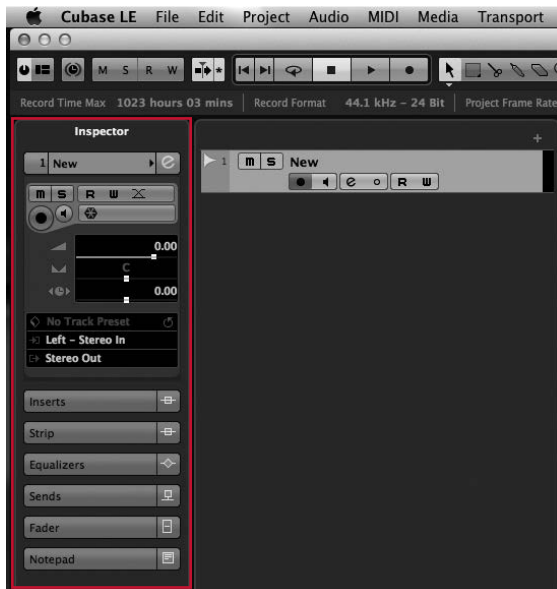

- In the **Inspector** window, select the input you would like to record by clicking the **Input Routing** field then selecting the track input source. Select "**Stereo In - Left**" to record from the **Line 1/Instrument** input or "**Stereo In - Right**" to record from the **Line 2/Mic** input.

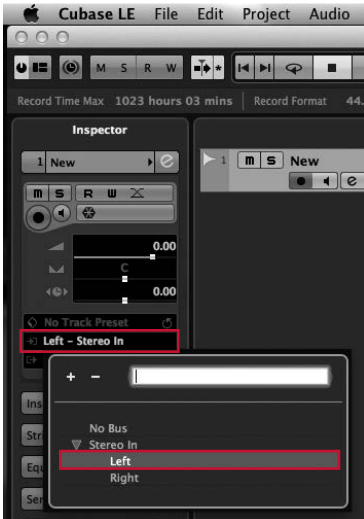

- In the **Track** window, the **Record Enable** button should already be red. If it isn't, click it so that it turns red.

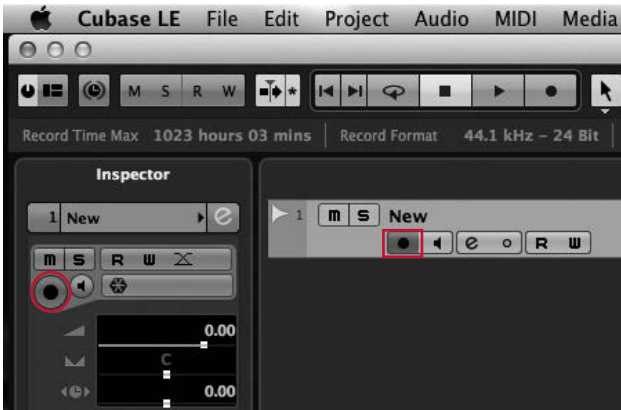

6. In the **Track** window, make sure the **Input Monitor** button is not lit.

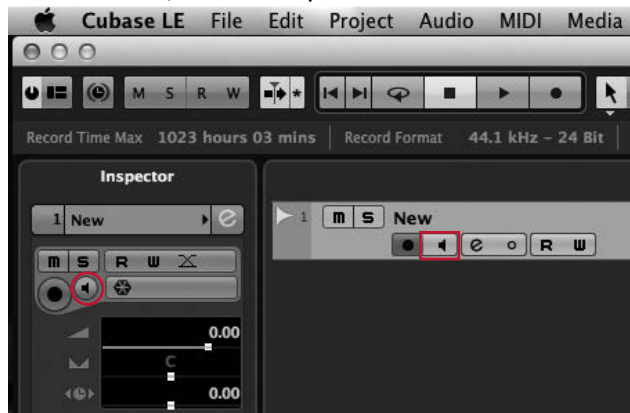

To start recording:

1. Click the **Record** button on Cubase® LE's Transport control.

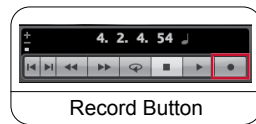

Record Button

2. Speak, sing, or play the instrument.  
3. When you are finished recording, press the **Stop** button.



Stop Button

4. Press the **Zero** button to return to the beginning of the session then press the **Play** button to listen to the track you just recorded.



Zero and Play Buttons

**NOTE:** Make sure the **Monitor Mix** knob is set to the 12 o'clock position then turn the **Output Level** knob to adjust the monitoring level. See "D. Setting Monitor Levels" on page 18 for more information.

- To overdub a track, create a new track as previously described then make sure the record button on the new track is enabled and any previously recorded tracks are **not** record enabled. This will allow you to record to the new track without affecting the previously recorded tracks.



### D. SETTING MONITOR LEVELS

To set monitor levels for a comfortable listening level:

- While playing back the recording, adjust the **Monitor Mix** knob to balance the levels between the direct input signal and recording playback. To make the direct input louder than the recording playback in the headphones or speakers, turn the **Monitor Mix** knob towards the **Direct** side. To make the recorded track(s) louder, turn the **Monitor Mix** knob towards the **Playback** side.

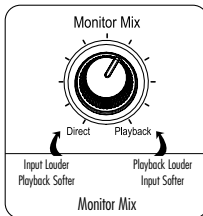

**NOTE:** Changing the **Monitor Mix** does not affect the recording level, only what you hear while recording. You can also adjust the playback level and pan position of the original track in your monitor by adjusting the controls for the track within Cubase® LE's Mixer window.

- Adjust the **Output Level** knob to control the overall monitoring level.

## E. USING SOFTWARE INPUT MONITORING

The previous examples have had Cubase LE's input monitoring turned off while recording tracks and used the **Monitor Mix** knob on the front of the Alpha Studio hardware to directly monitor an input without latency.

Software input monitoring lets you listen to software-based effects in real time and adjust the headphone/monitor mix independently of the recording levels. For example, software input monitoring can be used to apply reverb to vocals for the headphone mix, or monitor a direct bass or guitar performance through a bass/guitar amp simulator plug-in.

Keep in mind that when using software input monitoring there will be some latency (delay) introduced, which can make it difficult for a performer to play on time (this is especially true when recording percussive instruments and vocals). The amount of latency depends on the speed of your computer and the amount of buffers assigned in the ASIO control panel. See "*Adjusting The Buffer Settings*" on page 21 for more information on adjusting buffer settings.

To use software input monitoring:

1. When using Cubase LE's input monitoring with the Alpha Studio, you will usually want to set the **Monitor Mix** knob all the way to the **Playback** side so that you don't mix the direct and software monitored signals and introduce phasing artifacts.

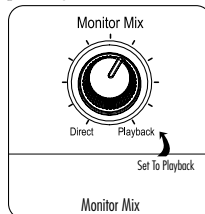

2. Click the **Input Monitor** button on the track you are recording to. You will now hear the input signal.

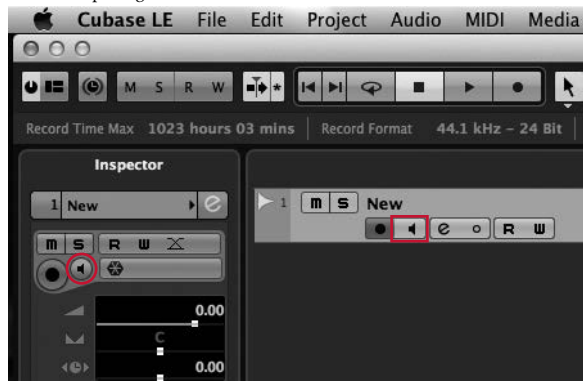

3. To assign an effect to the input, click the **Edit Channel Settings** button.

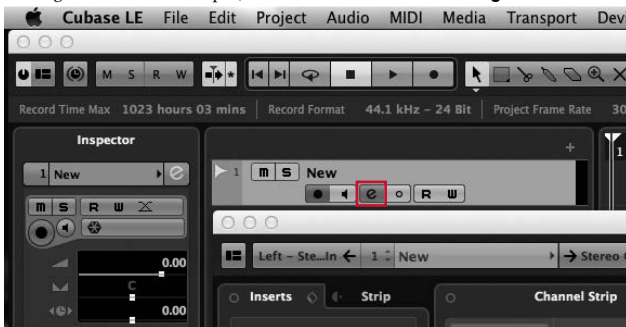

4. Left click on an **Insert** slot and select a plug-in from the list. If using a plug-in that offers a mix control, such as a reverb or delay, adjust the **Mix** control to change the ratio of dry (unprocessed) to wet (processed) sound. You're now ready to begin recording.



**NOTE:** Plug-ins inserted on a Cubase LE track are non-destructive, meaning they will not be recorded to the track. Such effects will, however, be audible during recording and playback and can be changed at any time to alter the effect.

## ADJUSTING THE BUFFER SETTINGS

Audio latency is the minimum time required for a computer to store recorded audio from an audio interface into the recording application memory and playback that same recorded audio back out of the audio interface output.

After the audio has been converted to the digital domain, it is passed to a buffer before it is processed by the driver and then passed to the audio application. An audio buffer is a reserved segment of memory used to hold this audio data to compensate for momentary delays in processing. The size of an audio buffer is the maximum number of samples the buffer can hold. For sound coming from the computer, there is an output buffer before the digital to analog conversion. "Buffering" introduces latency, since a buffer needs to fill up by a certain amount before the data can continue along the chain.

The buffers in Cubase® LE were automatically set at a safe setting for your computer when you installed the software. If you are using Cubase LE's input monitoring, you may wish to reduce the buffer size to reduce latency. Lowering the buffer size will lower the amount of latency when using input monitoring. Setting the buffers too low will result in unwanted digital artifacts, such as popping or crackling and possibly audio dropout. The faster the computer (Hard Disk and CPU), the lower you will be able to adjust the buffer setting without negatively impacting the audio. For more information, consult the Cubase LE documentation.

## ADJUSTING THE BUFFERS IN WINDOWS

1. Open Cubase LE and go to **Devices>Device Setup**.
2. Click on **VST Multitrack**.
3. Click the **Control Panel** button. You will now see the ASIO control panel. Moving the **Audio Buffering** slider toward Low Latency will decrease any monitoring latency. If audio playback has artifacts (clicking, popping), move this slider further toward the High Stability side.



4. When you are finished, click the **OK** button and return to your project to test the results.
5. Repeat this process as many times as necessary until you find a buffer setting that provides the lowest possible latency without digital artifacts.



**ADJUSTING THE BUFFERS IN MAC OS X**

1. Open Cubase LE and go to **Devices>Device Setup**.
2. Click on **Lexicon Alpha In/Out**.
3. Click on the **Control Panel** button. You can now select the buffer size. Selecting lower settings will decrease any monitoring latency. If audio playback has artifacts (clicking, popping), increase the setting slightly.

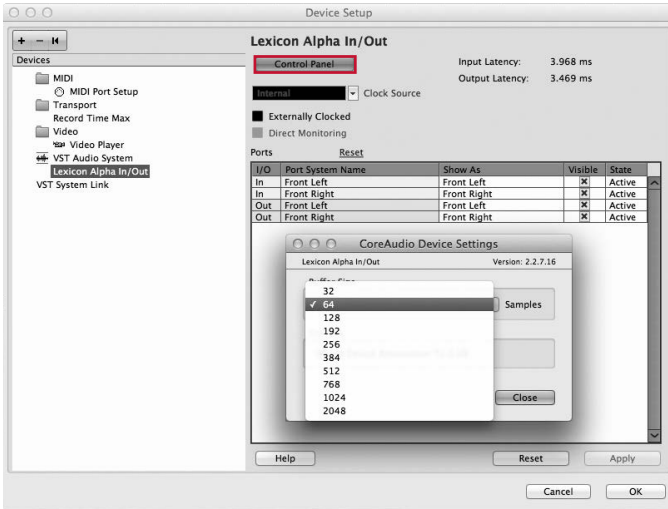

4. When you are finished, click **Close**, then **OK** and return to your project to test the results.
5. Repeat this process as many times as necessary until you find a buffer setting that provides the lowest possible latency without digital artifacts.

## SPECIFICATIONS

Microphone Input:	Female XLR Pin 2 Hot
Input Impedance:	600 Ohms balanced
GAIN:	+50 dB
EIN:	-115 dB A-weighted @ +50 dB gain (150 Ohm source impedance)
Maximum Input Level:	-7 dBu
Frequency Response:	+0, -0.5 dB 20 Hz - 20 kHz, ref. 1 kHz
THD+N:	<.005%, 20 Hz - 20 kHz
Line Inputs:	(2) 1/4" TRS balanced or unbalanced
Input Impedance:	20 kOhm balanced, 10 kOhm unbalanced
Maximum Input Level:	+13 dBu
Frequency Response:	+0, -0.5 dB 20 Hz - 20 kHz, ref. 1kHz
THD+N:	<.009% A/D, 20 Hz - 20 kHz
Instrument Input:	(1) 1/4" mono jack
Input Impedance:	1 MOhm unbalanced
Maximum Input Level:	+8.5 dBu
Frequency Response:	+0, -1 dB 20 Hz - 20 kHz, ref. 1 kHz
THD+N:	<.0125% A/D
Line Outputs:	(2) 1/4" TRS balanced or unbalanced
Level:	+16 dBu maximum
Impedance:	1 KOhm Balanced, 500 Ohm Unbalanced
Headphone Output:	(1) 1/8" stereo jack 20 mW per channel at 50 Ohms
Sample Rate:	44.1 kHz or 48 kHz (determined by computer application)
Dynamic Range:	A/D (24 Bit) 100 dB typical, A-weighted, 20 Hz - 20 kHz D/A (24 Bit) 100 dB typical, A-weighted, 20 Hz - 20 kHz
A/D/A (24 Bit)	97 dB typical, A-weighted, 20 Hz - 20 kHz
Power Requirements:	USB powered
Dimensions:	6.7 x 6.5 x 1.5
Weight:	1.13 lbs.

Lexicon engineers are constantly working to improve the quality of our products. Specifications are therefore subject to change without notice.

# Alpha Signal Routing Diagram

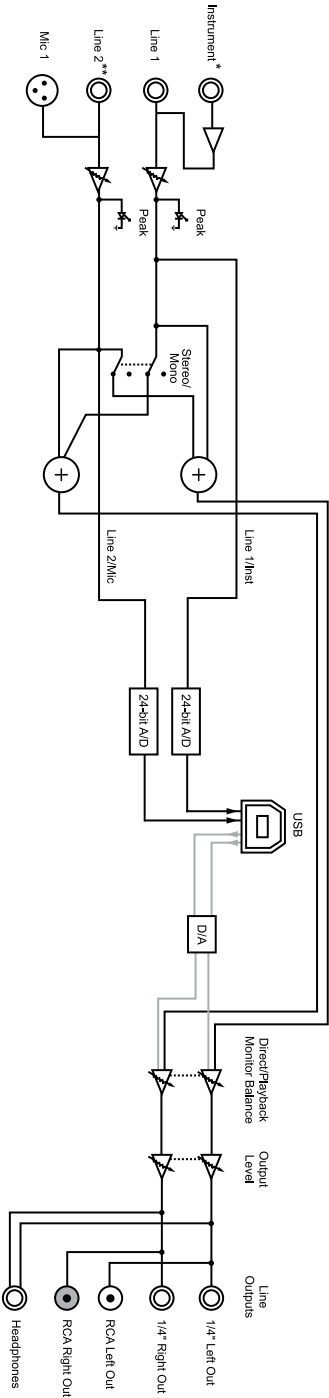

\* Instrument Input  
disables Line 1 input when  
Instrument input has a cable  
inserted into its jack.

\*\* Line 2 Input  
disables Mic input when  
Line 2 input has a cable  
inserted into its jack.



**PHONE:** (801) 566-8800

**WEB:** [lexiconpro.com](http://lexiconpro.com)

**SUPPORT:** [lexiconpro.com/en-US/support](http://lexiconpro.com/en-US/support)

Alpha Owner's Manual

PN: 5058238-A

© 2016 Harman.

All rights reserved.

Lexicon is a registered trademark of Harman.