

electro-harmonix

TRI PARALLEL MIXER

Effects Loop Mixer/Switcher

Congratulations on your purchase of the Electro-Harmonix Tri Parallel Mixer! The Tri Parallel Mixer can be used in multiple configurations for a variety of switching and mixing applications. Use it to switch between or mix up to three separate effects loops. Send a guitar or other instrument out to three separate amplifiers, or input three separate instruments to switch between or mix to a single output. Mix effects in parallel to create sounds and allow for options not possible when using effects in series (one after another). These are a few examples of the multiple ways to incorporate the Tri Parallel Mixer into your setup.

WARNING: Your Tri Parallel Mixer comes equipped with an Electro-Harmonix 9.6DC-200BI power supply (same as used by Boss® & Ibanez®: 9.6 Volts DC 200mA). The Tri Parallel Mixer requires **45mA** at 9VDC with a center negative plug. Use of the wrong adapter or a plug with the wrong polarity may damage your Tri Parallel Mixer and void the warranty.

- USING THE TRI PARALLEL MIXER -

Plug the 9VDC adapter into the jack on the top left of the Tri Parallel Mixer. There are multiple ways to configure your setup, the most typical configuration is shown below: a guitar based setup for mixing and/or switching between three separate effects loops.

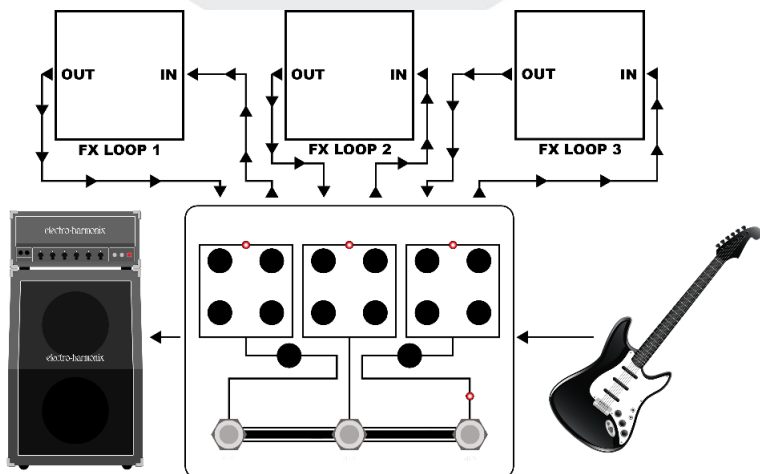

In this configuration, plug your guitar or other instrument/sound source into the INPUT jack on the right of the Tri Parallel Mixer. Connect your amplifier or other sound destination to the OUTPUT jack on the left of the Tri Parallel Mixer. All connections can be made using standard ¼" instrument cables.

Connect the input of the first effect in your first effects loop to the SEND 1 jack. Connect the output of the last effect in your first effects loop to the RTN 1 jack. Repeat this step for your other two effects loops using the SEND 2/3 and RTN 2/3 jacks. Below is the signal path in this configuration:

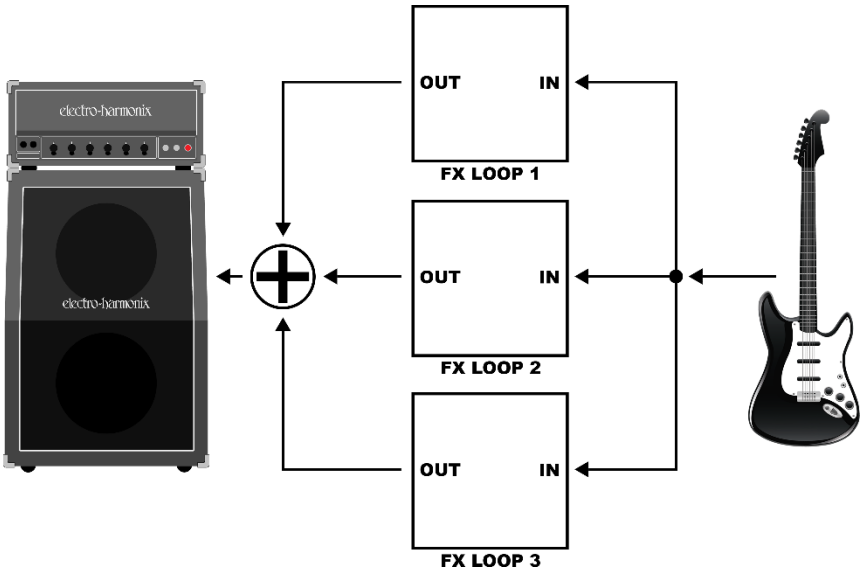

Use the CH 1/2/3 footswitches to activate their respective effects loops. Double tap any of these footswitches to enter master bypass, which connects the INPUT jack directly to the OUTPUT jack. When in bypass, single tap any footswitch to re-enter active mode. There are other switching options and configuration options that will be discussed later in this manual.

-GLOBAL CONTROLS / JACKS-

INPUT – This jack on the right of the unit is the master input for the Tri Parallel Mixer. The signal present here will be outputted to an active channel's SEND jack. In master bypass, the input signal connects directly to the OUTPUT jack.

OUTPUT – This jack on the left of the unit is the master output for the Tri Parallel Mixer.

MASTER VOL – This knob sets the master output level of the mixer.

DRY VOL – This knob sets how much dry signal (the signal present at the INPUT jack) is sent to the output of the Tri Parallel Mixer.

MASTER STATUS – This LED lights when the unit is active and doesn't light when in master bypass. Double tap any of the three footswitches to switch from active to bypass mode. When in bypass, single tap any footswitch to enter active mode. The Tri Parallel Mixer features buffered bypass.

-CHANNEL CONTROLS / JACKS-

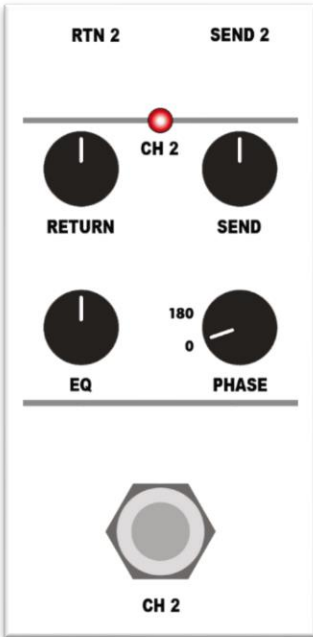

The majority of the controls for the Tri Parallel Mixer are grouped into three identical channel sections, each with a SEND and RTN (Return) jack, a SEND and RETURN level control, an EQ control, a PHASE switch, and a footswitch.

SEND 1/2/3 Jack – This jack outputs the signal inputted to the Tri Parallel Mixer (via the INPUT jack) when its channel is active*. Send output impedance = 220Ω.

SEND Knob – This knob sets the level outputted to the SEND jack.

RTN 1/2/3 Jack – This jack is the input for a given channel. The signal inputted to this jack is sent to the OUTPUT jack (after the EQ control) when its channel is active*. RTN input impedance = 1MΩ.

RETURN Knob – This knob sets the level of the signal received at the RTN jack before it is sent to the output of the Tri Parallel Mixer.

PHASE – This switch, when set to 180, inverts the phase of the signal sent out of the SEND jack. This can be useful when something in your effects loop is causing phase issues when mixed in with either your dry signal or other effects loops.

EQ – This knob affects the tonal characteristic of the signal inputted to the RTN jack. When the knob is at center, there is no effect. Turn the knob up for a brighter signal (more treble) and turn the knob down for a darker signal (more bass).

CH 1/2/3 Footswitch – This switch is used to activate/deactivate a given channel. Double tap any of these switches to enter bypass mode. When in bypass mode, click any of these switches to enter active mode. There are other functions these switches can perform, which will be discussed later.

CH 1/2/3 LED – This LED lights to indicate which channels are active. There are other scenarios where these LEDs may be blinking to indicate different options, which will be discussed later in the manual.

** There are certain scenarios where signal may be active at a given SEND or RTN jack despite that channel being inactive. These scenarios are discussed in the Advanced Switching Options section.*

-ADVANCED SWITCHING OPTIONS-

Before explaining the advanced switching options, it is useful to visualize the signal path of a given channel, which essentially exists in two halves:

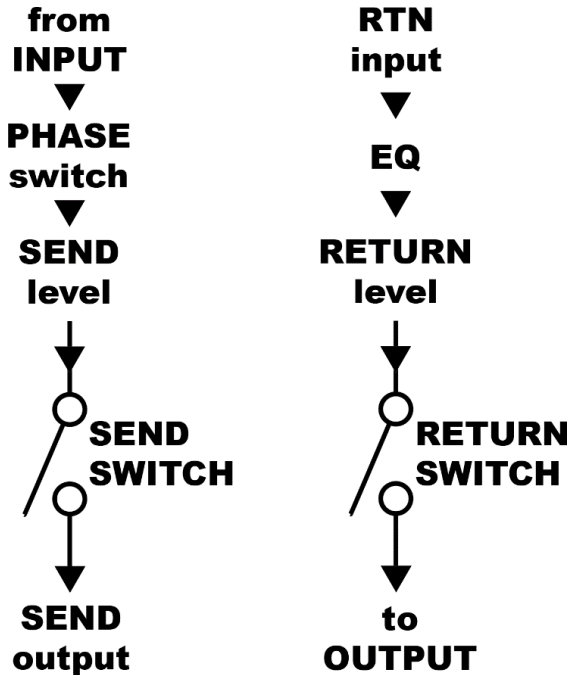

All three channels are setup this way. By default, when a given channel is active both the SEND SWITCH and RETURN SWITCH are closed, allowing signal to flow through them. When a given channel is inactive, both of these switches are open, blocking any signal from flowing. Advance options allow you to change how this works, expanding the Tri Parallel Mixer's possible applications.

BOTH, SEND, & RETURN MUTING MODES

There are three "Muting Modes" that each channel can be independently set to. The default mode, explained above, is BOTH, where when a channel is inactive both the SEND and RETURN sides of the channel are muted. The two other modes are:

SEND MUTING – In this mode, when a channel is inactive only the SEND SWITCH is opened. The RETURN SWITCH is always closed. This is useful if you have an effect such as a delay or reverb in an effects loop channel and you want the tails or decay of that effect to naturally fade out after switching the channel off.

RETURN MUTING – In this mode, when a channel is inactive only the RETURN SWITCH is opened. The SEND SWITCH is always closed and signal will always come out of the SEND 1/2/3 jack even when a channel is inactive.

To switch between these modes:

- 1) Hold any one of the three footswitches down for about a second until all three upper LEDs are blinking.
- 2) Once here, as you press and release a given channel's footswitch, that LED will change blinking speeds.
- 3) There are three blinking speeds, representing the three muting modes. The slowest speed sets that channel to BOTH, the medium speed is SEND MUTING (useful for tails), and the fastest speed is RETURN MUTING.
- 4) Once you've set your channels to the desired modes, hold any one of the three footswitches for about a second until the LEDs stop blinking.

AND / XOR MODES

By default, clicking the footswitch of a given channel turns that channel on or off without affecting any other channels. This is called AND Mode. You can also set the Tri Parallel Mixer to XOR (exclusive or) Mode. In this mode, only one of the three channels can be active at a time.

Switching on one channel automatically switches off the other two. This is useful to use the Tri Parallel Mixer as more of a switcher and less of a mixer.

To switch between these modes:

- 1) Hold the CH 1 and CH 2, or the CH 2 and CH 3 footswitch together, for about a second, until the three upper LEDs are blinking.
- 2) The LEDs will either be blinking in unison, indicating AND Mode, or blinking one after another, indicating XOR Mode.
- 3) To change the setting, simply press and release any of the three footswitches.
- 4) Once you have set it to your desired setting, hold down any one of the three footswitches for about a second, until the LEDs stop blinking.

FACTORY RESET

Upon powering up, the Tri Parallel Mixer will remember your last settings, as far as which channels were active and the current Muting Mode and AND/XOR Mode. To easily reset everything to the default settings, perform a factory reset by following these steps:

- 1) Unplug the 9V power from the Tri Parallel Mixer
- 2) Hold down the CH 1 and CH 3 footswitches
- 3) While still holding them down, plug in the 9V power
- 4) All four LEDs will light for about a half second, then the top three LEDs will go off. The Factory Reset is complete.

-PARALLEL EFFECT MIXING-

In a traditional setup with multiple effects pedals, effects are run in series, with the output of one connected to the input of the next. In this configuration the sound created by an effect earlier in the chain will greatly affect any effects used later in the chain. The Tri Parallel Mixer allows you to use effects in parallel, where each effect acts on your input signal independently, and is then combined. This allows for tonal options not possible when running effects in series. A couple of examples are shown and explained below:

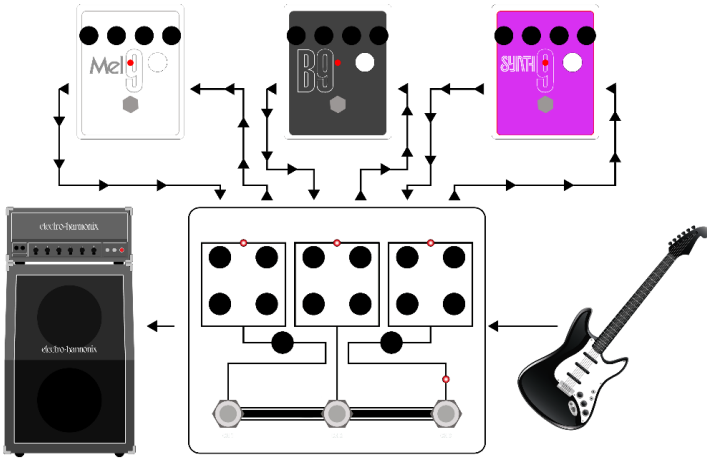

In the example above, you can use three separate effects from the EHX 9 Series, in this case a Mel9 Tape Replay Machine, B9 Organ Machine, and Synth9 Synthesizer Machine, and combine them in parallel to create a mix of mellotron, organ, synthesizer, and guitar tone.

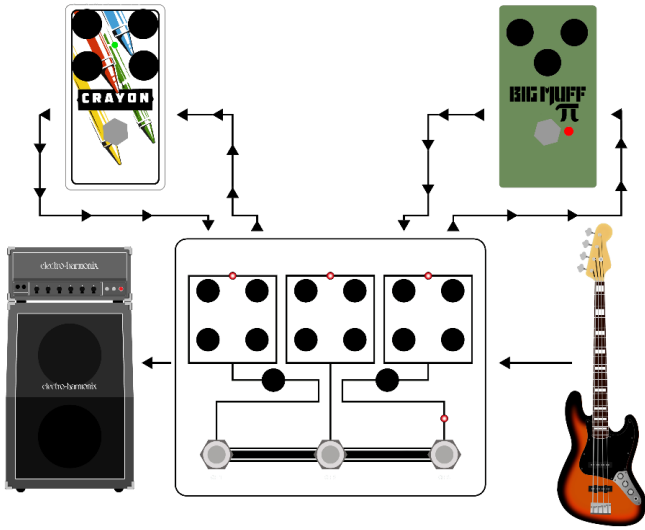

In the example above, mixing two very different overdrives on bass, in parallel, can result in a very full and unique distorted bass tone. You can also use the built in DRY blend on the Tri Parallel Mixer to retain some of the bass guitar's natural low end.

-OTHER CONFIGURATIONS-

Over the next couple of pages, some other possible configurations and applications of the Tri Parallel Mixer will be shown to help illustrate multiple ways you can use the unit.

Figure 1

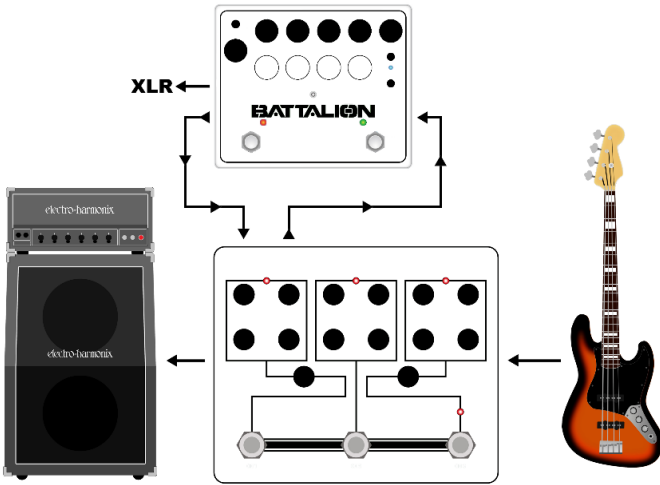

Figure 2



Figure 3

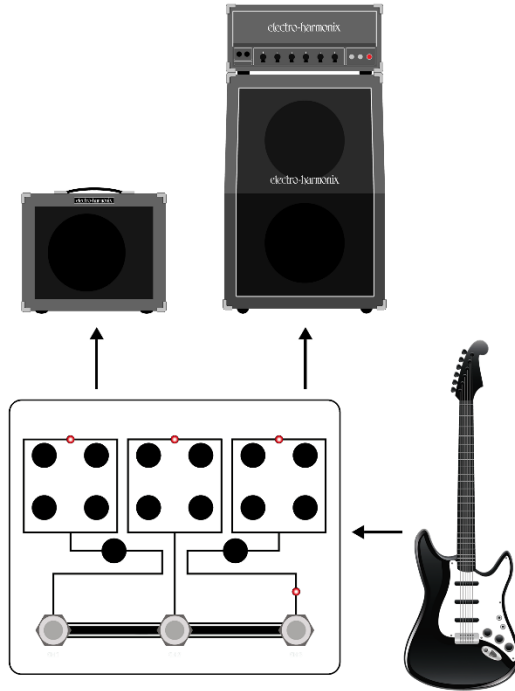

Figure 1: An example where you may make use of RETURN MUTING mode. Even when channel one is inactive, bass guitar signal will still flow out of the SEND 1 jack and into the EHX Battalion Bass Preamp/DI. This allows the signal to always come out of the Battalion's XLR out, but only when the channel is active would it be routed to the amp.

Figure 2: An example of using the Tri Parallel Mixer as an instrument switcher. Plug each instrument into a channel's RTN jack, then set the Tri Parallel Mixer to XOR switching mode and click a channel to select that instrument. Use the RETURN knob for a given channel to adjust the level of just that instrument.

Figure 3: An example using the Tri Parallel Mixer to send a guitar to two separate amplifiers. You could either instantaneously switch between the two amplifiers or simultaneously send your guitar signal to both. Use the SEND knob for a given channel to set the level of the signal sent into the amplifier.

- WARRANTY INFORMATION -

Please register online at <http://www.ehx.com/product-registration> or complete and return the enclosed warranty card within 10 days of purchase. Electro-Harmonix will repair or replace, at its discretion, a product that fails to operate due to defects in materials or workmanship for a period of one year from date of purchase. This applies only to original purchasers who have bought their product from an authorized Electro-Harmonix retailer. Repaired or replaced units will then be warranted for the unexpired portion of the original warranty term.

If you should need to return your unit for service within the warranty period, please contact the appropriate office listed below. Customers outside the regions listed below, please contact EHX Customer Service for information on warranty repairs at info@ehx.com or +1-718-937-8300. USA and Canadian customers: please obtain a **Return Authorization Number (RA#)** from EHX Customer Service before returning your product. Include—with your returned unit—a written description of the problem as well as your name, address, telephone number, e-mail address, RA# and a copy of your receipt clearly showing the purchase date.

United States & Canada

EHX CUSTOMER SERVICE
ELECTRO-HARMONIX
c/o NEW SENSOR CORP.
55-01 2ND STREET
LONG ISLAND CITY, NY 11101

Tel: 718-937-8300
Email: info@ehx.com

Europe

JOHN WILLIAMS
ELECTRO-HARMONIX UK
13 CWMDONKIN TERRACE
SWANSEA SA2 0RQ
UNITED KINGDOM

Tel: +44 179 247 3258
Email: electroharmonixuk@virginmedia.com

To hear demos of all EHX pedals visit us on the web at www.ehx.com

Email us at info@ehx.com

- FCC COMPLIANCE -

This device complies with part 15 of the FCC Rules. Operation is subject to the following two conditions: (1) This device may not cause harmful interference, and (2) this device must accept any interference received, including interference that may cause undesired operation. If the device is not installed and used in accordance with the instructions, it may cause harmful interference to radio communications and void the user's authority to guarantee the equipment.

Note: This equipment has been tested and found to comply with the limits for a Class B digital device, pursuant to part 15 of the FCC Rules. These limits are designed to provide reasonable protection against harmful interference in a residential installation. This equipment generates, uses and can radiate radio frequency energy and, if not installed and used in accordance with the instructions, may cause harmful interference to radio communications. However, there is no guarantee that interference will not occur in a particular installation. If this equipment does cause harmful interference to radio or television reception, which can be determined by turning the equipment off and on, the user is encouraged to try to correct the interference by one or more of the following measures:

- *Reorient or relocate the receiving antenna.*
- *Increase the separation between the equipment and receiver.*
- *Connect the equipment into an outlet on a circuit different from that to which the receiver is connected.*
- *Consult the dealer or an experienced radio/TV technician for help.*

Modifications not expressly approved by the manufacturer could void the user's authority to operate the equipment under FCC rules.



The CE logo indicates that this product has been tested and shown to conform with all applicable European Conformity directives.

