

# FX1 MIDI Footcontroller

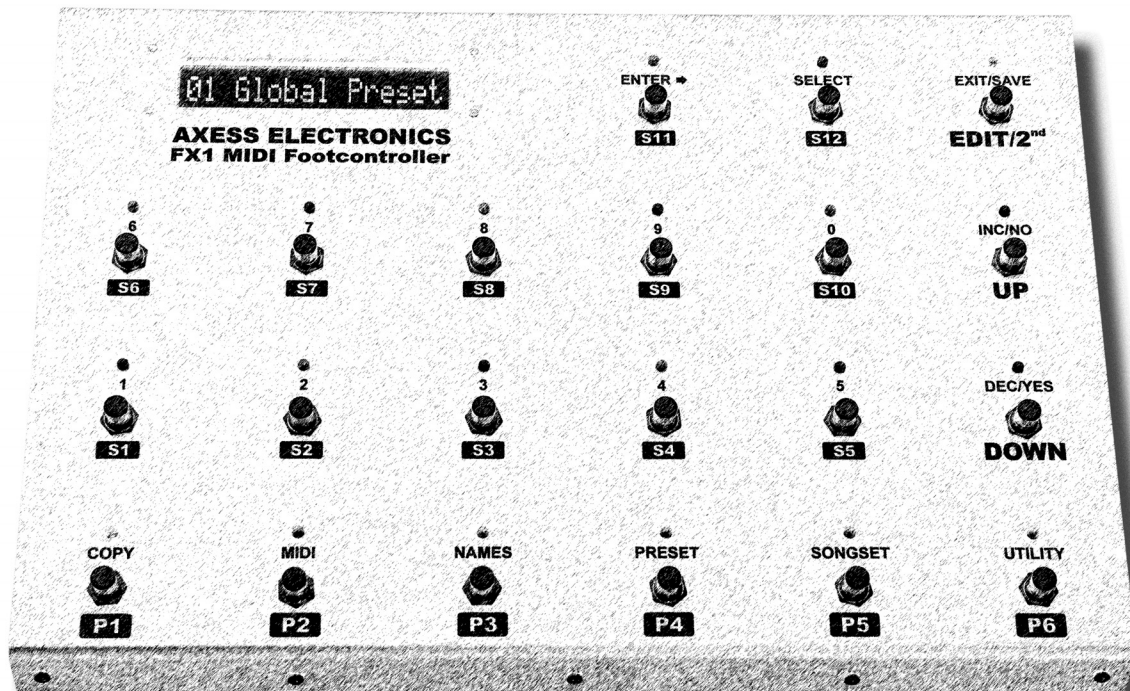

# Axess Electronics

*User Manual Revision 4*



# Table of Contents

|  |           |
|--|-----------|
| <b>1. Warranty.....</b>                          | <b>5</b>  |
| <b>2. Precautions.....</b>                       | <b>5</b>  |
| <b>3. Introduction .....</b>                     | <b>6</b>  |
| 3.1 Features List .....                          | 6         |
| <b>4. Fundamentals .....</b>                     | <b>7</b>  |
| <b>5. Quick Start.....</b>                       | <b>8</b>  |
| <b>6. Display.....</b>                           | <b>9</b>  |
| <b>7. Switches &amp; LED's.....</b>              | <b>10</b> |
| 7.1 Primary Switch Functions.....                | 10        |
| 7.1.1 EDIT/2 <sup>nd</sup> .....                 | 10        |
| 7.1.2 UP & DOWN .....                            | 10        |
| 7.1.3 P1 – P6 .....                              | 11        |
| 7.1.4 S1 – S12 .....                             | 11        |
| 7.1.5 S13 – S24 .....                            | 11        |
| 7.2 Secondary Switch Functions.....              | 12        |
| 7.2.1 COPY.....                                  | 12        |
| 7.2.2 MIDI .....                                 | 12        |
| 7.2.3 NAMES .....                                | 12        |
| 7.2.4 PRESET.....                                | 12        |
| 7.2.5 SONGSET .....                              | 12        |
| 7.2.6 UTILITY.....                               | 12        |
| 7.2.7 0 – 9 .....                                | 12        |
| 7.2.8 SELECT.....                                | 12        |
| 7.2.9 ENTER ➔ .....                              | 12        |
| 7.2.10 INC/NO & DEC/YES .....                    | 12        |
| 7.2.11 EXIT/SAVE .....                           | 13        |
| <b>8. Rear Panel.....</b>                        | <b>14</b> |
| 8.1.1 XPDL:1.....                                | 14        |
| 8.1.2 XPDL:2.....                                | 14        |
| 8.1.3 XPDL:3.....                                | 14        |
| 8.1.4 XPDL:4.....                                | 14        |
| 8.1.5 S11:S12.....                               | 14        |
| 8.1.6 9VAC:0.4A .....                            | 15        |
| 8.1.7 MIDI IN.....                               | 15        |
| 8.1.8 MIDI OUT.....                              | 15        |
| 8.1.9 TO RACK.....                               | 15        |
| 8.1.10 EXPANDER.....                             | 15        |
| <b>9. Power On.....</b>                          | <b>16</b> |
| <b>10. Edit Mode .....</b>                       | <b>17</b> |
| <b>11. Copy Menu.....</b>                        | <b>18</b> |
| 11.1 Preset Copy .....                           | 18        |
| 11.2 Bank Copy .....                             | 19        |
| 11.3 Song Copy .....                             | 20        |
| 11.4 Setlist Copy.....                           | 21        |
| 11.5 Instant Access Switch Copy.....             | 22        |
| <b>12. MIDI Menu .....</b>                       | <b>23</b> |
| 12.1 Receive MIDI Channel.....                   | 23        |
| 12.2 Program Change Starting Number.....         | 24        |
| 12.3 S1 – S24 Control & Program Changes .....    | 25        |
| 12.4 Internal Control Changes .....              | 27        |
| 12.5 XP1 – XP4 Global Settings .....             | 28        |
| 12.6 S1 – S12 Custom Hex/MIDI Message .....      | 30        |
| 12.6.1 MIDI Messages For Guitar Players 101..... | 32        |

# Table of Contents

|  |           |
|--|-----------|
| <b>13. Names Menu .....</b>                            | <b>35</b> |
| 13.1 Song Names .....                                  | 35        |
| 13.2 Setlist Names.....                                | 36        |
| 13.3 MIDI Channel Names.....                           | 37        |
| 13.4 Instant Access Switch Names.....                  | 38        |
| 13.5 Internal Control Change Names.....                | 39        |
| <b>14. Preset Menu .....</b>                           | <b>40</b> |
| 14.1 Preset Select.....                                | 40        |
| 14.2 Preset Name .....                                 | 41        |
| 14.3 Program Change Messages .....                     | 42        |
| 14.4 Instant Access Switch On/Off Status .....         | 43        |
| 14.5 Internal Control Change On/Off Status .....       | 44        |
| 14.6 XP1 – XP4 Preset Settings .....                   | 45        |
| 14.7 Preset Custom Hex/MIDI Message.....               | 47        |
| 14.7.1 MIDI Messages For Guitar Players 101.....       | 48        |
| <b>15. SongSet Menu .....</b>                          | <b>51</b> |
| 15.1 Song Create/Edit.....                             | 51        |
| 15.2 Setlist Create/Edit .....                         | 52        |
| <b>16. Utility Menu.....</b>                           | <b>53</b> |
| 16.1 Operating Mode .....                              | 53        |
| 16.2 S1 – S12 Switch Link .....                        | 54        |
| 16.3 Instant Access Switch Type .....                  | 56        |
| 16.4 XP1 – XP4 Port Type.....                          | 57        |
| 16.5 XP1 – XP4 Port Calibration.....                   | 58        |
| 16.5.1 Calibrating An Expression Pedal Port.....       | 58        |
| 16.6 Global Preset Availability .....                  | 60        |
| 16.7 Data Dump/Load.....                               | 61        |
| 16.7.1 Remote Data Dump/Load .....                     | 61        |
| 16.8 Delete/Restore .....                              | 62        |
| 16.9 Firmware Version & Update.....                    | 64        |
| 16.9.1 Updating The FX1 Firmware.....                  | 64        |
| <b>17. Cables .....</b>                                | <b>66</b> |
| 17.1.1 XPDL & External Switch .....                    | 66        |
| 17.1.2 XPDL & External Volume Pedal.....               | 66        |
| 17.1.3 XPDL & External Expression Pedal.....           | 66        |
| 17.1.4 S11:S12 & External Dual Footswitch.....         | 67        |
| 17.1.5 S11:S12 & Two External Footswitches.....        | 67        |
| 17.1.6 S11:S12 & Single External Footswitch (S11)..... | 68        |
| 17.1.7 S11:S12 & Single External Footswitch (S12)..... | 68        |
| <b>18. Remote Control.....</b>                         | <b>69</b> |
| 18.1.1 PRST Operating Mode.....                        | 69        |
| 18.1.2 SETn Operating Mode .....                       | 69        |
| 18.1.3 SONG Operating Mode.....                        | 69        |
| <b>19. Master/Slave Loop .....</b>                     | <b>70</b> |
| 19.1.1 Master/Slave Connections.....                   | 70        |
| 19.1.2 Master/Slave Cable Details.....                 | 71        |
| 19.1.3 Power Supply/Adapter Details.....               | 71        |
| 19.1.4 A Few Things To Remember.....                   | 71        |
| <b>20. Factory Default Settings.....</b>               | <b>72</b> |
| <b>21. MIDI Implementation Chart .....</b>             | <b>73</b> |
| <b>22. Controlling Multiple GCX's.....</b>             | <b>74</b> |
| <b>23. User Manual Revision History .....</b>          | <b>75</b> |

# 1. Warranty

This product is warranted against failures due to defective parts or faulty workmanship for a period of one year after delivery to the original owner. During this one year period, Axess Electronics will make any necessary repairs without charge for parts and labor. However, shipping charges to and from the repair location must be paid by the owner.

This warranty applies only to the original owner and is not transferable.

This warranty does not cover damage to the product as a result from accident or misuse.

This warranty will be canceled at the sole discretion of Axess Electronics if the product has:

- Any signs of tampering, unauthorized service, or modifications.
- Any damage resulting from physical abuse or failure to follow the operating instructions.

Axess Electronics reserves the right to make any changes and/or improvements to the design of this product without any obligation to include those changes in any previously manufactured units.

Axess Electronics' liability to the owner and under this warranty is limited only to the repair or replacement of the defective product. Call or write to Axess Electronics prior to shipping the product for repair.

## How To Reach Us

Mail: Axess Electronics  
251 Queen Street South #278  
Mississauga, Ontario L5M1L7  
Canada

Tel. No.: 416-410-9688

Website: <http://www.axess-electronics.com>

# 2. Precautions

It is VERY important to read this section carefully to ensure years of reliable operation from this device. Failure to follow these precautions WILL void the warranty and may result in Axess Electronics' refusal to service/support the device in the future.

Do NOT remove the cover from this device at any time.

Do NOT tamper with, make any internal adjustments or additions to this device at any time.

Do NOT use this device near water and/or allow any liquid to spill into it through any of its openings.

Do NOT drill any part of the chassis to secure this device to a pedalboard, use 3M Dual-Lock instead.

Do NOT drill the bottom of the chassis to attach rubber-feet, use the supplied self-adhesive 3M rubber-feet instead.

Do NOT use any solvents (such as Benzene etc.) to clean the exterior. ONLY use a dry soft cloth to remove dust/dirt.

Do NOT attempt to service this device and/or have anyone else attempt to service this device other than Axess Electronics.

Do NOT expose this device to excessive heat. It has been designed and tested to operate between 0 °C and 45 °C (32 °F and 113 °F). This device may shut down under extreme temperature conditions.

# 3. Introduction

Thank you for purchasing the Axess Electronics FX1 MIDI Footcontroller.

After reviewing the introduction section of some other user manuals for inspiration, I noticed they usually start with the word “congratulations” and include words such as “finest”, “most powerful” and “ultimate” when describing the product. I was going to use similar words, as I probably have in other user manuals, but instead I decided not to and will leave that up to you and others.

I designed the FX1 to be rugged, reliable, full featured, yet simple to program and operate, whether on stage in front of tens of thousands or just tens of tens etc. Hopefully I have succeeded and you think it’s worthy of being described as one of the “finest”, “most powerful” and “ultimate” MIDI footcontrollers around.

I would also like to thank the following people without whom the FX1 would not have been possible for one reason or another. My wife, daughter and dog – for hesitantly allowing me to work crazy hours and sacrificing a whole lot of quality family time, Daryl Speers – the unbelievably talented software engineer who made my FX1 dream/design a reality, Mike Marino – thanks for you know what bro, Gil Elgez, Kevin Young, Lonnie Totman, Dave Friedman, the loyal Axess followers who placed advance orders, sight unseen, and the handful of other’s who gave me ideas.

Mario Marino, President  
AXESS ELECTRONICS

## 3.1 Features List

- 6 preset switches (blue LED's).
- 12 instant access switches (green LED's).
- Edit/2nd (red LED), Bank Up & Down switches with yellow LED's.
- 127 preset memory locations.
- 21 banks of 6 presets, plus a Global Preset.
- Four (global and per preset) expression pedal ports.
- Large 1-line x 16-character LCD display w/backlight.
- Song & setlist modes.
- Create up to 99 songs.
- Organize the 99 songs into 10 setlists of 50 songs.
- Heavy-duty *Carling* stomp switches (the real ones).
- Switches are spaced 3.00" apart in every direction.
- Master/Slave functionality for multiple footcontroller rigs.
- Expression pedal port calibration.
- Bulk data dump and load capabilities.
- Software upgrades via its MIDI IN jack.
- Scroll through banks/songs without activating a preset.
- Easily copy presets, banks, songs, setlists and instant access switches.
- Easily name presets, songs, setlists, MIDI channels, instant access switches and more.
- Individually configure instant access switches to operate as latching type or hold type switches.
- Each instant access switch can transmit two control change messages and two program change messages (one when the switch is on and the other when it's off).
- Multiple instant access switches can be linked together to allow for quick/easy selection and indication of which channel is on, on multi-channel guitar amps, all with the press of one switch.
- Instant access switches and presets are capable of sending custom 16 byte hex/MIDI messages.
- Presets can simultaneously transmit program change messages (starting at 000 or 001 - user selectable for each MIDI channel) on all 16 MIDI channels.
- Standard (5-pin) MIDI IN and MIDI OUT jacks.
- Heavy-duty TO RACK (5-pin) XLR MIDI OUT jack.
- Powered by a 9VAC adapter (which is included) with a 5.5mm/2.1mm barrel connector or phantom powered via the TO RACK or MIDI OUT jacks.
- Rugged 0.118" (3mm) thick aluminum enclosure.
- Dimensions - 18.00"W x 12.00"D x 1.25"FH x 3.50"RH
- Brush finish with black anodize coating & laser-engraved printing.
- Optional 12 instant access switch expander.
- The FX1 will automatically sense the expander is connected, no software upgrade is necessary.
- Powered by the FX1 via the included XLR cable.
- Same physical / mechanical attributes of the FX1.
- Dimensions - 9.00"W x 12.00"D x 1.25"FH x 3.50"RH

# 4. Fundamentals

The FX1 MIDI Footcontroller has four different operating modes, plus the Edit Mode (see Section 10). The operating modes are;

Slave (SLAV)  
Preset (PRST)  
Songs (SONG)  
Setlist (SET0 – SET9)

The PRST Operating Mode (factory default) allows the FX1 to behave like a standard footcontroller with banks (21) of presets (6) plus a Global Preset.

The SONG Operating Mode allows access to the FX1's 99 songs. Songs are basically a custom bank of the FX1's regular (banked) presets, arranged so that all the presets necessary during the performance of a song are available in one bank (conveniently called a song).

The SET0 – SET9 Operating Mode(s) allow up to 50 of the FX1's 99 songs to be arranged in any order to create a setlist. The FX1 can support 10 different setlists.

The SLAV Operating Mode allows multiple FX1's (setup in a Master/Slave Loop) to control the same guitar rig from remote onstage and offstage locations. When connecting multiple FX1's in a Master/Slave Loop, one FX1 must be set to a master operating mode (PRST, SONG or SET0 – SET9) and all the other FX1's must be set to the SLAV Operating Mode. When in this operating mode, the FX1 will mimic the master FX1's operating mode.

While in one of the above operating modes, the display is used to provide three different pieces of information.

The first two characters on the left-hand side of the display indicate the bank or song number, depending on the operating mode selected.

The third character (from the left) will always be blank except when it periodically flashes a small character to indicate the current operating mode.

The final 13 characters on the display are used to show the user assigned name for the preset or song, depending on the operating mode selected.

Preset switches **P1** to **P6** are used to select a preset, instant access switches **S1** to **S12** (to **S24** if the expander is connected) are used to turn a specific loop or function in the guitar rig ON or OFF, and the **UP** and **DOWN** switches are used to select a bank or song, depending on the operating mode selected.

When a preset is selected, the MIDI data programmed for the preset, as well as the ON or OFF state MIDI messages of all the instant access switches, will be transmitted via the MIDI OUT and TO RACK jacks. Preset switches allow every piece of gear in a guitar rig to be switched at the same time with the press of one switch.

Instant access switches can be pressed at any time to turn a turn the specific loop or function in a guitar rig ON and OFF in real-time, without affecting anything else in the rig. When an instant access switch is pressed, its ON or OFF state (indicated by its LED) MIDI messages will be transmitted via the MIDI OUT and TO RACK jacks. The LED above the **EDIT/2nd** switch will begin to flash after an instant access switch has been pressed indicating that the preset has been changed. Pressing the **EDIT/2nd** switch when its LED is flashing will update/save the preset with the new ON/OFF settings of the instant access switches. Alternatively, pressing the active preset switch or selecting another preset will recall and transmit its stored MIDI data/settings or the instant access switch(es) can be pressed to return the preset to its stored state, both of which cause the **EDIT/2nd** switch LED to stop flashing.

Pressing the **UP** and **DOWN** switches will select a new bank or song number depending on the operating mode selected. After pressing either of these switches, the bank or song number will begin to flash, indicating the number shown is not current. Pressing a preset switch will select the appropriate preset in the new bank or song, otherwise pressing the **UP** or **DOWN** switch to return back to the current bank or song will cause the number to stop flashing.

# 5. Quick Start

1. If using the optional expander, be sure to connect it to the FX1 using ONLY the supplied cable and ONLY when the power is off (see Section 8.1.10 for details).
2. See Section 4 : Fundamentals to get a basic understanding of the FX1 user interface, and for avid readers see Section 6 to Section 9 for a detailed description of the user interface.
3. Connect a MIDI cable from either the TO RACK jack or the MIDI OUT jack on the FX1 to the main MIDI input point/jack of the guitar rig/switcher being controlled by the FX1 (see Sections 8.1.8 and 8.1.9).
4. If the FX1 is not receiving 9Vac phantom power from the guitar rig/switcher it's controlling, connect the supplied adapter to the FX1 power jack (see Section 8.1.6).
5. Enter the Edit Mode (see Section 10).
6. Verify that the (factory default) PRST Operating Mode is selected (see Section 16.1).
7. Decide what will be connected to each expression pedal port (see Sections 16.4 and 17.1.1 to 17.1.3) and then calibrate each pedal/switch (see Section 16.5).
8. Setup the global MIDI control change message that each expression pedal port will transmit (see Section 12.5).
9. Decide what loops and switching functions in the guitar rig the instant access switches will control and setup the MIDI control change and/or program change messages that each instant access switch will transmit when pressed and as part of a preset (see Section 12.3).
10. Assign a name for each instant access switch being used (see Section 13.4).

*FYI - When labeling the instant access switches with self-adhesive labels, align the top edge of the label with the bottom edge of the "boxed" instant access switch number (S1 – S12 or S24 with the expander) so that all the labels are aligned perfectly... There is enough room under each instant access switch (except S13 – S15 on the expander) to accommodate two 1/2" labels or three 3/8" labels.*

11. Assign the name of each MIDI device in the guitar rig to its corresponding MIDI channel (see Section 13.3).
12. Select a preset to be programmed (see Section 14.1) and name it (see Section 14.2).
13. Setup any MIDI program change messages that the preset should transmit when selected (see Section 14.3).
14. Turn the loops and/or switching functions controlled by the instant access switches ON or OFF for the preset being programmed (see Section 14.4). This step can also be performed while in the PRST Operating Mode as outlined in Section 4 and detailed in Section 7.2.11).
15. If it's necessary to have the expression pedal ports control something different/specific for the preset being programmed than what was entered in Step #8, see Section 14.6.

The FX1 is ready to go !!! Repeat Step #12 to Step #15 for other presets.

*Please note that the FX1 can transmit a LOT of MIDI data when a preset switch is selected. In fact, if every possible MIDI message that the FX1 is capable of transmitting per preset is enabled and used, the total number of bytes transmitted would be 516. The MIDI specification stipulates that a single MIDI event (such as when a preset switch is pressed) should be kept to 255 bytes or less. The FX1 will not place a restriction on how many or which of its MIDI messages can be enabled and used, so this is one of the reasons that the FX1 is shipped with all its MIDI messages and features turned off. Therefore the only MIDI messages transmitted by the FX1 will be what have been turned on and/or programmed into it. It's very unlikely that anyone will ever need to use all of the features that have been put into the FX1, but they are there to provide options, so just use some restraint...*



# 6. Display

The display is a 1-line by 16-character dot-matrix LCD with a backlight.

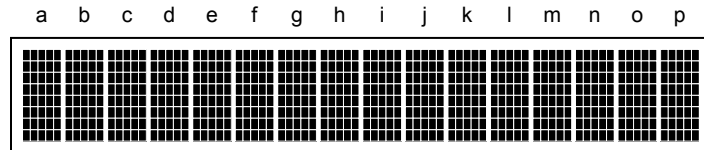

When in the Edit Mode, the display will show the parameter(s) being edited.

When in the Slave (SLAV) Operating Mode the display will show the exact same information as the display on the master FX1 (see Section 19 : Master/Slave Loop for more information).

In the Preset (PRST) Operating Mode the display will show the bank number (01 to 21) at display locations a and b, and at display locations d to p the 13-character user defined preset name.

In the Songs (SONG) Operating Mode the display will show song number 01 to 99 at display locations a and b, and when in one of the ten Setlist (SET0 – SET9) Operating Modes the display will show song number 01 to 50.

For the SONG and SET0 – SET9 Operating Modes, display locations d to p will show either the 13-character user defined song name (when the **UP / DOWN** switches are pressed to select a new song) or the 13-character user defined preset name (when a preset is selected via preset switches **P1 - P6**). To have the display always show the song name, apply power to the FX1 while pressing the **P3** switch. To revert back to displaying the song and preset names as described above, apply power to the FX1 while pressing the **P4** switch. This “display setting” is stored in the FX1’s memory, so applying power with one of these switches pressed only needs to be done once to select it.

When in one of the above “Operating Modes”, the 3<sup>rd</sup> display character (location c – a blank character between the bank/song number and the preset/song name) will be used to indicate the operating mode by periodically flashing a small operating mode indicator/character. The letter “**P**” will flash to indicate the Preset (PRST) Operating Mode, the letter “**G**” will flash to indicate the Songs (SONG) Operating Mode, a number between “**0**” and “**9**” will flash to indicate the Setlist (SET0 – SET9) Operating Mode and the letter “**V**” will flash to indicate the Slave (SLAV) Operating Mode.

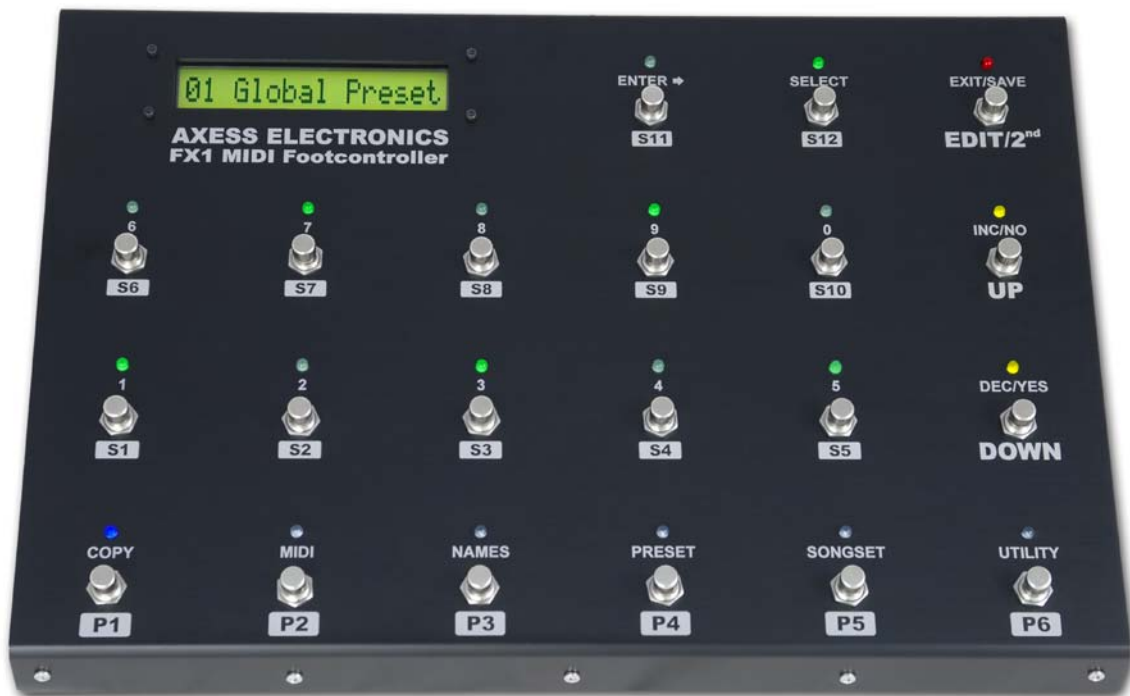

# 7. Switches & LED's

The FX1 top panel is fitted with 21 heavy-duty Carling stomp switches. Each switch has dual functions, the primary function is listed underneath the switch and the secondary function is listed between the switch and its LED. The primary function is used when the FX1 is in one of the above mentioned "Operating Modes" and the secondary function is used when the FX1 is in the Edit Mode.

When not in the Edit Mode (i.e. one of the above "Operating Modes"), the LED above the **EDIT/2nd** switch will be OFF, indicating that the primary switch functions are available.

When in the Edit Mode, the LED above the **EDIT/2nd** switch will always be ON and one or all of the **P1** to **P6** switch LED's will flash, indicating that the Edit Mode or one of its sub-menu's has been selected. Only the LED for switches that have a purpose or function when in the Edit Mode or one of its sub-menu's will be ON, all others will be OFF.

## 7.1 Primary Switch Functions

### 7.1.1 *EDIT/2<sup>nd</sup>*

This switch allows entry to the Edit Mode. To avoid entering the Edit Mode when accidentally pressing this switch, it is equipped with a delay. So to enter the Edit Mode, press and hold this switch down for 1 second, all the LED's will turn OFF except the LED above this switch which will turn ON, and the **P1** to **P6** switch LED's which will start flashing.

### 7.1.2 *UP & DOWN*

When in one of the "Operating Modes", the LED above these switches will always be ON making it a little easier to see where the switches are on a darkened stage.

When in the PRST Operating Mode, pressing and releasing these switches will move up and down through a bank of presets, one bank at a time. Holding down these switches will scroll up and down through banks of presets, they are repetitive accelerating and the bank number will rollover (upwards) from 21 to 01 and (downwards) from 01 to 21.

As soon as one of these switches has been pressed, the bank number will start to flash indicating the bank has been changed. No preset will be selected in the new bank until a preset switch has physically been pressed. While the bank number is flashing, the operating mode indicator will remain off and the preset name and ON/OFF status of the instant access switch LED's will remain unchanged.

Pressing either of these switches to return to the original bank will cause the bank number to stop flashing. Selecting a preset in the new bank will also cause the bank number to stop flashing and it will update the display with the new preset name and the ON/OFF status of the instant access switch LED's will also be updated as per the new preset.

When in the SONG or one of the SET0 – SET9 Operating Modes, pressing and releasing these switches will move up and down through a song, one song at a time. Holding down these switches will scroll up and down through songs, they are repetitive accelerating and the song number will rollover (upwards) from 99 to 01 and (downwards) from 01 to 99 when in the SONG Operating Mode and (upwards) from 50 to 01 and (downwards) from 01 to 50 when in one of the SET0 – SET9 Operating Modes.

As soon as one of these switches has been pressed, the song number will start to flash indicating the song has been changed. No preset will be selected in the new song until a preset switch has physically been pressed. While the song number is flashing, the operating mode indicator will remain off and ON/OFF status of the instant access switch LED's will remain unchanged, but the song name will change to reflect the new (flashing) song number, allowing for verification of the next/queued song.

Pressing either of these switches to return to the original song will cause the song number to stop flashing. Selecting a preset in the new song will also cause the song number to stop flashing and the ON/OFF status of the instant access switch LED's will be updated as per the new preset.

## 7.1 Primary Switch Functions (Cont'd)

### 7.1.3 P1 – P6

These are (six) preset switches and they recall presets 1 to 6 or the Global Preset. Presets allow all the devices in a guitar rig to be controlled with the press of one switch, a preset switch. Only one preset can be active at a time and the LED's above the preset switches are used to indicate which it is. Though the FX1 has six preset switches, it is actually capable of recalling seven presets. The seventh preset is called the Global Preset and it is selected by pressing the preset switch that is active (the LED above the preset switch will be ON). When all the preset switch LED's are OFF, it indicates that the Global Preset is active.

Realizing that some guitarists might not like the possibility of pressing a preset switch by accident and selecting the Global Preset, the FX1 allows for the Global Preset to be disabled (see Section 16.6 : Global Preset Availability for more information). When the Global Preset is disabled, pressing the active preset switch will cause the FX1 to do, and transmit, absolutely nothing.

When in the PRST Operating Mode, the Global Preset is the same in every bank and when in the SET0 – SET9 or SONG Operating Modes, the Global Preset is unique to the selected song.

Presets transmit MIDI messages specific to the selected preset (such as MIDI program change messages and a custom 16 byte hex/MIDI message) as well as the ON or OFF state MIDI messages of all the instant access switches and internal control changes, depending on whether they are supposed to be ON or OFF for the selected preset.

### 7.1.4 S1 – S12

These are (twelve) instant access switches and they are used to turn a specific function (such as an audio loop or a switching function on a guitar router/switcher) ON or OFF without affecting any other audio loops, switching functions or devices within a guitar rig.

The LED above each instant access switch will indicate whether the function controlled by the switch is ON or OFF.

Typically (on other footcontrollers) instant access switches only transmit a single MIDI control change message. This has proven to be very limiting for a lot of guitarists, so the FX1's instant access switches have been designed with the ability to transmit two MIDI control change messages, two MIDI program change messages (one when the switch is ON and the other when it is OFF) and two custom 16 byte hex / MIDI messages (one when ON and one when OFF).

Another feature designed into the FX1 is the ability to select how each instant access switch will operate when pressed and released, each can be configured to operate as a latching switch or as a hold type switch. Pressing and releasing a latching switch once will turn it ON and transmit its ON state MIDI messages, pressing and releasing the switch again will turn it OFF and transmit its OFF state MIDI messages. Pressing a hold type switch will turn it ON and transmit its ON state MIDI messages and releasing the switch will turn it OFF and transmit its OFF state MIDI messages. When selecting a preset on the FX1, the ON/OFF state MIDI messages for hold type instant access switches are NOT transmitted as part of the preset. The default switch type for all instant access switches is latching.

The final feature (which Axess is the 1<sup>st</sup> to offer) designed into the FX1's instant access switches is the ability to link up to two sets of instant access switches. Each linked set may contain up to four instant access switches. When instant access switches are linked together in a set, only one of the instant access switches can be ON at any time, in each set. So pressing an instant access switch that is OFF will turn it ON and the instant access switch that was ON before will turn OFF automatically. See Section 16.2 : S1 – S12 Switch Link for more information.

### 7.1.5 S13 – S24

These are (twelve) more instant access switches located on the optional expander. They offer similar features and functionality as **S1 – S12** on the FX1, but they cannot be linked and they don't support custom hex/MIDI messages.

*Please note that unlike the footcontrollers and expanders offered by other companies, the FX1 does not require an expander to be connected in order for the FX1 to transmit the MIDI messages associated with the expander's instant access switches when a preset is selected. So to recap, if the expander is disconnected or one is never connected at all, the FX1 will continue to transmit the MIDI messages associated with the expander whenever a preset is selected.*

## **7.2 Secondary Switch Functions**

### **7.2.1 COPY**

When at the main Edit Menu, pressing this switch will select and move through the Copy Menu.

### **7.2.2 MIDI**

When at the main Edit Menu, pressing this switch will select and move through the MIDI Menu.

### **7.2.3 NAMES**

When at the main Edit Menu, pressing this switch will select and move through the Names Menu.

### **7.2.4 PRESET**

When at the main Edit Menu, pressing this switch will select and move through the Preset Menu.

### **7.2.5 SONGSET**

When at the main Edit Menu, pressing this switch will select and move through the SongSet Menu.

### **7.2.6 UTILITY**

When at the main Edit Menu, pressing this switch will select and move through the Utility Menu.

### **7.2.7 0 – 9**

These switches are used to enter a numeric value for a parameter being edited.

### **7.2.8 SELECT**

This switch is used to move the cursor across the display when multiple parameters are shown. It's also used to switch/toggle between two different options for a parameter being edited.

### **7.2.9 ENTER ➡**

This switch is used to initiate/execute a process. It is also used to move/switch between different displays of a parameter being edited when there's a right-hand arrow shown on the display.

### **7.2.10 INC/NO & DEC/YES**

These switches are used to move/scroll through and select parameters to be edited or to enter alpha-numeric values and characters for other parameters, when held down these switches are repetitive accelerating. Alternatively they are also used to select "Y/N" when prompted on the display in some sub-menu's.

## 7.2 Secondary Switch Functions (Cont'd)

### 7.2.11 EXIT/SAVE

When at the main Edit Menu, pressing this switch will exit the Edit Mode.

When in one of the Edit Mode's six sub-menu's, pressing this switch will return to the main Edit Menu.

When in the PRST, SONG or one of the SET0 - SET9 Operating Modes, pressing an instant access switch will cause the LED above this switch to flash, indicating that the preset has been altered. There are now four options, all of which cause the LED above this switch to stop flashing.

1. Press the appropriate instant access switch(es) to return the preset to its original/stored state.
2. Press the active preset switch to recall and transmit its original/stored data. This can't be done with the Global Preset since there's no active preset switch when it's selected.
3. Select a different preset, either within the same bank/song or in another bank/song, this will discard the altered instant access switch settings and recall/transmit the new preset data.
4. Press this switch to update/save the preset with the new/altered ON/OFF instant access switch settings.

#### !!! ATTENTION !!!

The following applies only when in the SONG or one of the SET0 – SET9 Operating Modes. Since a song is a custom bank of the FX1's regular presets, which can be (and probably are) used in other songs, the FX1 will first check to see if the preset being updated is used in another song. If the preset is not used in another song, the FX1 will proceed with updating the preset at its current location. If the preset is used in another song, the FX1 will first copy and save the entire preset in the next available/blank preset location. Then it will make the necessary instant access switch ON/OFF status change(s) and finally it will update the song with the new preset location. The FX1 will automatically rename the new preset in the following format.

a b c d e f g h i j k l m n o p



- e and f on the display indicate the song number (01 to 99).
- h indicates the preset number (1 to 6 or 0 for the Global Preset) in the song.
- j and k indicate the bank number (01 to 21) that the original preset is located in.
- m refers to the original preset (1 to 6 or 0 for the Global Preset) in the above bank.

If there are no more blank preset locations, pressing this switch to update the preset will not do anything and the LED above this switch will continue to flash, indicating and confirming that there are no more blank presets available.

## 8. Rear Panel



### 8.1.1 *XPDL:1*

This is a standard ¼" TRS (stereo) jack and it allows an external expression pedal (or a switch) to be connected to the FX1. The ring and sleeve of this jack are internally protected with resistors so that a short circuit will not damage the port input circuitry and/or the FX1. Pedal resistance isn't critical, but please see Sections 17.1.1 to 17.1.3 : Cables and Section 16.5 : XP1 – XP4 Port Calibration more information on using this jack.

### 8.1.2 *XPDL:2*

Same as above.

### 8.1.3 *XPDL:3*

Same as above.

### 8.1.4 *XPDL:4*

Same as above.

### 8.1.5 *S11:S12*

This is a standard ¼" TRS (stereo) jack and it allows two external "normally open momentary switches" to be connected in parallel to the FX1's **S11** (tip – sleeve) and **S12** (ring – sleeve) instant access switches. The purpose of this jack is to provide the option of positioning one or two footswitches where it is more convenient for certain things such as a tap tempo switch, a hold switch... Please see Sections 17.1.4 to 17.1.7 : Cables for more information on using this jack.

## 8. Rear Panel (Cont'd)

### 8.1.6 9VAC:0.4A

This is a standard 5.5mm/2.1mm barrel jack and it allows the FX1 to receive power. The FX1's power requirements are 9Vac @ 400mA (0.4A). The power adapter shipped with the FX1 is capable of supplying 9Vac @ 1000mA which is more than enough to power two FX1's (in a Master/Slave Loop). **!!! Do NOT use this jack if the FX1 is receiving phantom power via the MIDI IN, the MIDI OUT or the TO RACK jack – the FX1 should receive power from ONLY ONE source !!!**

### 8.1.7 MIDI IN

This is a standard 5-pin DIN jack and it allows the FX1 to receive MIDI information and commands such as control change, program change and system exclusive messages from external MIDI devices such as a sequencer, a computer, another FX1 or another MIDI footcontroller (see Section 16.7, Section 18 and Section 19 for details on its use). Pins 1 and 3 can provide phantom power to the FX1 from another device or a remote location.

### 8.1.8 MIDI OUT

This is a standard 5-pin DIN jack and it allows the FX1 to transmit MIDI information/commands to external MIDI devices. Pins 1 and 3 can provide phantom power to the FX1 from another device or a remote location.

### 8.1.9 TO RACK

This is a heavy-duty (locking) 5-pin (male) XLR jack and it allows the FX1 to transmit MIDI information/commands to external MIDI devices. Pinout - [1] 9Vac [2] n/c [3] 9Vac [4] MIDI Out Pin#4 [5] MIDI Out Pin #5 [S] Shield/Ground.

*Please note that the MIDI OUT jack transmits a continuous MIDI system exclusive message for use when two or more FX1's are connected in a Master/Slave Loop. If this continuous stream of MIDI data causes noise in a receiving MIDI device, using the TO RACK jack will eradicate the noise because it doesn't transmit the above stream of data.*

### 8.1.10 EXPANDER

This is a heavy-duty (locking) 5-pin (male) XLR jack and it allows the FX1 to communicate with and supply power to the optional instant access switch expander. **!!! Only connect the FX1 and expander when the FX1 is OFF !!!**

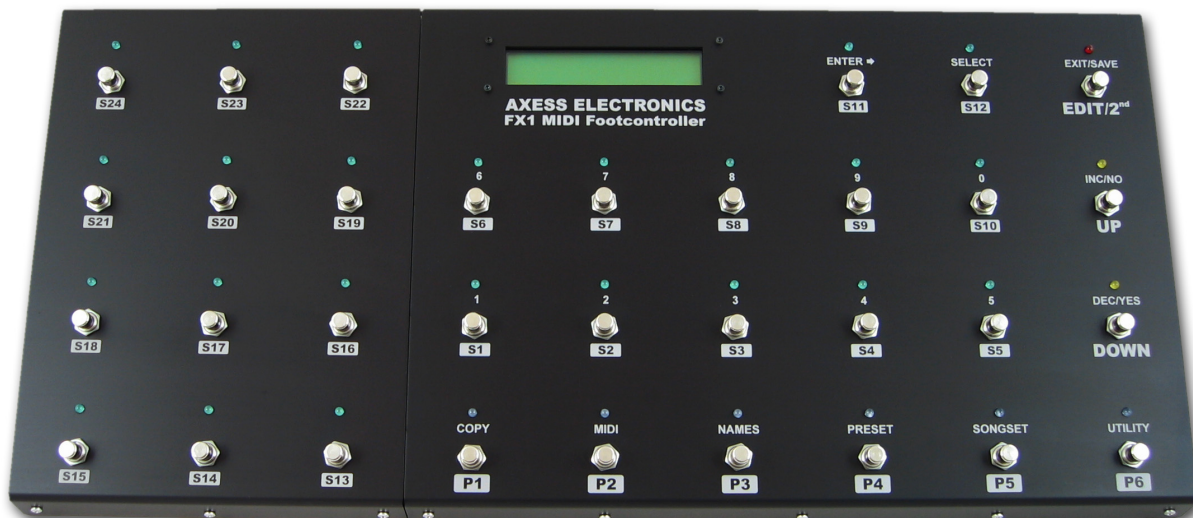

## 9. Power On

When power is first applied to the FX1, all of its LED's (and those on the expander – if connected) will remain OFF and the display will show the current software version number for two seconds, as follows (the actual version number may differ depending on when this manual was published).

a b c d e f g h i j k l m n o p

A 16x2 LCD display showing the text "FX1 Version 1.00" in a pixelated font. The characters are centered on the screen.

The display will then go blank (very briefly) before starting the Liquid Crystal Display (LCD) display test which is comprised of an “all pixels on” character scrolling from left to right, across the display. As the “all pixels on” character scrolls from left to right, the following message will be left behind.

a b c d e f g h i j k l m n o p

A 16x2 LCD display showing the text "FX1 LED Test..." in a pixelated font. The characters are centered on the screen.

At which point all the FX1 LED's (and those on the expander – if connected) will turn ON for two seconds.

After the two second LED test is over, the FX1 will automatically return to the operating mode, bank/song and preset that was active when it was last powered off, whether intentional or not...

To immediately abort the above tests, simply press any switch on the FX1.

When an FX1 is setup for the SLAV Operating Mode, the following message ...

a b c d e f g h i j k l m n o p

A 16x2 LCD display showing the text "No !MasterSwsex!" in a pixelated font. The characters are centered on the screen.

... will be displayed after the above tests have finished if the slaved FX1 is not properly connected to a master FX1.



# 10. Edit Mode

To enter the Edit Mode, press and hold the **EDIT/2<sup>nd</sup>** switch for 1 second. All the LED's will turn OFF, except the **EDIT/2<sup>nd</sup>** LED and the **P1** to **P6** LED's which will start flashing. The display will show (the following Edit Menu).

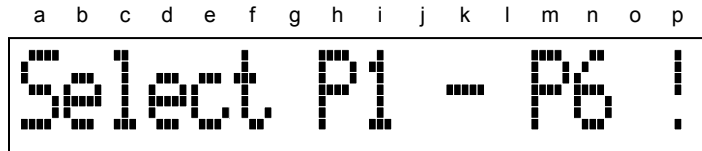

As the display suggests...

- Press the **COPY (P1)** switch to enter the Copy Menu.
- Press the **MIDI (P2)** switch to enter the MIDI Menu.
- Press the **NAMES (P3)** switch to enter the Names Menu.
- Press the **PRESET (P4)** switch to enter the Preset Menu.
- Press the **SONGSET (P5)** switch to enter the SongSet Menu.
- Press the **UTILITY (P6)** switch to enter the Utility Menu.
- Press the **EXIT / SAVE (EDIT / 2<sup>nd</sup>)** switch to exit the Edit Mode.

The Copy Menu allows copying entire presets, banks of presets, songs, setlists and instant access switches from one location to another.

The MIDI Menu allows defining global parameters such as; the MIDI channel that the FX1 will respond to incoming MIDI messages on, the starting number used when displaying program change messages, the control change and program change messages that each instant access switch will transmit, the control change message each internal control change will transmit, the expression pedal ports control change settings and the custom hex/MIDI messages of each instant access switch.

The Names Menu allows custom names to be created/edited for each song, setlist, MIDI channel, instant access switch and internal control change.

The Preset Menu allows selecting a preset, assigning it a custom 13 character name and up to 16 program change messages for it to transmit. The on/off status of the instant access switches and internal control changes, determining how the expression pedal ports will function when used in the preset and assigning a custom hex/MIDI message to be sent as part of the preset are also handled in this menu.

The SongSet Menu allows for the FX1's regular presets to be organized in a custom bank to create a song. Multiple songs can then be arranged into a collection of customs banks (each bank represents a song) to create a setlist.

The Utility Menu allows configuring the FX1's general functionality by selecting its operating mode and defining how the preset switches, instant access switches and expression ports will function when used. Its sub-menu's also provide access to the user data/dump, delete/restore, expression pedal port calibration and firmware update utilities.

*Please note that when in one of the Edit Mode's six sub-menu's (listed above), some of the switches will not perform their (secondary) function until a complete number has been entered for the parameter being edited – this is normal.*

# 11. Copy Menu

The Copy Menu allows copying entire presets, banks of presets, songs, setlists and instant access switches from one location to another.

## 11.1 Preset Copy

This sub-menu allows copying a preset from one preset location to another.

From the Edit Menu, press the **COPY** switch one time, the display will show.

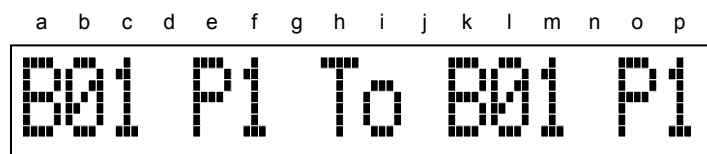

- b, c and f on the display indicate the preset (and the bank it's in) that is going to be copied.
- l, m and p on the display indicate the destination preset location (and the bank it's in) to copy to.

The LED above the following switches will turn ON indicating the switches can be used while in this sub-menu.

**EXIT/SAVE** Press to return to the Edit Menu (nothing will be copied).

**SELECT** Press to move the cursor from left to right (and back) between the banks and presets.

**NAMES** Press/hold to display the user assigned name for a preset and release to return to the above display format. When the cursor is at display locations b, c or f, pressing/holding this switch will display the name assigned to the preset that is going to be copied. When the cursor is at display locations l, m or p, pressing/holding this switch will display the name currently assigned to the destination preset that is going to be copied to.

**COPY** Press to advance to the next Copy sub-menu (nothing will be copied). The LED above this switch will always flash as a reminder that a Copy sub-menu is selected.

**0 – 9** Press one switch to enter a preset number between 1 & 6 or 0 (for the Global Preset) and press two switches to enter a bank number between 01 & 21. When the cursor is at one of the preset locations the LED above switches **7**, **8** and **9** will turn OFF since there are no such presets.

**ENTER →** Press to begin the copying process. While the FX1 is copying a preset, the display will show.

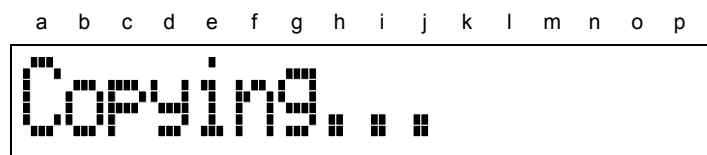

After the copying process is complete the display will be updated with the bank and preset numbers that were shown when first entering this sub-menu.

## 11.2 Bank Copy

This sub-menu allows copying an entire bank of six presets to another bank.

From the Edit Menu, press the **COPY** switch two times, the display will show.

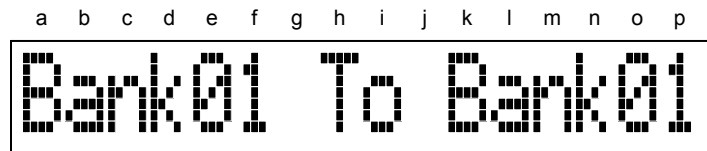

- e and f on the display indicate the bank that is going to be copied.
- o and p on the display indicate the destination bank location to copy to.

The LED above the following switches will turn ON indicating the switches can be used while in this sub-menu.

**SELECT** Press to move the cursor between the two banks.

**EXIT/SAVE** Press to return to the Edit Menu (nothing will be copied).

**0 – 9** Press two switches to enter a bank number between 01 & 21.

**COPY** Press to advance to the next Copy sub-menu (nothing will be copied). The LED above this switch will always flash as a reminder that a Copy sub-menu is selected.

**ENTER →** Press to begin the copying process. While the FX1 is copying a bank, the display will show.

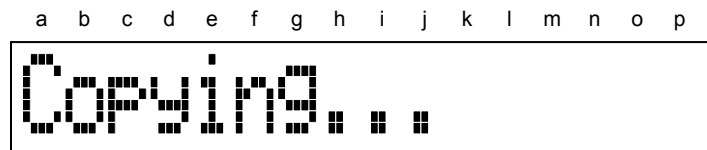

After the copying process is complete the display will be updated with the bank numbers that were shown when first entering this sub-menu.

## 11.3 Song Copy

This sub-menu allows copying a song from one song location to another.

From the Edit Menu, press the **COPY** switch three times, the display will show.

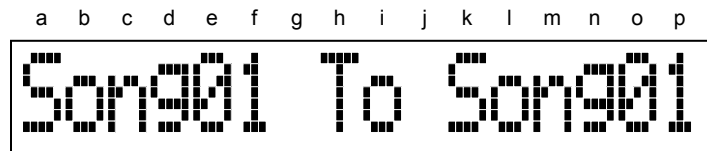

- e and f on the display indicate the song that is going to be copied.
- o and p on the display indicate the destination song location to copy to.

The LED above the following switches will turn ON indicating the switches can be used while in this sub-menu.

**SELECT** Press to move the cursor between the two songs.

**EXIT/SAVE** Press to return to the Edit Menu (nothing will be copied).

**0 – 9** Press two switches to enter a song number between 01 & 99.

**NAMES** Press/hold to display the user assigned name for a song and release to return to the above display format. When the cursor is at display locations e or f, pressing/holding this switch will display the name assigned to the song that is going to be copied. When the cursor is at display locations o or p, pressing/holding this switch will display the name currently assigned to the destination song that is going to be copied to.

**COPY** Press to advance to the next Copy sub-menu (nothing will be copied). The LED above this switch will always flash as a reminder that a Copy sub-menu is selected.

**ENTER →** Press to begin the copying process. While the FX1 is copying a song, the display will show.

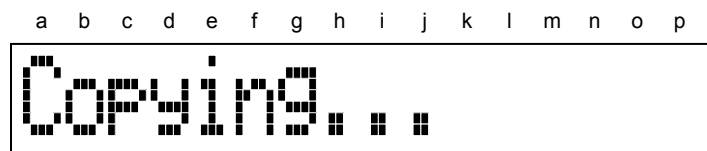

After the copying process is complete the display will be updated with the song numbers that were shown when first entering this sub-menu.

## 11.4 Setlist Copy

This sub-menu allows copying a setlist from one setlist location to another.

From the Edit Menu, press the **COPY** switch four times, the display will show.

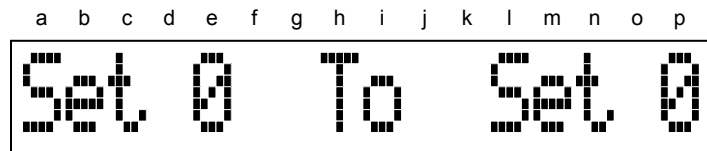

- e on the display indicates the setlist that is going to be copied.
- p on the display indicates the destination setlist location to copy to.

The LED above the following switches will turn ON indicating the switches can be used while in this sub-menu.

**SELECT** Press to move the cursor between the two setlists.

**EXIT/SAVE** Press to return to the Edit Menu (nothing will be copied).

**0 – 9** Press one switch to enter a setlist number between 0 & 9.

**NAMES** Press/hold to display the user assigned name for a setlist and release to return to the above display format. When the cursor is at display location e, pressing/holding this switch will display the name assigned to the setlist that is going to be copied. When the cursor is at display location p, pressing/holding this switch will display the name currently assigned to the destination setlist that is going to be copied to.

**COPY** Press to advance to the next Copy sub-menu (nothing will be copied). The LED above this switch will always flash as a reminder that a Copy sub-menu is selected.

**ENTER →** Press to begin the copying process. While the FX1 is copying a setlist, the display will show.

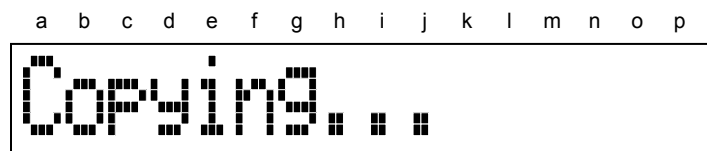

After the copying process is complete the display will be updated with the setlist numbers that were shown when first entering this sub-menu.

## 11.5 Instant Access Switch Copy

This sub-menu allows copying the MIDI data of one instant access switch to another instant access switch.

From the Edit Menu, press the **COPY** switch five times, the display will show.

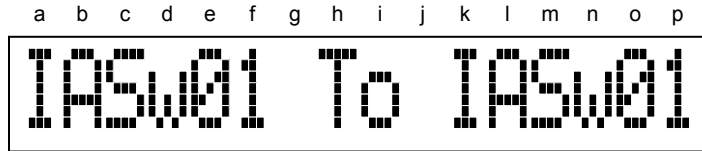

- e and f on the display indicate the instant access switch that is going to be copied.
- o and p on the display indicate the destination instant access switch location to copy to.

The LED above the following switches will turn ON indicating the switches can be used while in this sub-menu.

**EXIT/SAVE** Press to return to the Edit Menu (nothing will be copied).

**SELECT** Press to move the cursor between the two instant access switches.

**0 – 9** Press two switches to enter an instant access switch number between 01 & 24.

**COPY** Press to return to the first Copy sub-menu (nothing will be copied). The LED above this switch will always flash as a reminder that a Copy sub-menu is selected.

**NAMES** Press/hold to display the user assigned name for an instant access switch and release to return to the above display format. When the cursor is at display locations e or f, pressing/holding this switch will display the name assigned to the instant access switch that is going to be copied. When the cursor is at display locations o or p, pressing/holding this switch will display the name currently assigned to the destination instant access switch that is going to be copied to.

**ENTER →** Press to begin the copying process. While the FX1 is copying an instant access switch, the display will show.

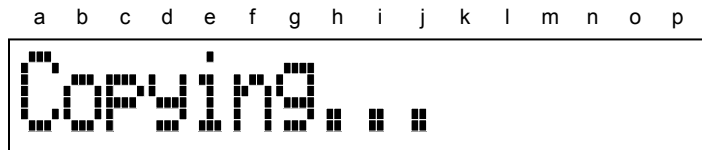

After the copying process is complete the display will be updated with the instant access switch numbers that were shown when first entering this sub-menu.

*Only instant access switches **S1 - S12** are capable of sending a custom 16 byte hex message. So if/when copying instant access switch **S1 - S12** to **S13 - S24** the custom 16 byte hex message can't be copied. Alternatively, when copying instant access switch **S13 - S24** to **S1 - S12** there is no custom 16 byte hex message to be copied, so if there is a pre-existing custom 16 byte hex message at the destination instant access switch location, it'll be deleted.*

# 12. MIDI Menu

The MIDI Menu allows defining global parameters such as; the MIDI channel that the FX1 will respond to incoming MIDI messages on, the starting number used when displaying program change messages, the control change and program change messages that each instant access switch will transmit, the control change message each internal control change will transmit, the expression pedal ports control change settings and the custom hex/MIDI messages of each instant access switch.

## 12.1 Receive MIDI Channel

This sub-menu allows setting the MIDI channel that incoming MIDI control change and/or program change messages must be on in order for banks/songs and presets to be selected from a remote device (such as a sequencer) when the FX1 is in the PRST, SONG and SET0 – SET9 Operating Modes.

From the Edit Menu, press the **MIDI** switch one time, the display will show.

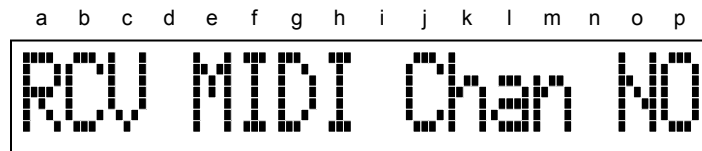

- o and p indicate the MIDI channel that the FX1 will receive MIDI messages on (01 to 16 or NO).

The LED above the following switches will turn ON indicating the switches can be used while in this sub-menu.

- EXIT/SAVE** Press to return to the Edit Menu, any changes made while in this sub-menu will automatically be saved.
- MIDI** Press to advance to the next MIDI sub-menu, any changes made while in this sub-menu will automatically be saved. The LED above this switch will always flash as a reminder that a MIDI sub-menu is selected.
- 0 – 9** Press two switches to enter a MIDI channel number between 01 & 16 or 99 to stop the FX1 from responding to incoming MIDI control change and/or program change messages. Entering 99 will display NO instead of 99.
- NAMES** Press/hold to display the user assigned name for the MIDI channel and release to return to the above display format. When NO is displayed for the MIDI channel, the LED above this switch will turn OFF since there is no name to view.

## 12.2 Program Change Starting Number

This sub-menu allows setting the starting number (000 or 001) that the FX1 will use to display MIDI program change numbers for each MIDI channel. Some MIDI devices/processors display presets starting at 000 (and ending at 127) and others start at 001 (and end at 128). This sub-menu will ensure that the MIDI program change numbers shown on the FX1 display will match those on the MIDI device/processor display.

From the Edit Menu, press the **MIDI** switch two times, the display will show.

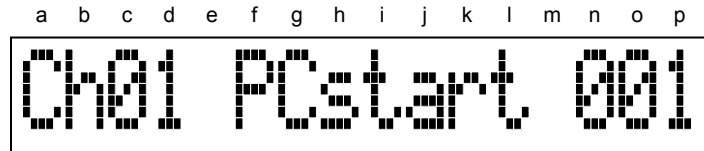

- c and d on the display indicate the MIDI channel (01 to 16).
- n to p on the display indicate the MIDI program change starting number (000 or 001).

The LED above the following switches will turn ON indicating the switches can be used while in this sub-menu.

**INC & DEC** Press/hold to move/scroll through the 16 MIDI channels.

**EXIT/SAVE** Press to return to the Edit Menu, any changes made while in this sub-menu will automatically be saved.

**MIDI** Press to advance to the next MIDI sub-menu, any changes made while in this sub-menu will automatically be saved. The LED above this switch will always flash as a reminder that a MIDI sub-menu is selected.

**NAMES** Press/hold to display the user assigned name for the MIDI channel and release to return to the above display format.

**0 & 1** Press either switch to change/select the MIDI program change starting number (000 or 001) for the displayed MIDI channel.



## 12.3 S1 – S24 Control & Program Changes

This sub-menu allows assigning two MIDI control change messages and two MIDI program change messages (one when the switch is ON and one when the switch is OFF) on individually selectable MIDI channels, for the twenty-four instant access switches. The control value for the MIDI control change messages is fixed at 0 = OFF and 127 = ON.

From the Edit Menu, press the **MIDI** switch three times, the display will show.

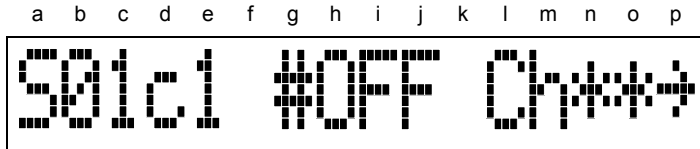

- b and c on the display will always indicate the instant access switch (01 to 24) while in this sub-menu.
- d on the display indicates the data shown is for a MIDI control change message (hence the lowercase c).
- e on the display indicates it's the 1<sup>st</sup> (of two) MIDI control change messages the instant access switch can send.
- h to j on the display indicate the MIDI control change number (000 to 127).
- n and o on the display will always indicate the MIDI channel (01 to 16 or \*\*) that the displayed MIDI message (at display locations h to j) will be sent on while in this sub-menu.

Press the **ENTER** → switch and the display will show.

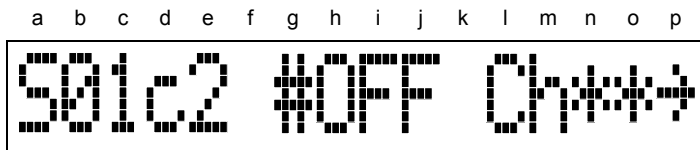

- e on the display indicates it's the 2<sup>nd</sup> (of two) MIDI control change messages the instant access switch can send.

Press the **ENTER** → switch and the display will show.

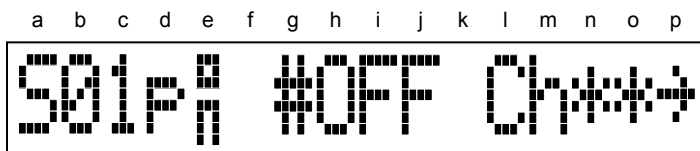

- d on the display indicates the data shown is for a MIDI program change message (hence the lowercase p).
- e on the display indicates it's the MIDI program change message the instant access switch will transmit when the instant access switch is ON.
- h to j on the display indicate the MIDI program change number (000 to 127 or 001 to 128 depending on the MIDI Program Change Start setting of the displayed MIDI channel).

Press the **ENTER** → switch and the display will show.

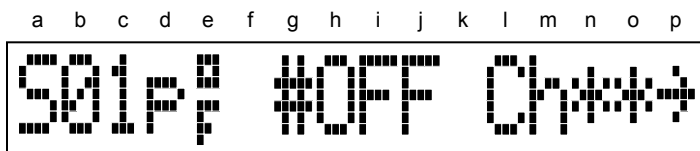

- e on the display indicates it's the MIDI program change message the instant access switch will transmit when the instant access switch is OFF.

Press the **ENTER** → switch again to return to the top...

## **12.3 S1 – S24 Ctl. & Pgm. Changes (Cont'd)**

The LED above the following switches will turn ON indicating the switches can be used while in this sub-menu.

- INC & DEC**      Press/hold to move/scroll through the 24 instant access switches.
- EXIT/SAVE**      Press to return to the Edit Menu, any changes made while in this sub-menu will automatically be saved.
- MIDI**              Press to advance to the next MIDI sub-menu, any changes made while in this sub-menu will automatically be saved. The LED above this switch will always flash as a reminder that a MIDI sub-menu is selected.
- ENTER →**        Press to move through the MIDI control change and MIDI program change messages that each instant access switch is capable of transmitting.
- 0 – 9**              Press two switches to enter a MIDI channel number between 01 & 16, press three switches to enter a MIDI control change number between 000 & 127 and press three switches to enter a MIDI program change number between 000 & 127 or 001 & 128 (depending on the MIDI Program Change Start setting for the MIDI channel shown). Entering 999 will stop the FX1 from transmitting the MIDI control change or MIDI program change message and the MIDI channel will automatically be changed to two asterisks. Entering 999 will display OFF instead of 999.
- NAMES**            Press/hold to display the user assigned name for the instant access switch or the MIDI channel and release to return. When the cursor is at display locations h, i or j, pressing/holding this switch will display the name assigned to the instant access switch. When the cursor is at display locations n or o, pressing/holding this switch will display the name assigned to the MIDI channel.
- SELECT**            Press to move the cursor between the MIDI control change or MIDI program change number and the MIDI channel, depending on what is shown on the display. The LED above this switch will turn OFF when OFF is displayed for the MIDI control change or MIDI program change number.

## 12.4 Internal Control Changes

This sub-menu allows assigning the MIDI control change and MIDI channel numbers for the twenty-four internal control change messages that can be sent as part of a preset. The control value for these MIDI control change messages is fixed at 0 = OFF and 127 = ON.

From the Edit Menu, press the **MIDI** switch four times, the display will show.

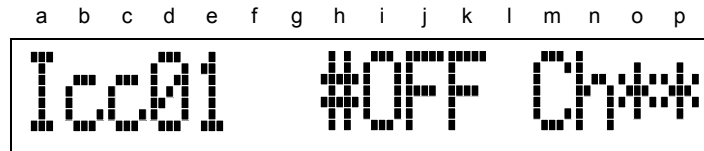

- d and e indicate the internal control change (01 to 24).
- i to k indicate the MIDI control change number (000 to 127).
- o and p on the display indicate the MIDI channel (01 to 16 or \*\*).

The LED above the following switches will turn ON indicating the switches can be used while in this sub-menu.

**INC & DEC** Press/hold to move/scroll through the 24 internal control changes.

**EXIT/SAVE** Press to return to the Edit Menu, any changes made while in this sub-menu will automatically be saved.

**MIDI** Press to advance to the next MIDI sub-menu, any changes made while in this sub-menu will automatically be saved. The LED above this switch will always flash as a reminder that a MIDI sub-menu is selected.

**NAMES** Press/hold to display the user assigned name for the internal control change or the MIDI channel and release to return to the above display format. When the cursor is at display locations i, j, or k, pressing/holding this switch will display the name assigned to the internal control change. When the cursor is at display locations o or p, pressing/holding this switch will display the name assigned to the MIDI channel.

**0 - 9** Press two switches to enter a MIDI channel number between 01 & 16 and press three switches to enter a MIDI control change number between 000 & 127. Entering 999 will stop the FX1 from transmitting the MIDI control change message and the MIDI channel will automatically be changed to two asterisks. Entering 999 will display OFF instead of 999.

**SELECT** Press to move the cursor between the MIDI control change number and the MIDI channel. The LED above this switch will turn OFF when OFF is displayed for the MIDI control change number.

*Internal Control Changes are simply twenty-four (24) more on/off MIDI control change messages that the FX1 can transmit as part of a preset. Unlike the Instant Access Switches which can be turned on or off for any given preset via a physical switch, the on/off status of the Internal Control Changes can only be changed while in the Edit Mode (see Section 14.5 : Internal Control Change On/Off Status for details).*

## 12.5 XP1 – XP4 Global Settings

This sub-menu allows assigning the global settings (MIDI control change number, MIDI channel, minimum, maximum and beginning MIDI control values) for the four expression pedal ports.

From the Edit Menu, press the **MIDI** switch five times, the display will show.

a b c d e f g h i j k l m n o p  
XP1 C#OFF C#\*\*➔

- c on the display indicates the expression pedal port (1 to 4).
- h to j indicate the MIDI control change number (000 to 127 or OFF).
- n and o on the display indicate the MIDI channel number (01 to 16 or \*\*).

Press the **ENTER** ➔ switch and the display will show.

a b c d e f g h i j k l m n o p  
XP1 BegValu 127➔

- m to o on the display indicate the initial MIDI control change value (000 to 127, OFF or PDL) that the expression pedal port will send when a preset is first selected.

Press the **ENTER** ➔ switch and the display will show.

a b c d e f g h i j k l m n o p  
XP1 MinValu 000➔

- m to o on the display indicate the lowest MIDI control change value (000 to 127) that the expression pedal port can send when its pedal/switch is moved/pressed.

Press the **ENTER** ➔ switch and the display will show.

a b c d e f g h i j k l m n o p  
XP1 MaxValu 127➔

- m to o on the display indicate the highest MIDI control change value (000 to 127) that the expression pedal port can send when its pedal/switch is moved/pressed.

Press the **ENTER** ➔ switch again to return to the top...

## 12.5 XP1 – XP4 Global Settings (Cont'd)

The LED above the following switches will turn ON indicating the switches can be used while in this sub-menu.

- INC & DEC** Press/hold to move/scroll through the 4 expression pedal ports.
- EXIT/SAVE** Press to return to the Edit Menu, any changes made while in this sub-menu will automatically be saved.
- MIDI** Press to advance to the next MIDI sub-menu, any changes made while in this sub-menu will automatically be saved. The LED above this switch will always flash as a reminder that a MIDI sub-menu is selected.
- NAMES** Press/hold to display the user assigned name for the MIDI channel shown on the display, and release to return to the above display format. The LED above this switch will turn OFF when two asterisks are displayed for the MIDI channel, which is the case when the displayed MIDI control change number is OFF.
- 0 – 9** Press two switches to enter a MIDI channel number between 01 & 16, press three switches to enter a MIDI control change number between 000 & 127 or 999, press three switches to enter a MIDI control change value between 000 & 127 for the MinValu and MaxValu, and press three switches to enter a MIDI control change value between 000 & 127, 444 or 999 for the BegValu. Entering 999 for the MIDI control change number will turn the expression pedal port off, and so Presets using the global setting for the expression pedal port will not transmit any MIDI data associated with the expression pedal port (the MIDI channel will automatically be changed to two asterisks). Entering 444 for the BegValu will cause the FX1 to transmit MIDI data corresponding to the actual pedal position when a preset is first selected. Entering 999 for the BegValu will cause the FX1 to NOT transmit any MIDI data associated with the expression pedal port when a preset is first selected, instead the FX1 will ONLY transmit the MIDI data associated with the expression pedal port when the pedal/switch connected to it is physically moved/pressed. Entering 444 will display PDL instead of 444 and entering 999 will display OFF instead of 999.
- SELECT** Press to move the cursor between the MIDI control change number and the MIDI channel. The LED above this switch will turn OFF when OFF is displayed for the MIDI control change number and when BegValu, MinValu or MaxValu are shown on the display.
- ENTER →** Press to move through the four parameters of the displayed expression pedal port.

*The MinValu must always be lower than the MaxValu and the MaxValu must always be higher than the MinValu.*

*The BegValu should never be lower than the MinValu and the BegValu should never be higher than the MaxValu.*

*When BegValu, MinValu and MaxValu are displayed, moving/pressing the pedal/switch connected to the displayed expression pedal port will also allow data entry of these three parameters.*

*Any changes made while in this sub-menu will result in the MIDI control change number and MIDI control change value being transmitted via the MIDI OUT and TO RACK jacks, in real-time.*

*When moving/pressing a pedal/switch for the first time after selecting a preset, the MIDI data associated with the expression pedal port will not be transmitted until the pedal/switch has crossed/reached the BegValu point. This will prevent an extreme change in the device/parameter (i.e. delay level, reverb level, volume level...) being controlled when the pedal/switch is moved/pressed. For example, if the BegValu is set to 100, moving the expression pedal will not have an effect until the pedal has crossed/reached the 100 BegValu position, at which point the device/parameter being controlled will track the movement of the expression pedal in real-time.*

*If the BegValu is set to PDL, the MIDI data corresponding to the actual pedal position will be transmitted when a preset is selected.*

*If the BegValu is set to OFF, the MIDI data associated with the expression pedal port will ONLY be transmitted when the pedal/switch connected to it is physically moved/pressed, nothing will be sent when a preset is selected.*

## 12.6 S1 – S12 Custom Hex/MIDI Message

This sub-menu allows creating two custom 16 byte hex / MIDI messages for instant access switches **S1** to **S12**. One of these custom messages will be transmitted when the instant access switch is ON and the other will be transmitted when the switch is OFF.

When creating a custom hex / MIDI message, always start with the 1<sup>st</sup> byte.

Need help creating a custom hex / MIDI message ? Visit the FX1 page on our website and download the MIDI/Hex Calculator (PC) or the FX1 Editor (Mac/PC), which includes a calculator...

From the Edit Menu, press the **MIDI** switch six times, the display will show.

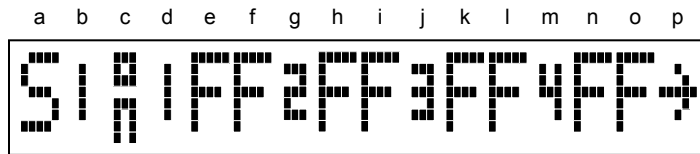

- b on the display will always indicate the instant access switch (1 to 12) while in this sub-menu.
- c on the display indicates it's the message the instant access switch will transmit when it is ON.
- d, g, j and m on the display indicate that these are the first four bytes of a custom hex message.

Press the **ENTER** → switch and the display will show.

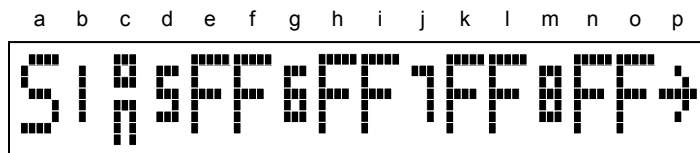

- d, g, j and m indicate that these are bytes 5 to 8 of a custom hex message.

Press the **ENTER** → switch and the display will show.

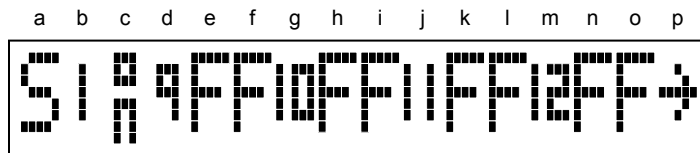

- d, g, j and m indicate that these are bytes 9 to 12 of a custom hex message.

Press the **ENTER** → switch and the display will show.

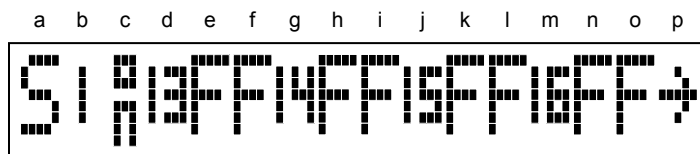

- d, g, j and m indicate that these are bytes 13 to 16 of a custom hex message.

Press the **ENTER** → switch and the display will show (continued on the next page).

## 12.6 S1 – S12 Custom Hex/MIDI Msg. (Cont'd)

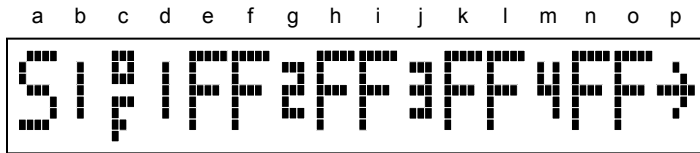

- c on the display indicates it's the message the instant access switch will transmit when it's OFF.
- d, g, j and m on the display indicate that these are the first four bytes of a custom hex message.

Press the **ENTER** → switch and the display will show.

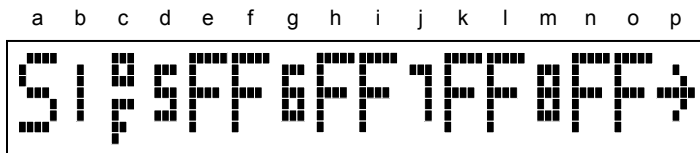

- d, g, j and m indicate that these are the bytes 5 to 8 of a custom hex message.

Press the **ENTER** → switch and the display will show.

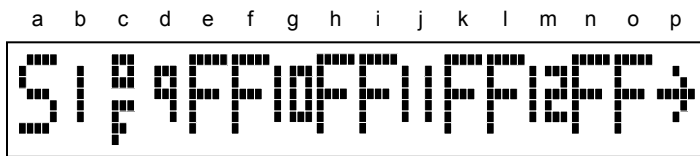

- d, g, j and m indicate that these are the bytes 9 to 12 of a custom hex message.

Press the **ENTER** → switch and the display will show.

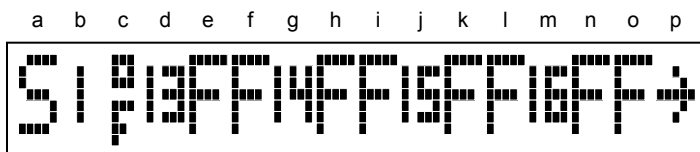

- d, g, j and m indicate that these are the bytes 13 to 16 of a custom hex message.

Press the **ENTER** → switch again to return to the top (first display on the previous page).

## 12.6 S1 – S12 Custom Hex/MIDI Msg. (Cont'd)

The LED above the following switches will turn ON indicating the switches can be used while in this sub-menu.

- NAMES** Press/hold to display the user assigned name for the instant access switch and release to return.
- EXIT/SAVE** Press to return to the Edit Menu, any changes made while in this sub-menu will automatically be saved.
- MIDI** Press to return to the first MIDI sub-menu, any changes made while in this sub-menu will automatically be saved. The LED above this switch will always flash as a reminder that a MIDI sub-menu is selected.
- ENTER →** Press to move through and display four bytes (at a time) of the instant access switch's ON and OFF custom 16 byte hex/MIDI messages.
- INC & DEC** Press/hold to move/scroll through the 12 instant access switches when the cursor is at display location b and press/hold to move/scroll through the sixteen hex characters (0 to 9 & A to F) available for each nibble (display locations e, f, h, i, k, l, n and o) when creating a custom hex message. Two nibbles equal one byte and vice-versa.
- SELECT** Press to move the cursor from left to right (and back) through the instant access switch number and the eight nibbles (display locations e, f, h, i, k, l, n and o).

### 12.6.1 MIDI Messages For Guitar Players 101

Guitar players only use a very small fraction of the messages (and features) that MIDI is capable of supporting. The two MIDI messages most commonly used by guitar players are control change messages and program change messages, so those are the one's details will be provided for here/below. For details on other MIDI messages, please go here [www.midi.org/about-midi/table1.shtml](http://www.midi.org/about-midi/table1.shtml) .

MIDI control change messages are generally used to turn audio loops and switching functions ON and OFF, either via an instant access switch or as part of a preset, on guitar audio/function switchers. A control change message is three bytes (six nibbles) long and looks like this;

Bn cc vv

MIDI program change messages are generally used to select presets/patches on rackmount effect processors. A program change message is two bytes (four nibbles) long and looks like this;

Cn pp

Nibble B informs the MIDI receiving device that the message is a control change message.

Nibble C informs the MIDI receiving device that the message is a program change message.

Nibble n refers to the MIDI channel that the control change or program change message is being sent on. To send a message on MIDI channel;

|                     |                     |                      |                      |
|---------------------|---------------------|----------------------|----------------------|
| #1 replace n with 0 | #5 replace n with 4 | #9 replace n with 8  | #13 replace n with C |
| #2 replace n with 1 | #6 replace n with 5 | #10 replace n with 9 | #14 replace n with D |
| #3 replace n with 2 | #7 replace n with 6 | #11 replace n with A | #15 replace n with E |
| #4 replace n with 3 | #8 replace n with 7 | #12 replace n with B | #16 replace n with F |



## 12.6 S1 – S12 Custom Hex/MIDI Msg. (Cont'd)

### 12.6.1 MIDI Messages For Guitar Players 101 (Cont'd)

Byte *cc* is the control change number. The MIDI specification allows 121 of them to be used freely, and different switcher manufacturers can/do use different numbers, so following is a complete list. To send control change;

|                               |                               |                               |                                |
|-------------------------------|-------------------------------|-------------------------------|--------------------------------|
| #0 replace <i>cc</i> with 00  | #31 replace <i>cc</i> with 1F | #62 replace <i>cc</i> with 3E | #93 replace <i>cc</i> with 5D  |
| #1 replace <i>cc</i> with 01  | #32 replace <i>cc</i> with 20 | #63 replace <i>cc</i> with 3F | #94 replace <i>cc</i> with 5E  |
| #2 replace <i>cc</i> with 02  | #33 replace <i>cc</i> with 21 | #64 replace <i>cc</i> with 40 | #95 replace <i>cc</i> with 5F  |
| #3 replace <i>cc</i> with 03  | #34 replace <i>cc</i> with 22 | #65 replace <i>cc</i> with 41 | #96 replace <i>cc</i> with 60  |
| #4 replace <i>cc</i> with 04  | #35 replace <i>cc</i> with 23 | #66 replace <i>cc</i> with 42 | #97 replace <i>cc</i> with 61  |
| #5 replace <i>cc</i> with 05  | #36 replace <i>cc</i> with 24 | #67 replace <i>cc</i> with 43 | #98 replace <i>cc</i> with 62  |
| #6 replace <i>cc</i> with 06  | #37 replace <i>cc</i> with 25 | #68 replace <i>cc</i> with 44 | #99 replace <i>cc</i> with 63  |
| #7 replace <i>cc</i> with 07  | #38 replace <i>cc</i> with 26 | #69 replace <i>cc</i> with 45 | #100 replace <i>cc</i> with 64 |
| #8 replace <i>cc</i> with 08  | #39 replace <i>cc</i> with 27 | #70 replace <i>cc</i> with 46 | #101 replace <i>cc</i> with 65 |
| #9 replace <i>cc</i> with 09  | #40 replace <i>cc</i> with 28 | #71 replace <i>cc</i> with 47 | #102 replace <i>cc</i> with 66 |
| #10 replace <i>cc</i> with 0A | #41 replace <i>cc</i> with 29 | #72 replace <i>cc</i> with 48 | #103 replace <i>cc</i> with 67 |
| #11 replace <i>cc</i> with 0B | #42 replace <i>cc</i> with 2A | #73 replace <i>cc</i> with 49 | #104 replace <i>cc</i> with 68 |
| #12 replace <i>cc</i> with 0C | #43 replace <i>cc</i> with 2B | #74 replace <i>cc</i> with 4A | #105 replace <i>cc</i> with 69 |
| #13 replace <i>cc</i> with 0D | #44 replace <i>cc</i> with 2C | #75 replace <i>cc</i> with 4B | #106 replace <i>cc</i> with 6A |
| #14 replace <i>cc</i> with 0E | #45 replace <i>cc</i> with 2D | #76 replace <i>cc</i> with 4C | #107 replace <i>cc</i> with 6B |
| #15 replace <i>cc</i> with 0F | #46 replace <i>cc</i> with 2E | #77 replace <i>cc</i> with 4D | #108 replace <i>cc</i> with 6C |
| #16 replace <i>cc</i> with 10 | #47 replace <i>cc</i> with 2F | #78 replace <i>cc</i> with 4E | #109 replace <i>cc</i> with 6D |
| #17 replace <i>cc</i> with 11 | #48 replace <i>cc</i> with 30 | #79 replace <i>cc</i> with 4F | #110 replace <i>cc</i> with 6E |
| #18 replace <i>cc</i> with 12 | #49 replace <i>cc</i> with 31 | #80 replace <i>cc</i> with 50 | #111 replace <i>cc</i> with 6F |
| #19 replace <i>cc</i> with 13 | #50 replace <i>cc</i> with 32 | #81 replace <i>cc</i> with 51 | #112 replace <i>cc</i> with 70 |
| #20 replace <i>cc</i> with 14 | #51 replace <i>cc</i> with 33 | #82 replace <i>cc</i> with 52 | #113 replace <i>cc</i> with 71 |
| #21 replace <i>cc</i> with 15 | #52 replace <i>cc</i> with 34 | #83 replace <i>cc</i> with 53 | #114 replace <i>cc</i> with 72 |
| #22 replace <i>cc</i> with 16 | #53 replace <i>cc</i> with 35 | #84 replace <i>cc</i> with 54 | #115 replace <i>cc</i> with 73 |
| #23 replace <i>cc</i> with 17 | #54 replace <i>cc</i> with 36 | #85 replace <i>cc</i> with 55 | #116 replace <i>cc</i> with 74 |
| #24 replace <i>cc</i> with 18 | #55 replace <i>cc</i> with 37 | #86 replace <i>cc</i> with 56 | #117 replace <i>cc</i> with 75 |
| #25 replace <i>cc</i> with 19 | #56 replace <i>cc</i> with 38 | #87 replace <i>cc</i> with 57 | #118 replace <i>cc</i> with 76 |
| #26 replace <i>cc</i> with 1A | #57 replace <i>cc</i> with 39 | #88 replace <i>cc</i> with 58 | #119 replace <i>cc</i> with 77 |
| #27 replace <i>cc</i> with 1B | #58 replace <i>cc</i> with 3A | #89 replace <i>cc</i> with 59 | #120 replace <i>cc</i> with 78 |
| #28 replace <i>cc</i> with 1C | #59 replace <i>cc</i> with 3B | #90 replace <i>cc</i> with 5A |                                |
| #29 replace <i>cc</i> with 1D | #60 replace <i>cc</i> with 3C | #91 replace <i>cc</i> with 5B |                                |
| #30 replace <i>cc</i> with 1E | #61 replace <i>cc</i> with 3D | #92 replace <i>cc</i> with 5C |                                |

Byte *vv* is the control change value and guitarists typically only use two, even though many exist. One value turns an audio loop or switching function ON and the other turns the audio loop or switching function OFF.

To turn an audio loop or switching function ON replace *vv* with 7F.

To turn an audio loop or switching function OFF replace *vv* with 00.

## 12.6 S1 – S12 Custom Hex/MIDI Msg. (Cont'd)

### 12.6.1 MIDI Messages For Guitar Players 101 (Cont'd)

Byte pp is the program change number. The MIDI specification allows 128 of them, so to send program change;

|                        |                        |                        |                         |
|------------------------|------------------------|------------------------|-------------------------|
| #0 replace pp with 00  | #32 replace pp with 20 | #64 replace pp with 40 | #96 replace pp with 60  |
| #1 replace pp with 01  | #33 replace pp with 21 | #65 replace pp with 41 | #97 replace pp with 61  |
| #2 replace pp with 02  | #34 replace pp with 22 | #66 replace pp with 42 | #98 replace pp with 62  |
| #3 replace pp with 03  | #35 replace pp with 23 | #67 replace pp with 43 | #99 replace pp with 63  |
| #4 replace pp with 04  | #36 replace pp with 24 | #68 replace pp with 44 | #100 replace pp with 64 |
| #5 replace pp with 05  | #37 replace pp with 25 | #69 replace pp with 45 | #101 replace pp with 65 |
| #6 replace pp with 06  | #38 replace pp with 26 | #70 replace pp with 46 | #102 replace pp with 66 |
| #7 replace pp with 07  | #39 replace pp with 27 | #71 replace pp with 47 | #103 replace pp with 67 |
| #8 replace pp with 08  | #40 replace pp with 28 | #72 replace pp with 48 | #104 replace pp with 68 |
| #9 replace pp with 09  | #41 replace pp with 29 | #73 replace pp with 49 | #105 replace pp with 69 |
| #10 replace pp with 0A | #42 replace pp with 2A | #74 replace pp with 4A | #106 replace pp with 6A |
| #11 replace pp with 0B | #43 replace pp with 2B | #75 replace pp with 4B | #107 replace pp with 6B |
| #12 replace pp with 0C | #44 replace pp with 2C | #76 replace pp with 4C | #108 replace pp with 6C |
| #13 replace pp with 0D | #45 replace pp with 2D | #77 replace pp with 4D | #109 replace pp with 6D |
| #14 replace pp with 0E | #46 replace pp with 2E | #78 replace pp with 4E | #110 replace pp with 6E |
| #15 replace pp with 0F | #47 replace pp with 2F | #79 replace pp with 4F | #111 replace pp with 6F |
| #16 replace pp with 10 | #48 replace pp with 30 | #80 replace pp with 50 | #112 replace pp with 70 |
| #17 replace pp with 11 | #49 replace pp with 31 | #81 replace pp with 51 | #113 replace pp with 71 |
| #18 replace pp with 12 | #50 replace pp with 32 | #82 replace pp with 52 | #114 replace pp with 72 |
| #19 replace pp with 13 | #51 replace pp with 33 | #83 replace pp with 53 | #115 replace pp with 73 |
| #20 replace pp with 14 | #52 replace pp with 34 | #84 replace pp with 54 | #116 replace pp with 74 |
| #21 replace pp with 15 | #53 replace pp with 35 | #85 replace pp with 55 | #117 replace pp with 75 |
| #22 replace pp with 16 | #54 replace pp with 36 | #86 replace pp with 56 | #118 replace pp with 76 |
| #23 replace pp with 17 | #55 replace pp with 37 | #87 replace pp with 57 | #119 replace pp with 77 |
| #24 replace pp with 18 | #56 replace pp with 38 | #88 replace pp with 58 | #120 replace pp with 78 |
| #25 replace pp with 19 | #57 replace pp with 39 | #89 replace pp with 59 | #121 replace pp with 79 |
| #26 replace pp with 1A | #58 replace pp with 3A | #90 replace pp with 5A | #122 replace pp with 7A |
| #27 replace pp with 1B | #59 replace pp with 3B | #91 replace pp with 5B | #123 replace pp with 7B |
| #28 replace pp with 1C | #60 replace pp with 3C | #92 replace pp with 5C | #124 replace pp with 7C |
| #29 replace pp with 1D | #61 replace pp with 3D | #93 replace pp with 5D | #125 replace pp with 7D |
| #30 replace pp with 1E | #62 replace pp with 3E | #94 replace pp with 5E | #126 replace pp with 7E |
| #31 replace pp with 1F | #63 replace pp with 3F | #95 replace pp with 5F | #127 replace pp with 7F |

# 13. Names Menu

The Names Menu allows custom names to be created/edited for each song, setlist, MIDI channel, instant access switch and internal control change.

## 13.1 Song Names

This sub-menu allows a custom name, up to 13 characters in length, to be created/modified for each of the FX1's 99 songs.

From the Edit Menu, press the **NAMES** switch one time, the display will show.

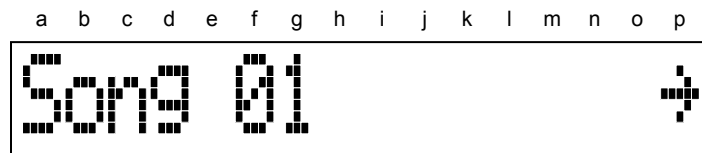

- f and g on the display indicate the song (01 to 99) for which a name is going to be created/modified.

The LED above the following switches will turn ON indicating the switches can be used while in this sub-menu.

- EXIT/SAVE** Press to return to the Edit Menu, any changes made while in this sub-menu will automatically be saved.
- INC & DEC** Press/hold to move/scroll through the 99 songs when the song number is displayed (as shown above) and press/hold to move/scroll through the available characters/fonts when the song name is displayed.
- NAMES** Press to advance to the next Names sub-menu, any changes made while in this sub-menu will automatically be saved. The LED above this switch will always flash as a reminder that a Names sub-menu is selected.
- ENTER →** Press to switch/toggle between displaying the song number (as shown above) and the song name being created/modified.
- SELECT** Press to move the cursor from left to right (and back) when creating/modifying the song name. The LED above this switch will only turn ON when the song name is displayed.

## 13.2 Setlist Names

This sub-menu allows a custom name, up to 13 characters in length, to be created/modified for each of the FX1's 10 setlists (SET0 – SET9 Operating Modes).

From the Edit Menu, press the **NAMES** switch two times, the display will show.

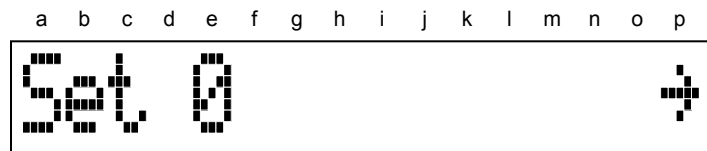

- e on the display indicates the setlist (0 to 9) for which a name is going to be created/modified.

The LED above the following switches will turn ON indicating the switches can be used while in this sub-menu.

**EXIT/SAVE** Press to return to the Edit Menu, any changes made while in this sub-menu will automatically be saved.

**INC & DEC** Press/hold to move/scroll through the 10 setlists when the setlist number is displayed (as shown above) and press/hold to move/scroll through the available characters/fonts when the setlist name is displayed.

**NAMES** Press to advance to the next Names sub-menu, any changes made while in this sub-menu will automatically be saved. The LED above this switch will always flash as a reminder that a Names sub-menu is selected.

**ENTER →** Press to switch/toggle between displaying the setlist number (as shown above) and the setlist name being created/modified.

**SELECT** Press to move the cursor from left to right (and back) when creating/modifying the setlist name. The LED above this switch will only turn ON when the setlist name is displayed.

## 13.3 MIDI Channel Names

This sub-menu allows a custom name, up to 14 characters in length, to be created/modified for each MIDI channel.

From the Edit Menu, press the **NAMES** switch three times, the display will show.

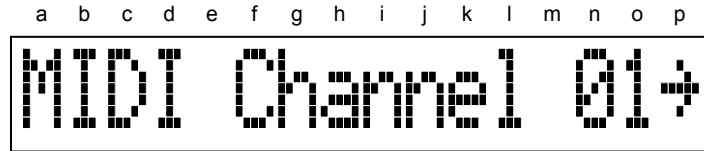

- n and o indicate the MIDI channel (01 to 16) for which a name is going to be created/modified.

The LED above the following switches will turn ON indicating the switches can be used while in this sub-menu.

**EXIT/SAVE** Press to return to the Edit Menu, any changes made while in this sub-menu will automatically be saved.

**NAMES** Press to advance to the next Names sub-menu, any changes made while in this sub-menu will automatically be saved. The LED above this switch will always flash as a reminder that a Names sub-menu is selected.

**INC & DEC** Press/hold to move/scroll through the 16 MIDI channels when the MIDI channel number is displayed (as shown above) and press/hold to move/scroll through the available characters/fonts when the MIDI channel name is displayed.

**ENTER →** Press to switch/toggle between displaying the MIDI channel number (as shown above) and the MIDI channel name being created/modified.

**SELECT** Press to move the cursor from left to right (and back) when creating/modifying the MIDI channel name. The LED above this switch will only turn ON when the MIDI channel name is displayed.

## 13.4 Instant Access Switch Names

This sub-menu allows a custom name, up to 14 characters in length, to be created/modified for each instant access switch.

From the Edit Menu, press the **NAMES** switch four times, the display will show.

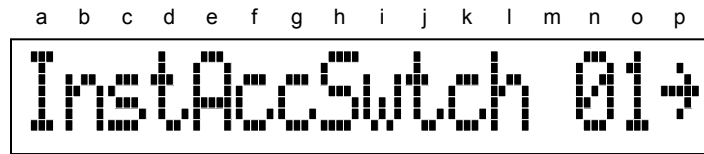

- n and o indicate the instant access switch (01 to 24) for which a name is going to be created/modified.

The LED above the following switches will turn ON indicating the switches can be used while in this sub-menu.

**EXIT/SAVE** Press to return to the Edit Menu, any changes made while in this sub-menu will automatically be saved.

**SELECT** Press to move the cursor from left to right (and back) when creating/modifying the instant access switch name. The LED above this switch will only turn ON when the instant access switch name is displayed.

**NAMES** Press to advance to the next Names sub-menu, any changes made while in this sub-menu will automatically be saved. The LED above this switch will always flash as a reminder that a Names sub-menu is selected.

**ENTER →** Press to switch/toggle between displaying the instant access switch number (as shown above) and the instant access switch name being created/modified.

**INC & DEC** Press/hold to move/scroll through the 24 instant access switches when the instant access switch number is displayed (as shown above) and press/hold to move/scroll through the available characters/fonts when the instant access switch name is displayed.

## 13.5 Internal Control Change Names

This sub-menu allows a custom name, up to 14 characters in length, to be created/modified for each internal control change.

From the Edit Menu, press the **NAMES** switch five times, the display will show.

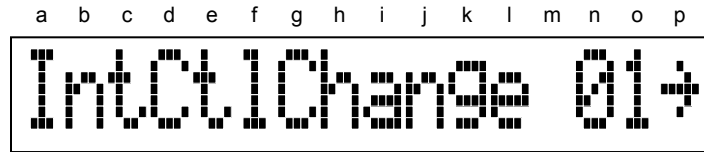

- n and o indicate the internal control change (01 to 24) for which a name is going to be created/modified.

The LED above the following switches will turn ON indicating the switches can be used while in this sub-menu.

**EXIT/SAVE** Press to return to the Edit Menu, any changes made while in this sub-menu will automatically be saved.

**SELECT** Press to move the cursor from left to right (and back) when creating/modifying the internal control change name. The LED above this switch will only turn ON when the internal control change name is displayed.

**NAMES** Press to return to the first Names sub-menu, any changes made while in this sub-menu will automatically be saved. The LED above this switch will always flash as a reminder that a Names sub-menu is selected.

**ENTER →** Press to switch/toggle between displaying the internal control change number (as shown above) and the internal control change name being created/modified.

**INC & DEC** Press/hold to move/scroll through the 24 internal control changes when the internal control change number is displayed (as shown above) and press/hold to move/scroll through the available characters/fonts when the internal control change name is displayed.

# 14. Preset Menu

The Preset Menu allows selecting a preset, assigning it a custom 13 character name and up to 16 program change messages for it to transmit. The on/off status of the instant access switches and internal control changes, determining how the expression pedal ports will function when used in the preset and assigning a custom hex/MIDI message to be sent as part of the preset are also handled in this menu.

## 14.1 Preset Select

This sub-menu allows selecting a preset to be created/modified.

From the Edit Menu, press the **PRESET** switch one time, the display will show.

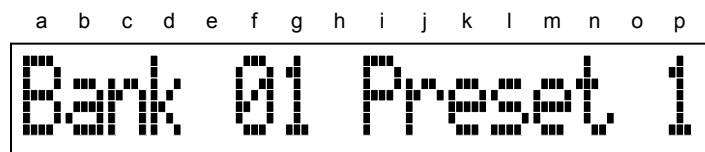

- f and g on the display indicate the bank number (01 to 21) that the preset is located in.
- p on the display indicates the preset (1 to 6 or 0 for the Global Preset) that is going to be created/modified.

*Please note that the preset selected in this sub-menu will be affected/modified by all the following Preset sub-menu's.*

*As an added convenience for preset selection and creation/modification, the preset (and the bank it's in) displayed when first entering this sub-menu will be the same preset selected prior to entering the Edit Mode from the PRST Operating Mode.*

*If the bank and/or preset values when first entering this sub-menu (from the Edit Mode) are changed, pressing the **PRESET** switch to advance through all the Preset sub-menu's and returning to this sub-menu, will result in the changed bank and/or preset values being displayed again.*

The LED above the following switches will turn ON indicating the switches can be used while in this sub-menu.

**EXIT/SAVE** Press to return to the Edit Menu.

**SELECT** Press to move the cursor between the bank number and the preset number.

**NAMES** Press/hold to display the user assigned name for the preset and release to return to the above display format.

**PRESET** Press to advance to the next Preset sub-menu (please note that the preset selected in this sub-menu will be affected/modified by all the following Preset sub-menu's). The LED above this switch will always flash as a reminder that a Preset sub-menu is selected.

**0 - 9** Press one switch to enter a preset number between 1 & 6 or 0 (for the Global Preset) and press two switches to enter a bank number between 01 & 21. When the cursor is at one of the preset locations the LED above switches **7**, **8** and **9** will turn OFF since there are no such presets.



## 14.2 Preset Name

This sub-menu allows a custom name, up to 13 characters in length, to be created/modified for the preset selected in the Preset Select sub-menu.

From the Preset Select sub-menu, press the **PRESET** switch one time. The display will show the name assigned to the preset selected in the Preset Select sub-menu. On a new FX1, the following name will be displayed for the preset shown on the previous page.

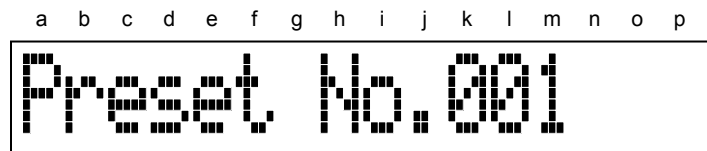

The LED above the following switches will turn ON indicating the switches can be used while in this sub-menu.

- SELECT**      Press to move the cursor from left to right (and back) when creating/modifying the preset name.
- INC & DEC**    Press/hold to move/scroll through the available characters/fonts when creating/modifying the preset name.
- EXIT/SAVE**    Press to return to the Edit Menu, any changes made while in this sub-menu will automatically be saved.
- PRESET**        Press to advance to the next Preset sub-menu, any changes made while in this sub-menu will automatically be saved. The LED above this switch will always flash as a reminder that a Preset sub-menu is selected.

## 14.3 Program Change Messages

This sub-menu allows assigning up to 16 MIDI program change messages (one for each MIDI channel) to the preset selected in the Preset Select sub-menu.

From the Preset Select sub-menu, press the **PRESET** switch two times, the display will show (on a new FX1).

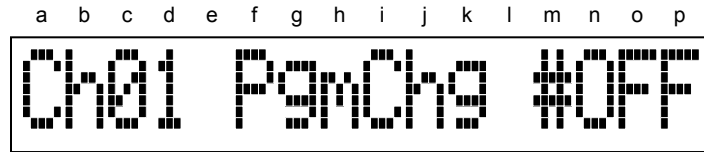

- c and d on the display indicate the MIDI channel (01 to 16).
- n to p on the display indicate the MIDI program change number (000 to 127 or 001 to 128 depending on the MIDI Program Change Start setting of the displayed MIDI channel).

The LED above the following switches will turn ON indicating the switches can be used while in this sub-menu.

**INC & DEC** Press/hold to move/scroll through the 16 MIDI channels.

**EXIT/SAVE** Press to return to the Edit Menu, any changes made while in this sub-menu will automatically be saved.

**NAMES** Press/hold to display the user assigned name for the MIDI channel and release to return to the above display format.

**PRESET** Press to advance to the next Preset sub-menu, any changes made while in this sub-menu will automatically be saved. The LED above this switch will always flash as a reminder that a Preset sub-menu is selected.

**0 – 9** Press three switches to enter a MIDI program change number between 000 & 127 or 001 & 128 (depending on the MIDI Program Change Start setting for the MIDI channel shown). Entering 999 will stop the FX1 from transmitting the MIDI program change message and the MIDI channel will automatically be changed to two asterisks. Entering 999 will display OFF instead of 999.

*Any changes made while in this sub-menu will result in the displayed MIDI program change message being transmitted via the MIDI OUT and TO RACK jacks.*

## 14.4 Instant Access Switch On/Off Status

This sub-menu allows the 24 instant access switches to be individually turned ON or OFF for the preset selected in the Preset Select sub-menu.

From the Preset Select sub-menu, press the **PRESET** switch three times, the display will show.

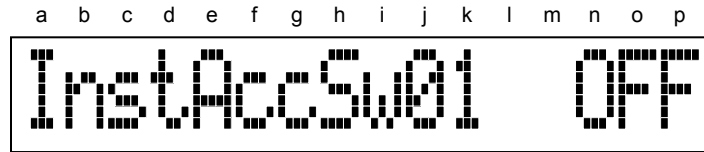

- j and k on the display indicate the instant access switch (01 to 24).
- n to p on the display indicate the instant access switch status (ON or OFF).

The LED above the following switches will turn ON indicating the switches can be used while in this sub-menu.

**INC & DEC** Press/hold to move/scroll through the 24 instant access switches.

**SELECT** Press to switch/toggle the instant access switch status ON and OFF.

**EXIT/SAVE** Press to return to the Edit Menu, any changes made while in this sub-menu will automatically be saved.

**PRESET** Press to advance to the next Preset sub-menu, any changes made while in this sub-menu will automatically be saved. The LED above this switch will always flash as a reminder that a Preset sub-menu is selected.

**NAMES** Press/hold to display the user assigned name for the instant access switch and release to return to the above display format.

*The ON/OFF status of the instant access switches can also be programmed without entering the Edit Mode (and this sub-menu) by simply selecting a preset, pressing the appropriate instant access switches to turn them ON or OFF, and pressing the **EXIT/SAVE** switch to store the settings.*

*Any changes made while in this sub-menu will result in the ON/OFF MIDI messages of the displayed instant access switch being transmitted via the MIDI OUT and TO RACK jacks.*

## 14.5 Internal Control Change On/Off Status

This sub-menu allows the 24 internal control change messages to be individually turned ON or OFF for the preset selected in the Preset Select sub-menu.

From the Preset Select sub-menu, press the **PRESET** switch four times, the display will show.

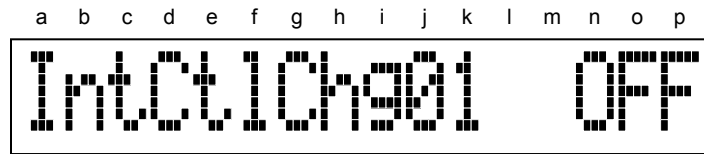

- j and k on the display indicate the internal control change (01 to 24).
- n to p on the display indicate the internal control change status (ON or OFF).

The LED above the following switches will turn ON indicating the switches can be used while in this sub-menu.

**INC & DEC** Press/hold to move/scroll through the 24 internal control changes.

**SELECT** Press to switch/toggle the internal control change status ON and OFF.

**EXIT/SAVE** Press to return to the Edit Menu, any changes made while in this sub-menu will automatically be saved.

**PRESET** Press to advance to the next Preset sub-menu, any changes made while in this sub-menu will automatically be saved. The LED above this switch will always flash as a reminder that a Preset sub-menu is selected.

**NAMES** Press/hold to display the user assigned name for the internal control change and release to return to the above display format.

*Any changes made while in this sub-menu will result in the ON/OFF MIDI control change message of the displayed internal control change being transmitted via the MIDI OUT and TO RACK jacks.*

## 14.6 XP1 – XP4 Preset Settings

This sub-menu allows setting how the four expression pedal ports will function for the preset selected in the Preset Select sub-menu. Each expression pedal port can be set to use its global settings or preset specific settings for MIDI control change number, MIDI channel, minimum, maximum and beginning MIDI control values.

From the Preset Select sub-menu, press the **PRESET** switch five times, the display will show.

a b c d e f g h i j k l m n o p  
XP1 C#GLO C#\*\*→

- c on the display indicates the expression pedal port (1 to 4).
- n and o on the display indicate the MIDI channel (01 to 16 or \*\*).
- h to j indicate the MIDI control change number (000 to 127 or GLO or OFF).

Press the **ENTER** → switch and the display will show.

a b c d e f g h i j k l m n o p  
XP1 BegValu 127→

- m to o on the display indicate the initial MIDI control change value (000 to 127) that the expression pedal port will send when the preset is first selected.

Press the **ENTER** → switch and the display will show.

a b c d e f g h i j k l m n o p  
XP1 MinValu 000→

- m to o on the display indicate the lowest MIDI control change value (000 to 127) that the expression pedal port can send when its pedal/switch is moved/pressed.

Press the **ENTER** → switch and the display will show.

a b c d e f g h i j k l m n o p  
XP1 MaxValu 127→

- m to o on the display indicate the highest MIDI control change value (000 to 127) that the expression pedal port can send when its pedal/switch is moved/pressed.

Press the **ENTER** → switch again to return to the top...

## 14.6 XP1 – XP4 Preset Settings (Cont'd)

The LED above the following switches will turn ON indicating the switches can be used while in this sub-menu.

- INC & DEC** Press/hold to move/scroll through the 4 expression pedal ports.
- ENTER →** Press to move through the four parameters of the displayed expression pedal port.
- EXIT/SAVE** Press to return to the Edit Menu, any changes made while in this sub-menu will automatically be saved.
- PRESET** Press to advance to the next Preset sub-menu, any changes made while in this sub-menu will automatically be saved. The LED above this switch will always flash as a reminder that a Preset sub-menu is selected.
- NAMES** Press/hold to display the user assigned name for the MIDI channel shown on the display, and release to return to the above display format. The LED above this switch will turn OFF when two asterisks are displayed for the MIDI channel, which is the case when the displayed MIDI control change number is GLO or OFF.
- SELECT** Press to move the cursor between the MIDI control change number and the MIDI channel. The LED above this switch will turn OFF when GLO or OFF is displayed for the MIDI control change number and when BegValu, MinValu or MaxValu are shown on the display.
- 0 – 9** Press two switches to enter a MIDI channel number between 01 & 16, press three switches to enter a MIDI control change number between 000 & 127 and press three switches to enter a MIDI control change value between 000 & 127 for the BegValu, MinValu and MaxValu. Entering 444 for the MIDI control change number will cause the FX1 to use the global settings for the expression pedal port when the preset is selected. Entering 999 for the MIDI control change number will turn the expression pedal port off. The preset will not transmit any MIDI data associated with the expression pedal port. Entering 444 will display GLO instead of 444 and entering 999 will display OFF instead of 999, in both cases the MIDI channel will automatically be changed to two asterisks.

*The MinValu must always be lower than the MaxValu and the MaxValu must always be higher than the MinValu.*

*The BegValu should never be lower than the MinValu and the BegValu should never be higher than the MaxValu.*

*When BegValu, MinValu and MaxValu are displayed, moving/pressing the pedal/switch connected to the displayed expression pedal port will also allow data entry of these three parameters.*

*Any changes made while in this sub-menu will result in the MIDI control change number and MIDI control change value being transmitted via the MIDI OUT and TO RACK jacks, in real-time.*

*When moving/pressing a pedal/switch for the first time after selecting a preset, the MIDI data associated with the expression pedal port will not be transmitted until the pedal/switch has crossed/reached the BegValu point (either this preset specific setting or the global setting). This will prevent an extreme change in the device/parameter (i.e. volume level...) being controlled when the pedal/switch is moved/pressed. For example, if the BegValu is set to 100, moving the expression pedal will not have an effect until the pedal has crossed/reached the 100 BegValu position, at which point the device/parameter being controlled will track the movement of the expression pedal in real-time.*

*When using an expression pedal port's global settings (Section 12.5 : XP1 – XP4 Global Settings) and the BegValu is set to OFF, the MIDI data associated with the expression pedal port will ONLY be transmitted when the pedal/switch connected to it is physically moved/pressed, nothing will be sent when a preset is selected. If the BegValu is set to PDL, the MIDI data corresponding to the actual pedal position will be transmitted when a preset is selected.*

## 14.7 Preset Custom Hex/MIDI Message

This sub-menu allows creating a custom 16 byte hex / MIDI message that will be sent as part of the preset that was selected in the Preset Select sub-menu.

When creating a custom hex / MIDI message, always start with the 1<sup>st</sup> byte.

Need help creating a custom hex / MIDI message ? Visit the FX1 page on our website and download the MIDI/Hex Calculator (PC only) or the FX1 Editor (both Mac/PC), which includes a built-in calculator...

From the Preset Select sub-menu, press the **PRESET** switch six times, the display will show.

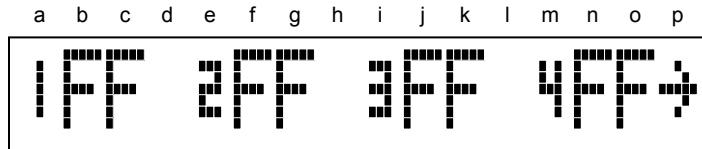

- a, e, i and m on the display indicate that these are bytes 1 to 4 of the custom hex message.

Press the **ENTER** → switch and the display will show.

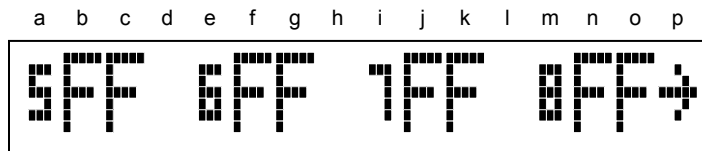

- a, e, i and m on the display indicate that these are bytes 5 to 8 of the custom hex message.

Press the **ENTER** → switch and the display will show.

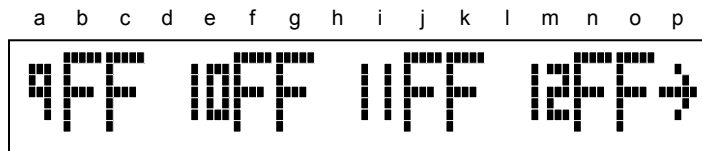

- a, e, i and m on the display indicate that these are bytes 9 to 12 of the custom hex message.

Press the **ENTER** → switch and the display will show.

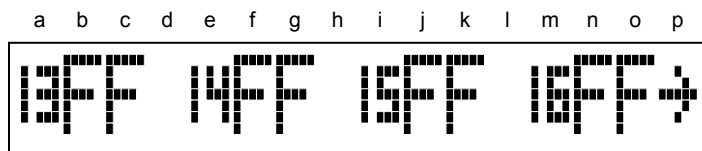

- a, e, i and m on the display indicate that these are bytes 13 to 16 of the custom hex message.

Press the **ENTER** → switch again to return to the top...

## 14.7 Preset Custom Hex/MIDI Msg. (Cont'd)

The LED above the following switches will turn ON indicating the switches can be used while in this sub-menu.

- ENTER →** Press to move through and display four bytes (at a time) of the custom 16 byte hex/MIDI message.
- EXIT/SAVE** Press to return to the Edit Menu, any changes made while in this sub-menu will automatically be saved.
- SELECT** Press to move the cursor from left to right (and back) through the eight nibbles (display locations b, c, f, g, j, k, n and o).
- PRESET** Press to return to the first Preset sub-menu, any changes made while in this sub-menu will automatically be saved. The LED above this switch will always flash as a reminder that a Preset sub-menu is selected.
- INC & DEC** Press/hold to move/scroll through the sixteen hex characters (0 to 9 & A to F) available for each nibble (display locations b, c, f, g, j, k, n and o) when creating the custom hex message. Two nibbles equal one byte and vice-versa.

### 14.7.1 MIDI Messages For Guitar Players 101

Guitar players only use a very small fraction of the messages (and features) that MIDI is capable of supporting. The two MIDI messages most commonly used by guitar players are control change messages and program change messages, so those are the one's details will be provided for here/below. For details on other MIDI messages, please go here [www.midi.org/about-midi/table1.shtml](http://www.midi.org/about-midi/table1.shtml) .

MIDI control change messages are generally used to turn audio loops and switching functions ON and OFF, either via an instant access switch or as part of a preset, on guitar audio/function switchers. A control change message is three bytes (six nibbles) long and looks like this;

Bn cc vv

MIDI program change messages are generally used to select presets/patches on rackmount effect processors. A program change message is two bytes (four nibbles) long and looks like this;

Cn pp

Nibble B informs the MIDI receiving device that the message is a control change message.

Nibble C informs the MIDI receiving device that the message is a program change message.

Nibble n refers to the MIDI channel that the control change or program change message is being sent on. To send a message on MIDI channel;

|                     |                     |                      |                      |
|---------------------|---------------------|----------------------|----------------------|
| #1 replace n with 0 | #5 replace n with 4 | #9 replace n with 8  | #13 replace n with C |
| #2 replace n with 1 | #6 replace n with 5 | #10 replace n with 9 | #14 replace n with D |
| #3 replace n with 2 | #7 replace n with 6 | #11 replace n with A | #15 replace n with E |
| #4 replace n with 3 | #8 replace n with 7 | #12 replace n with B | #16 replace n with F |



## 14.7 Preset Custom Hex/MIDI Msg. (Cont'd)

### 14.7.1 MIDI Messages For Guitar Players 101 (Cont'd)

Byte *cc* is the control change number. The MIDI specification allows 121 of them to be used freely, and different switcher manufacturers can/do use different numbers, so following is a complete list. To send control change;

|                               |                               |                               |                                |
|-------------------------------|-------------------------------|-------------------------------|--------------------------------|
| #0 replace <i>cc</i> with 00  | #31 replace <i>cc</i> with 1F | #62 replace <i>cc</i> with 3E | #93 replace <i>cc</i> with 5D  |
| #1 replace <i>cc</i> with 01  | #32 replace <i>cc</i> with 20 | #63 replace <i>cc</i> with 3F | #94 replace <i>cc</i> with 5E  |
| #2 replace <i>cc</i> with 02  | #33 replace <i>cc</i> with 21 | #64 replace <i>cc</i> with 40 | #95 replace <i>cc</i> with 5F  |
| #3 replace <i>cc</i> with 03  | #34 replace <i>cc</i> with 22 | #65 replace <i>cc</i> with 41 | #96 replace <i>cc</i> with 60  |
| #4 replace <i>cc</i> with 04  | #35 replace <i>cc</i> with 23 | #66 replace <i>cc</i> with 42 | #97 replace <i>cc</i> with 61  |
| #5 replace <i>cc</i> with 05  | #36 replace <i>cc</i> with 24 | #67 replace <i>cc</i> with 43 | #98 replace <i>cc</i> with 62  |
| #6 replace <i>cc</i> with 06  | #37 replace <i>cc</i> with 25 | #68 replace <i>cc</i> with 44 | #99 replace <i>cc</i> with 63  |
| #7 replace <i>cc</i> with 07  | #38 replace <i>cc</i> with 26 | #69 replace <i>cc</i> with 45 | #100 replace <i>cc</i> with 64 |
| #8 replace <i>cc</i> with 08  | #39 replace <i>cc</i> with 27 | #70 replace <i>cc</i> with 46 | #101 replace <i>cc</i> with 65 |
| #9 replace <i>cc</i> with 09  | #40 replace <i>cc</i> with 28 | #71 replace <i>cc</i> with 47 | #102 replace <i>cc</i> with 66 |
| #10 replace <i>cc</i> with 0A | #41 replace <i>cc</i> with 29 | #72 replace <i>cc</i> with 48 | #103 replace <i>cc</i> with 67 |
| #11 replace <i>cc</i> with 0B | #42 replace <i>cc</i> with 2A | #73 replace <i>cc</i> with 49 | #104 replace <i>cc</i> with 68 |
| #12 replace <i>cc</i> with 0C | #43 replace <i>cc</i> with 2B | #74 replace <i>cc</i> with 4A | #105 replace <i>cc</i> with 69 |
| #13 replace <i>cc</i> with 0D | #44 replace <i>cc</i> with 2C | #75 replace <i>cc</i> with 4B | #106 replace <i>cc</i> with 6A |
| #14 replace <i>cc</i> with 0E | #45 replace <i>cc</i> with 2D | #76 replace <i>cc</i> with 4C | #107 replace <i>cc</i> with 6B |
| #15 replace <i>cc</i> with 0F | #46 replace <i>cc</i> with 2E | #77 replace <i>cc</i> with 4D | #108 replace <i>cc</i> with 6C |
| #16 replace <i>cc</i> with 10 | #47 replace <i>cc</i> with 2F | #78 replace <i>cc</i> with 4E | #109 replace <i>cc</i> with 6D |
| #17 replace <i>cc</i> with 11 | #48 replace <i>cc</i> with 30 | #79 replace <i>cc</i> with 4F | #110 replace <i>cc</i> with 6E |
| #18 replace <i>cc</i> with 12 | #49 replace <i>cc</i> with 31 | #80 replace <i>cc</i> with 50 | #111 replace <i>cc</i> with 6F |
| #19 replace <i>cc</i> with 13 | #50 replace <i>cc</i> with 32 | #81 replace <i>cc</i> with 51 | #112 replace <i>cc</i> with 70 |
| #20 replace <i>cc</i> with 14 | #51 replace <i>cc</i> with 33 | #82 replace <i>cc</i> with 52 | #113 replace <i>cc</i> with 71 |
| #21 replace <i>cc</i> with 15 | #52 replace <i>cc</i> with 34 | #83 replace <i>cc</i> with 53 | #114 replace <i>cc</i> with 72 |
| #22 replace <i>cc</i> with 16 | #53 replace <i>cc</i> with 35 | #84 replace <i>cc</i> with 54 | #115 replace <i>cc</i> with 73 |
| #23 replace <i>cc</i> with 17 | #54 replace <i>cc</i> with 36 | #85 replace <i>cc</i> with 55 | #116 replace <i>cc</i> with 74 |
| #24 replace <i>cc</i> with 18 | #55 replace <i>cc</i> with 37 | #86 replace <i>cc</i> with 56 | #117 replace <i>cc</i> with 75 |
| #25 replace <i>cc</i> with 19 | #56 replace <i>cc</i> with 38 | #87 replace <i>cc</i> with 57 | #118 replace <i>cc</i> with 76 |
| #26 replace <i>cc</i> with 1A | #57 replace <i>cc</i> with 39 | #88 replace <i>cc</i> with 58 | #119 replace <i>cc</i> with 77 |
| #27 replace <i>cc</i> with 1B | #58 replace <i>cc</i> with 3A | #89 replace <i>cc</i> with 59 | #120 replace <i>cc</i> with 78 |
| #28 replace <i>cc</i> with 1C | #59 replace <i>cc</i> with 3B | #90 replace <i>cc</i> with 5A |                                |
| #29 replace <i>cc</i> with 1D | #60 replace <i>cc</i> with 3C | #91 replace <i>cc</i> with 5B |                                |
| #30 replace <i>cc</i> with 1E | #61 replace <i>cc</i> with 3D | #92 replace <i>cc</i> with 5C |                                |

Byte *vv* is the control change value and guitarists typically only use two, even though many exist. One value turns an audio loop or switching function ON and the other turns the audio loop or switching function OFF.

To turn an audio loop or switching function ON replace *vv* with 7F.

To turn an audio loop or switching function OFF replace *vv* with 00.

## 14.7 Preset Custom Hex/MIDI Msg. (Cont'd)

### 14.7.1 MIDI Messages For Guitar Players 101 (Cont'd)

Byte pp is the program change number. The MIDI specification allows 128 of them, so to send program change;

|                        |                        |                        |                         |
|------------------------|------------------------|------------------------|-------------------------|
| #0 replace pp with 00  | #32 replace pp with 20 | #64 replace pp with 40 | #96 replace pp with 60  |
| #1 replace pp with 01  | #33 replace pp with 21 | #65 replace pp with 41 | #97 replace pp with 61  |
| #2 replace pp with 02  | #34 replace pp with 22 | #66 replace pp with 42 | #98 replace pp with 62  |
| #3 replace pp with 03  | #35 replace pp with 23 | #67 replace pp with 43 | #99 replace pp with 63  |
| #4 replace pp with 04  | #36 replace pp with 24 | #68 replace pp with 44 | #100 replace pp with 64 |
| #5 replace pp with 05  | #37 replace pp with 25 | #69 replace pp with 45 | #101 replace pp with 65 |
| #6 replace pp with 06  | #38 replace pp with 26 | #70 replace pp with 46 | #102 replace pp with 66 |
| #7 replace pp with 07  | #39 replace pp with 27 | #71 replace pp with 47 | #103 replace pp with 67 |
| #8 replace pp with 08  | #40 replace pp with 28 | #72 replace pp with 48 | #104 replace pp with 68 |
| #9 replace pp with 09  | #41 replace pp with 29 | #73 replace pp with 49 | #105 replace pp with 69 |
| #10 replace pp with 0A | #42 replace pp with 2A | #74 replace pp with 4A | #106 replace pp with 6A |
| #11 replace pp with 0B | #43 replace pp with 2B | #75 replace pp with 4B | #107 replace pp with 6B |
| #12 replace pp with 0C | #44 replace pp with 2C | #76 replace pp with 4C | #108 replace pp with 6C |
| #13 replace pp with 0D | #45 replace pp with 2D | #77 replace pp with 4D | #109 replace pp with 6D |
| #14 replace pp with 0E | #46 replace pp with 2E | #78 replace pp with 4E | #110 replace pp with 6E |
| #15 replace pp with 0F | #47 replace pp with 2F | #79 replace pp with 4F | #111 replace pp with 6F |
| #16 replace pp with 10 | #48 replace pp with 30 | #80 replace pp with 50 | #112 replace pp with 70 |
| #17 replace pp with 11 | #49 replace pp with 31 | #81 replace pp with 51 | #113 replace pp with 71 |
| #18 replace pp with 12 | #50 replace pp with 32 | #82 replace pp with 52 | #114 replace pp with 72 |
| #19 replace pp with 13 | #51 replace pp with 33 | #83 replace pp with 53 | #115 replace pp with 73 |
| #20 replace pp with 14 | #52 replace pp with 34 | #84 replace pp with 54 | #116 replace pp with 74 |
| #21 replace pp with 15 | #53 replace pp with 35 | #85 replace pp with 55 | #117 replace pp with 75 |
| #22 replace pp with 16 | #54 replace pp with 36 | #86 replace pp with 56 | #118 replace pp with 76 |
| #23 replace pp with 17 | #55 replace pp with 37 | #87 replace pp with 57 | #119 replace pp with 77 |
| #24 replace pp with 18 | #56 replace pp with 38 | #88 replace pp with 58 | #120 replace pp with 78 |
| #25 replace pp with 19 | #57 replace pp with 39 | #89 replace pp with 59 | #121 replace pp with 79 |
| #26 replace pp with 1A | #58 replace pp with 3A | #90 replace pp with 5A | #122 replace pp with 7A |
| #27 replace pp with 1B | #59 replace pp with 3B | #91 replace pp with 5B | #123 replace pp with 7B |
| #28 replace pp with 1C | #60 replace pp with 3C | #92 replace pp with 5C | #124 replace pp with 7C |
| #29 replace pp with 1D | #61 replace pp with 3D | #93 replace pp with 5D | #125 replace pp with 7D |
| #30 replace pp with 1E | #62 replace pp with 3E | #94 replace pp with 5E | #126 replace pp with 7E |
| #31 replace pp with 1F | #63 replace pp with 3F | #95 replace pp with 5F | #127 replace pp with 7F |

# 15. SongSet Menu

The SongSet Menu allows for the FX1's regular presets to be organized in a custom bank to create a song and multiple songs can then be arranged into a collection of custom banks (each bank represents a song) to create a setlist.

## 15.1 Song Create/Edit

This sub-menu allows creating/editing songs. A song is a custom bank of the FX1's regular presets organized so that all the presets necessary during the performance of a song are available in one bank, eliminating the need to change banks in the middle of the song. Each song contains 6 presets, plus the Global Preset (if made available – see Section 16.6 : Global Preset Availability). The FX1 can support 99 songs, each with a unique 13 character name, and they can be accessed via the SONG and SET0 – SET9 Operating Modes.

From the Edit Menu, press the **SONGSET** switch one time, the display will show.

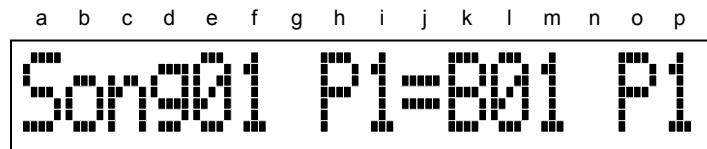

- e and f on the display indicate the song number (01 to 99) that is going to be edited/created.
- i on the display indicates the preset number (1 to 6 or 0 for the Global Preset) within the song.
- l and m on the display indicate the bank number (01 to 21) that the original preset is located in.
- p refers to the original preset (1 to 6 or 0 for the Global Preset) in the above bank to be used in the song.

The LED above the following switches will turn ON indicating the switches can be used while in this sub-menu.

- SELECT** Press to move the cursor from left to right (and back) between the song, bank and presets.
- EXIT/SAVE** Press to return to the Edit Menu, any changes made while in this sub-menu will automatically be saved.
- SONGSET** Press to advance to the next SongSet sub-menu, any changes made while in this sub-menu will automatically be saved. The LED above this switch will always flash as a reminder that a SongSet sub-menu is selected.
- NAMES** Press/hold to display the user assigned name for the song or the original preset and release to return to the above display format. When the cursor is at display locations e, f, or i, pressing/holding this switch will display the name assigned to the song that is being edited/created. When the cursor is at display locations l, m or p, pressing/holding this switch will display the name assigned to the original preset that is going to be used in the song.
- 0 – 9** Press two switches to enter a song number between 01 & 99, press two switches to enter a bank number between 01 & 21 and press one switch to enter a preset number between 1 & 6 or 0 (for the Global Preset). When the cursor is at one of the preset locations (i or p) the LED above switches **7**, **8** and **9** will turn OFF since there are no such presets.

## 15.2 Setlist Create/Edit

This sub-menu allows creating/editing setlists. A setlist is a collection of 50 custom banks and each bank represents a song. Setlists allow songs to be organized in the order they will be performed so that during a live performance only one bank switch has to be pressed (once) in between songs. The FX1 can support 10 setlists, each with a unique 13 character name, and they are accessed via the SET0 – SET9 Operating Modes.

From the Edit Menu, press the **SONGSET** switch two times, the display will show.

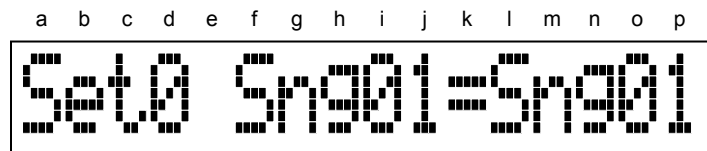

- d indicates the setlist number (0 to 9) that is going to be edited/created.
- i and j on the display indicate the song number (01 to 50) within the setlist.
- o and p indicate the original song number (01 to 99) to be used in the setlist.

The LED above the following switches will turn ON indicating the switches can be used while in this sub-menu.

- SELECT** Press to move the cursor from left to right (and back) between the setlist and songs.
- EXIT/SAVE** Press to return to the Edit Menu, any changes made while in this sub-menu will automatically be saved.
- SONGSET** Press to return to the first SongSet sub-menu, any changes made while in this sub-menu will automatically be saved. The LED above this switch will always flash as a reminder that a SongSet sub-menu is selected.
- NAMES** Press/hold to display the user assigned name for the setlist or the original song and release to return to the above display format. When the cursor is at display locations d, i, or j, pressing/holding this switch will display the name assigned to the setlist that is being edited/created. When the cursor is at display locations o or p, pressing/holding this switch will display the name assigned to the original song that is going to be used in the setlist.
- 0 – 9** Press one switch to enter a setlist number between 0 & 9, press two switches to enter a song number between 01 & 50 (for a song within the setlist) and press two switches to enter a song number between 01 & 99 (for the original song to be used in the setlist).

# 16. Utility Menu

The Utility Menu allows configuring the FX1's general functionality by selecting its operating mode and defining how the preset switches, instant access switches and expression ports will function when used. Its sub-menu's also provide access to the user data/dump, delete/restore, expression pedal port calibration and firmware version/update utilities.

## 16.1 Operating Mode

This sub-menu allows selecting the FX1's operating mode.

From the Edit Menu, press the **UTILITY** switch one time, the display will show.

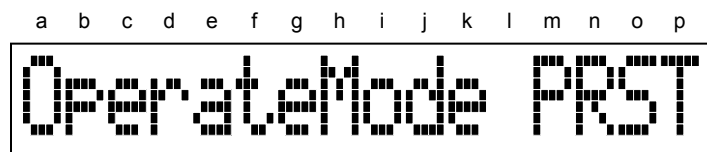

- m to p on the display indicate the operating mode (PRST, SET0 – SET9, SLAV or SONG).

The LED above the following switches will turn ON indicating the switches can be used while in this sub-menu.

**INC & DEC** Press/hold to move/scroll through and select the desired operating mode.

**EXIT/SAVE** Press to return to the Edit Menu, any changes made while in this sub-menu will automatically be saved.

**UTILITY** Press to advance to the next Utility sub-menu, any changes made while in this sub-menu will automatically be saved. The LED above this switch will always flash as a reminder that a Utility sub-menu is selected.

**NAMES** Press/hold to display the user assigned name for a setlist (when SET0 – SET9 Operating Mode is shown/selected) and release to return.

## 16.2 S1 – S12 Switch Link

This sub-menu allows linking up to two sets of instant access switches. Each linked set may contain up to four instant access switches. When instant access switches are linked together in a set, only one of the instant access switches can be ON at any time in each set, so pressing an instant access switch that is OFF, will turn it ON and the switch that was ON before will be turned OFF automatically.

The ability to link instant access switches is particularly handy for users of multi-channel guitar amplifiers. Selecting channels on an amplifier using the instant access switches on any other MIDI footcontroller (because Axess is the 1<sup>st</sup> and currently the only company offering this feature) can be very confusing. For example, some four channel guitar amps require two instant access switches be used in order to select a channel;

Switch 1 LED off & Switch 2 LED off = Channel 1  
Switch 1 LED off & Switch 2 LED on = Channel 2  
Switch 1 LED on & Switch 2 LED off = Channel 3  
Switch 1 LED on & Switch 2 LED on = Channel 4

Selecting channel 4 when channel 1 is ON (or vice-versa) will require two instant access switch presses, not to mention the time required to think about what combination will select what channel because of the four different LED combinations. Linking instant access switches on the FX1 will result in one instant access switch (and it's LED) being assigned to each amplifier channel. So selecting a channel is only one instant access switch press away and figuring out what channel is ON is clearly displayed by a single LED at all times.

From the Edit Menu, press the **UTILITY** switch two times, the display will show.

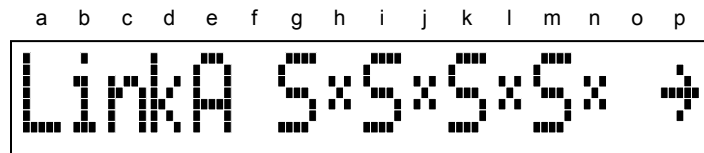

- e on the display indicates the set (A or B) of linked instant access switches.
- h, j, l and n on the display indicate the four switches that are linked together.

The LED above the following switches will turn ON indicating the switches can be used while in this sub-menu.

- ENTER →** Press to switch/toggle between the two sets (A or B) of linked instant access switches.
- SELECT** Press to move the cursor from left to right (and back) through display locations h, j, l and n.
- EXIT/SAVE** Press to return to the Edit Menu, any changes made while in this sub-menu will automatically be saved.
- INC & DEC** Press/hold to move/scroll through and select the instant access switch (1 to 12 or x = no switch) to be linked.
- UTILITY** Press to advance to the next Utility sub-menu, any changes made while in this sub-menu will automatically be saved. The LED above this switch will always flash as a reminder that a Utility sub-menu is selected.
- NAMES** Press/hold to display the user assigned name for the instant access switch at the current cursor position and release to return to the above display format. If there is no instant access switch linked at the current cursor position, the LED above this switch will turn OFF.

## **16.2 S1 – S12 Switch Link (Cont'd)**

*An instant access switch can only be linked once.*

*Pressing a linked instant access switch that is already ON will do nothing (no MIDI messages will be transmitted).*

*When selecting a preset, only the ON state MIDI messages of the switch that is ON (for LinkA and LinkB) will be transmitted as part of the preset. The OFF state MIDI messages for the other instant access switches (that are OFF) will not be transmitted as part of the preset.*

*If the FX1 has already been setup with presets that have multiple instant access switches turned ON, and they have now been linked together, the instant access switch considered ON when selecting a preset will be the one with the lowest switch value (i.e. **S1** is lower than **S2** to **S12** and **S3** is lower than **S4** to **S12**...).*

*Pressing a linked instant access switch that is OFF, will turn it ON and cause the FX1 to transmit its ON state MIDI messages and turn OFF the other linked instant access switch without transmitting its OFF state MIDI messages. There are several reasons why the FX1 has been designed to work this way, but mainly it has to do with how most commercial guitar switchers operate and/or respond to MIDI messages... That's (another reason) why Axess designed instant access switches **S1** to **S12** with the ability to transmit custom hex / MIDI messages (along with their control change and program change messages) so that when a linked switch is turned ON it can transmit additional messages to control the guitar switcher appropriately. Axess Electronics' AC8 Amplifier Controller has been designed to function and respond appropriately to the FX1's linked instant access switches but users of other commercial guitar switchers will more than likely need to make use of the S1 – S12 Custom Hex / MIDI Messages.*

## 16.3 Instant Access Switch Type

This sub-menu allows the twenty-four instant access switches to be individually configured to function as latching (default) or hold type switches (these settings are global – not per preset).

From the Edit Menu, press the **UTILITY** switch three times, the display will show.

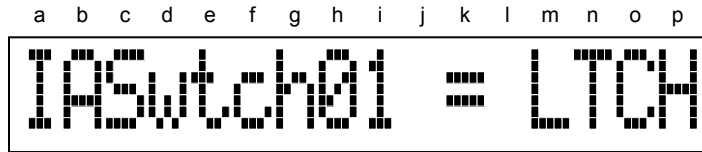

- h and i on the display indicate the instant access switch (01 to 24).
- m to p indicate the instant access switch type/setting (LTCH or HOLD).

The LED above the following switches will turn ON indicating the switches can be used while in this sub-menu.

- INC & DEC** Press/hold to move/scroll through the 24 instant access switches.
- EXIT/SAVE** Press to return to the Edit Menu, any changes made while in this sub-menu will automatically be saved.
- UTILITY** Press to advance to the next Utility sub-menu, any changes made while in this sub-menu will automatically be saved. The LED above this switch will always flash as a reminder that a Utility sub-menu is selected.
- SELECT** Press to switch/toggle how the instant access switch will function, either as a latching (LTCH) or hold (HOLD) type switch.
- NAMES** Press/hold to display the user assigned name for the instant access switch and release to return to the above display format.

*Latch (LTCH) type switches transmit their ON state MIDI messages when the switch is pressed/released and its LED is turned ON. Pressing/releasing the switch again transmits its OFF state MIDI messages and turns its LED OFF. When changing presets, the ON or OFF status of a LTCH type switch is stored as part of the preset and so the ON state or OFF state MIDI messages are always transmitted when a preset is selected.*

*Hold (HOLD) type switches transmit their ON state MIDI messages when the switch is pressed and its LED is turned ON. Releasing the switch transmits its OFF state MIDI messages and turns its LED OFF. When changing presets, switches setup as HOLD type switches do not send any MIDI messages as part of the preset.*



## 16.4 XP1 – XP4 Port Type

This sub-menu allows the four expression pedal ports to be individually configured to accept a pedal (linear or audio/logarithmic taper) or a switch, ensuring the FX1 will react properly and consistently when either is connected.

From the Edit Menu, press the **UTILITY** switch four times, the display will show.

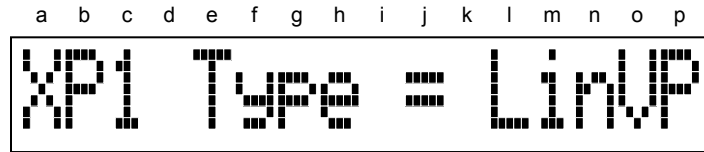

- c on the display indicates the expression pedal port (1 to 4).
- l to p indicate what is (or is going to be) connected to the expression pedal port (LinVP, LogVP or SWTCH).

The LED above the following switches will turn ON indicating the switches can be used while in this sub-menu.

**INC & DEC** Press/hold to move/scroll through the 4 expression pedal ports.

**EXIT/SAVE** Press to return to the Edit Menu, any changes made while in this sub-menu will automatically be saved.

**UTILITY** Press to advance to the next Utility sub-menu, any changes made while in this sub-menu will automatically be saved. The LED above this switch will always flash as a reminder that a Utility sub-menu is selected.

**SELECT** Press to switch/toggle between what is (or is going to be) connected to the expression pedal port shown, either a linear tapered volume pedal (LinVP), an audio/logarithmic tapered volume pedal (LogVP) or a switch (SWTCH).

*Please note that selecting the LinVP option will cause the FX1 to track the pedal taper directly. So if a linear tapered volume pedal is connected, the transmitted MIDI data will be linear and if an audio/logarithmic tapered volume pedal is connected the transmitted MIDI data will be logarithmic. When the LogVP option is selected, the FX1 will try to convert the connected pedal (i.e. an audio/logarithmic tapered volume pedal) so that it acts like a linear tapered volume pedal.*

## 16.5 XP1 – XP4 Port Calibration

This sub-menu allows the four expression pedal ports to be individually calibrated ensuring the FX1 will react properly and consistently whenever the pedals/switches connected to the ports are moved/pressed. Calibration consists of determining the minimum and maximum resistance points of the pedals/switches connected to the expression pedal ports and assigning a MINimum MIDI control value of 000 and a MAXimum MIDI control value of 127, respectively or vice-versa...

*Typically when using expression pedals, heel down is the minimum position and heel up is the maximum position. To reverse this when using the FX1, simply calibrate the desired expression pedal port(s) with heel up for MINimum and heel down for MAXimum.*

From the Edit Menu, press the **UTILITY** switch five times, the display will show.

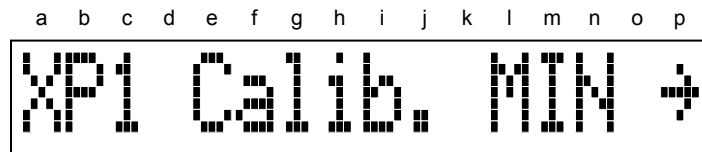

- c on the display indicates the expression pedal port (1 to 4) being calibrated.
- l to n indicate which position/MIDI control value (MIN/000 or MAX/127) is being calibrated.

The LED above the following switches will turn ON indicating the switches can be used while in this sub-menu.

**EXIT/SAVE** Press to return to the Edit Menu.

**INC & DEC** Press/hold to move/scroll through the 4 expression pedal ports.

**ENTER →** Press to switch between calibrating the MINimum (000) and MAXimum (127) MIDI control values.

**UTILITY** Press to advance to the next Utility sub-menu. The LED above this switch will always flash as a reminder that a Utility sub-menu is selected.

**SELECT** Press to assign a MIDI control value of 000 to the current pedal/switch position when “MIN” is displayed and press to assign a MIDI control value of 127 to the current pedal/switch position when “MAX” is displayed. The LED above this switch will only turn ON after the pedal/switch connected to the displayed expression pedal port has been moved/pressed.

### 16.5.1 Calibrating An Expression Pedal Port

1. Refer to Section 16.4 : XP1 – XP4 Port Type in this User Manual and configure each expression pedal port to accept a pedal or a switch, depending on what is (or will be) physically connected to the four ¼” expression pedal port jacks.
2. Return back to this Utility sub-menu, the display will show.

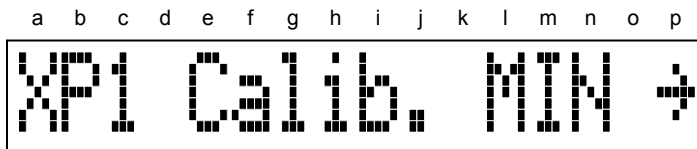

3. Press the **INC** or **DEC** switch to select the expression pedal port to be calibrated.

## 16.5 XP1 – XP4 Port Calibration (Cont'd)

- If calibrating a pedal, move it to its minimum position, which is typically heel down and if calibrating a switch, press (and release if necessary and/or press again...) until its minimum position has been reached. As soon as the pedal/switch is moved/pressed, the **SELECT** switch LED will turn ON and the display will show.

a b c d e f g h i j k l m n o p

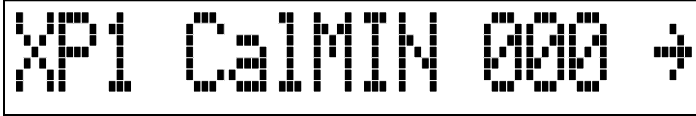

The display shows 'XP1 CalMIN 000' with a right arrow cursor at position p. The characters are in a pixelated font. The '000' is at positions l, m, and n.

The number shown at display locations l to n is an uncalibrated value and it will change as the pedal/switch is moved/pressed. It may not reach 000 due to pedal/switch tolerances, but move/press the pedal/switch until the displayed number is as low as possible.

- Press the **SELECT** switch to assign a MIDI control value of 000 to the current pedal/switch position. The **SELECT** switch LED will turn OFF and the display will show.

b c d e f g h i j k l m n o p

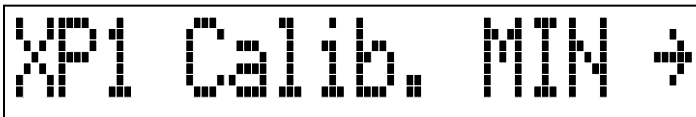

The display shows 'XP1 Calib. MIN' with a right arrow cursor at position p. The characters are in a pixelated font. 'MIN' is at positions j, k, and l.

- Press the **ENTER** → switch and the display will show.

a b c d e f g h i j k l m n o p



The display shows 'XP1 Calib. MAX' with a right arrow cursor at position p. The characters are in a pixelated font. 'MAX' is at positions j, k, and l.

- If calibrating a pedal, move it to its maximum position, which is typically heel up and if calibrating a switch, press (and release if necessary and/or press again...) until its maximum position has been reached. As soon as the pedal/switch is moved/pressed, the **SELECT** switch LED will turn ON and the display will show.

a b c d e f g h i j k l m n o p



The display shows 'XP1 CalMAX 127' with a right arrow cursor at position p. The characters are in a pixelated font. '127' is at positions l, m, and n.

The number shown at display locations l to n is an uncalibrated value and it will change as the pedal/switch is moved/pressed. It may not reach 127 due to pedal/switch tolerances, but move/press the pedal/switch until the displayed number is as high as possible.

- Press the **SELECT** switch to assign a MIDI control value of 127 to the current pedal/switch position. The **SELECT** switch LED will turn OFF and the display will show.

a b c d e f g h i j k l m n o p

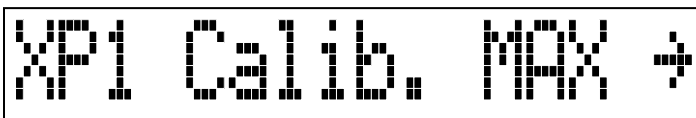

The display shows 'XP1 Calib. MAX' with a right arrow cursor at position p. The characters are in a pixelated font. 'MAX' is at positions j, k, and l.

- Repeat steps 3 to 8 to calibrate the other ports or press the **EXIT/SAVE** or **UTILITY** switch to go elsewhere.

## 16.6 Global Preset Availability

This sub-menu allows the Global Preset to be enabled or disabled when in the PRST and SONG/SET Operating Modes. If enabled, pressing the active preset switch will select the Global Preset and will cause the FX1 to transmit the MIDI data associated with the Global Preset. If the Global Preset is disabled, pressing the active preset switch will cause the FX1 to re-transmit the MIDI data associated with the active preset.

From the Edit Menu, press the **UTILITY** switch six times, the display will show.

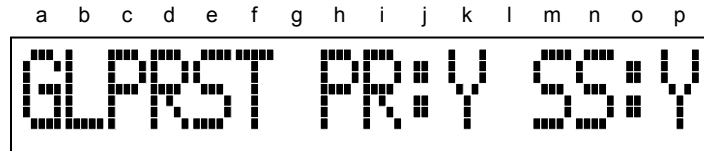

- k on the display indicates whether the Global Preset is available in the PRST Operating Mode.
- p on the display indicates whether the Global Preset is available in the SONG/SET Operating Modes.

The LED above the following switches will turn ON indicating the switches can be used while in this sub-menu.

- NO** Press to disable (N will be displayed) the Global Preset.
- YES** Press to enable (Y will be displayed) the Global Preset.
- SELECT** Press to move the cursor between the PRST and SONG/SET Operating Modes.
- EXIT/SAVE** Press to return to the Edit Menu, any changes made while in this sub-menu will automatically be saved.
- UTILITY** Press to advance to the next Utility sub-menu, any changes made while in this sub-menu will automatically be saved. The LED above this switch will always flash as a reminder that a Utility sub-menu is selected.

*Disabling the Global Preset does NOT delete any MIDI data, it simply disables the Global Preset from being selected while in the applicable operating mode(s).*

## 16.7 Data Dump/Load

This sub-menu allows the FX1 user data to be DUMPed (transmitted) or LOAded (received) to/from a computer, another FX1 or a MIDI data storage device, via the FX1's MIDI OUT (not the TO RACK jack) and MIDI IN jacks. User data is DUMPed and LOAded as a MIDI sysex (system exclusive) message.

From the Edit Menu, press the **UTILITY** switch seven times, the display will show.



- l to o on the display indicate whether user data is going to be DUMPed or LOAded.

The LED above the following switches will turn ON indicating the switches can be used while in this sub-menu.

**SELECT** Press to select DUMP or LOAD.

**ENTER →** Press to start DUMPing or LOAding data.

**EXIT/SAVE** Press to return to the Edit Menu (nothing will be DUMPed or LOAded).

**UTILITY** Press to advance to the next Utility sub-menu (nothing will be DUMPed or LOAded). The LED above this switch will always flash as a reminder that a Utility sub-menu is selected.

*When the FX1 is DUMPing user data, "DUMP!" will flash and when it's finished "DUMP!" will stop flashing and change to "DONE!".*

*When the FX1 is LOAding user data, "LOAD!" will flash and when it's finished "LOAD!" will stop flashing and change to "DONE!".*

*If the FX1 error checking software detects that the user data sysex message being LOAded is corrupt, "LOAD!" will stop flashing and change to "REDO!".*

*If the FX1 does not receive a valid user data sysex message within 10 seconds of "LOAD!" starting to flash, "LOAD!" will stop flashing and change to "REDO!".*

*When the display shows "REDO!" or "DONE!", pressing the **NEXT** switch will do nothing. The **SELECT** switch must first be pressed to select "DUMP!" or "LOAD!".*

### 16.7.1 Remote Data Dump/Load

The following MIDI sysex messages are utilized by the FX1 (only when it is in the Data Dump/Load sub-menu) and the FX1 Editor (for the Mac/PC) to initiate a data dump/load on the FX1 from a remote location...

- |                      |  |
|----------------------|--|
| F0 00 01 4B 01 10 F7 | When received by the FX1 via its MIDI IN jack, it will respond by DUMPing (sending) its user data via the MIDI OUT jack.   |
| F0 00 01 4B 01 11 F7 | When received by the FX1 via its MIDI IN jack, it will expect to start LOAding (receiving) user data via the MIDI IN jack within 10 seconds. If the FX1 does not receive valid user data within 10 seconds of "LOAD!" starting to flash, "LOAD!" will stop flashing and change to "REDO!". |
| F0 00 01 4B 01 12 F7 | Transmitted by the FX1 via its MIDI OUT jack after it has successfully LOAded (received) user data via its MIDI IN jack.   |
| F0 00 01 4B 01 13 F7 | Transmitted by the FX1 via its MIDI OUT jack after it has NOT successfully LOAded (received) user data via its MIDI IN jack.   |

## 16.8 Delete/Restore

This sub-menu allows deleting/restoring a preset, song, setlist, instant access switch or the FX1.

From the Edit Menu, press the **UTILITY** switch eight times, the display will show.

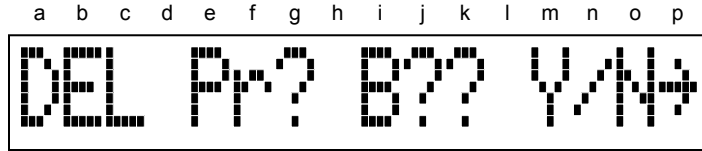

- g indicates the preset (1 to 6 or 0 for the Global Preset) that is going to be deleted/restored.
- j and k on the display indicate the bank (01 to 21) that the preset (being deleted) is located in.

Press the **ENTER** → switch and the display will show.

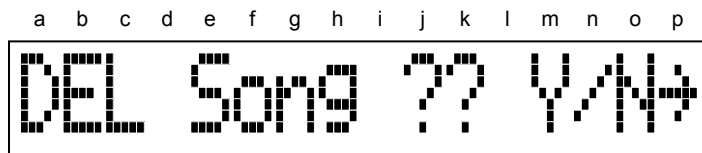

- j and k indicate the song number (01 to 99) that is going to be deleted/restored.

Press the **ENTER** → switch and the display will show.

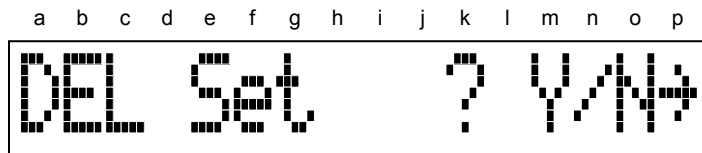

- k on the display indicates the setlist number (0 to 9) that is going to be deleted/restored.

Press the **ENTER** → switch and the display will show.

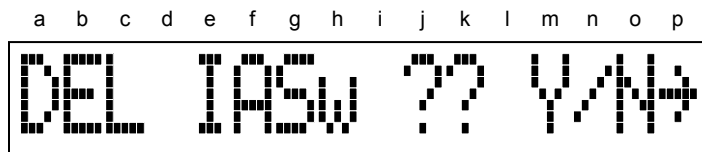

- j and k indicate the instant access switch number (01 to 24) that is going to be deleted/restored.

Press the **ENTER** → switch and the display will show.

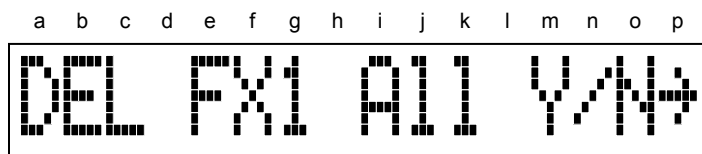

There are now three options;

1. Press the **ENTER** → switch again to return to the top (nothing will be deleted/restored).
2. Press the **NO** switch to abort the delete/restore process and automatically return to the top.
3. Press the **YES** switch to begin the delete/restore process (a backup is the only way to go back).

## 16.8 Delete/Restore (Cont'd)

The LED above the following switches will turn ON indicating the switches can be used while in this sub-menu.

**EXIT/SAVE** Press to return to the Edit Menu (nothing will be deleted/restored).

**ENTER →** Press to move through the five parameters that can be deleted/restored.

**0 - 9** Press one switch to enter a preset number between 1 & 6 or 0 (for the Global Preset), press two switches to enter a bank number between 01 & 21, press two switches to enter a song number between 01 & 99, press one switch to enter a setlist number between 0 & 9 and press two switches to enter an instant access switch number between 01 & 24. The LED above these switches will only turn ON when the switches can be used.

**UTILITY** Press to advance to the next Utility sub-menu (nothing will be deleted). The LED above this switch will always flash as a reminder that a Utility sub-menu is selected.

**SELECT** Press to move the cursor between the preset number and the bank number. The LED above this switch will only turn ON when the preset number and bank number are displayed.

**NAMES** Press/hold to display the user assigned name for a preset, a song, a setlist or an instant access switch and release to return. The LED above this switch will only turn ON after a valid number has been entered for a preset (and the bank it's in), a song, a setlist or an instant access switch.

**NO & YES** The LED above these switches will turn ON after a valid number has been entered for a preset (and the bank it's in), a song, a setlist or an instant access switch. Press the **NO** switch to abort the delete/restore process, any numbers entered will return to question marks. Press the **YES** switch to begin the delete/restore process. While the FX1 is deleting/restoring a parameter, the display will show.

a b c d e f g h i j k l m n o p



Deleting... ? ? ?

## 16.9 Firmware Version & Update

This sub-menu displays the current version of the FX1 firmware/software and it must be selected in order for the FX1 to receive a firmware update via its MIDI IN jack.

Visit the FX1 page on our website to see what the current firmware version is and how to get an update (if available).

From the Edit Menu, press the **UTILITY** switch nine times, the display will show (the actual version number may differ depending on when this manual was released/published).

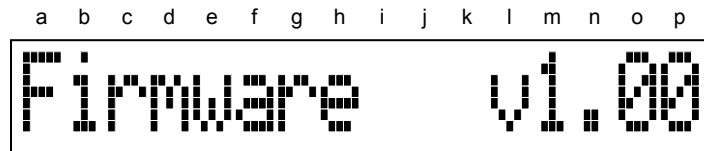

- m to p on the display indicate the firmware version number.

The LED above the following switches will turn ON indicating the switches can be used while in this sub-menu.

**EXIT/SAVE** Press to return to the Edit Menu.

**UTILITY** Press to return to the first Utility sub-menu. The LED above this switch will always flash as a reminder that a Utility sub-menu is selected.

### 16.9.1 Updating The FX1 Firmware

To update the FX1 firmware, a Mac/PC with a MIDI interface (Axess uses and recommends the external USB/MIDI interfaces made by [www.m-audio.com](http://www.m-audio.com) ) and a software utility capable of sending MIDI sysex messages will be necessary. Always make a backup of the FX1 user data prior to updating its firmware, just in case, so the same software utility should also be able to receive MIDI sysex messages. Obviously the FX1 Editor (for the Mac/PC) is more than capable of updating the FX1 firmware, but other software utilities can also be used such as; SysEx Librarian from [www.snoize.com](http://www.snoize.com) for the Mac and MIDI-OX from [www.midiox.com](http://www.midiox.com) for the PC.

After installing MIDI-OX, configure the Low Level Input/Output Buffers as follows – Size (2048), Num (128) and Delay Between Buffers (0 msec).

1. Refer to Section 16.7 : Data Dump/Load in this User Manual and perform a Data Dump of the FX1 user data and be sure to save the file !!!
2. Return back to this Utility sub-menu, the display will show (the actual version number may differ depending on when this manual was released/published).

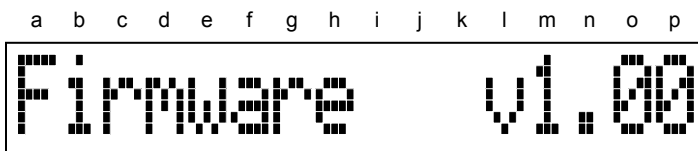

3. Connect a MIDI cable between the MIDI OUT jack of the Mac/PC MIDI interface and the FX1 MIDI IN jack.
4. Using the Mac/PC software utility, send/transmit the new firmware sysex file to the FX1, the display will show.

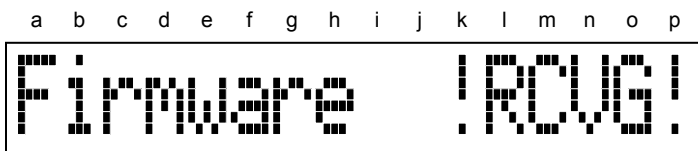



## 16.9 Firmware Version & Update (Cont'd)

### 16.9.1 Updating The FX1 Firmware (Cont'd)

5. “!RCVG!” will start to flash indicating that the FX1 is receiving the new firmware sysex file. File reception will take approximately 1 minute, so please be patient and let it finish. FYI – the **EXIT/SAVE** switch LED should be ON and the **UTILITY** switch LED should still be flashing.
6. If the firmware sysex file reception is not successful, the display will show.

a b c d e f g h i j k l m n o p

A rectangular LCD display showing the text "Firmware Reload!" in a pixelated font. The letters are white on a black background. Above the display, the letters 'a' through 'p' are spaced out to indicate the character positions.

7. “Reload!” indicates that the firmware sysex file was not received properly, and to try again...
8. Upon successful reception and error checking of the new firmware sysex file, the display will show.

a b c d e f g h i j k l m n o p

A rectangular LCD display showing the text "Firmware !BURN!" in a pixelated font. The letters are white on a black background. Above the display, the letters 'a' through 'p' are spaced out to indicate the character positions.

9. The **EXIT/SAVE** and **UTILITY** switch LED's will turn OFF and approximately 10 seconds later “!BURN!” will start to flash, indicating that the FX1 is being updated with the new firmware. Self-programming/burning of the FX1 microcontroller will take approximately 1 minute, so please be patient (and let it finish).
10. After the microcontroller has self-programmed, the FX1 will automatically reboot itself with the new firmware.

*The FX1 has been designed with some fail-safe functionality so if power is accidentally lost/removed while receiving a new firmware sysex file, the FX1 will revert back to the current version. If power is accidentally lost/removed while self-programming/burning the microcontroller, it'll automatically restart and/or continue the next time it's powered up.*

# 17. Cables

Using the XPDL:1 – XPDL:4 and/or S11:S12 jacks on the FX1 requires that the proper SHIELDED cable(s) be used.

## 17.1.1 XPDL & External Switch

Using an external switch such as the Boss FS-5L (latching) or FS-5U (momentary) requires the use of a standard 1/4" mono cable.

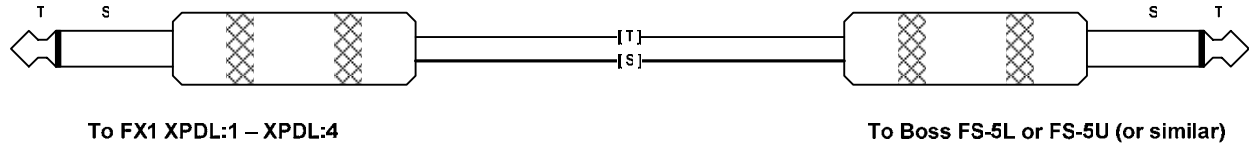

## 17.1.2 XPDL & External Volume Pedal

Using an external volume pedal such as the Ernie Ball 6166 (or the Jr. models) requires the use of a special cable (sometimes called an "insert cable") with a standard 1/4" TRS (stereo) plug on one end and two standard 1/4" mono plugs on the other end.

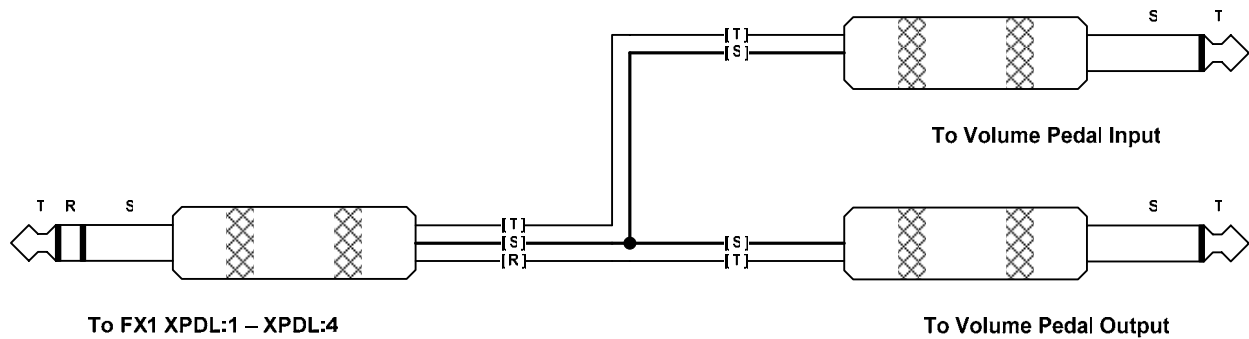

## 17.1.3 XPDL & External Expression Pedal

Using an external expression pedal such as the Boss FV-300L requires the use of a standard 1/4" TRS (stereo) cable.

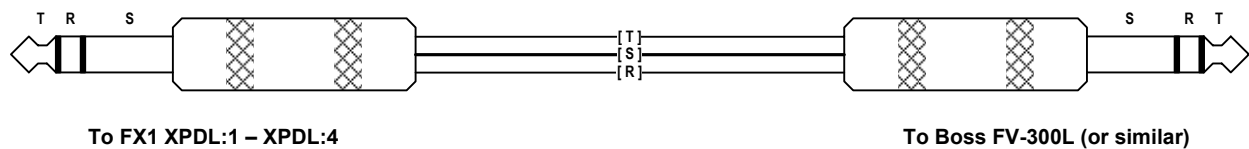

# 17. Cables (Cont'd)

## 17.1.4 S11:S12 & External Dual Footswitch

Using an external dual footswitch such as the Boss FS-6 (with both switches set for momentary operation) requires the use of a standard 1/4" TRS (stereo) cable.

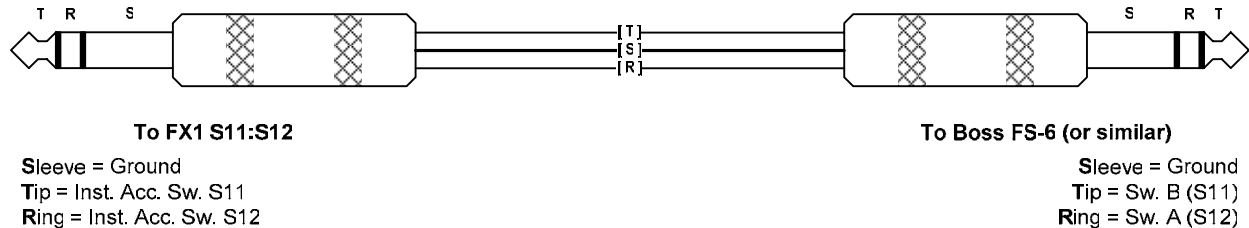

## 17.1.5 S11:S12 & Two External Footswitches

Using two separate external footswitches such as the Boss FS-5U (momentary) requires the use of a special cable (sometimes called an "insert cable") with a standard 1/4" TRS (stereo) plug on one end and two standard 1/4" mono plugs on the other end.

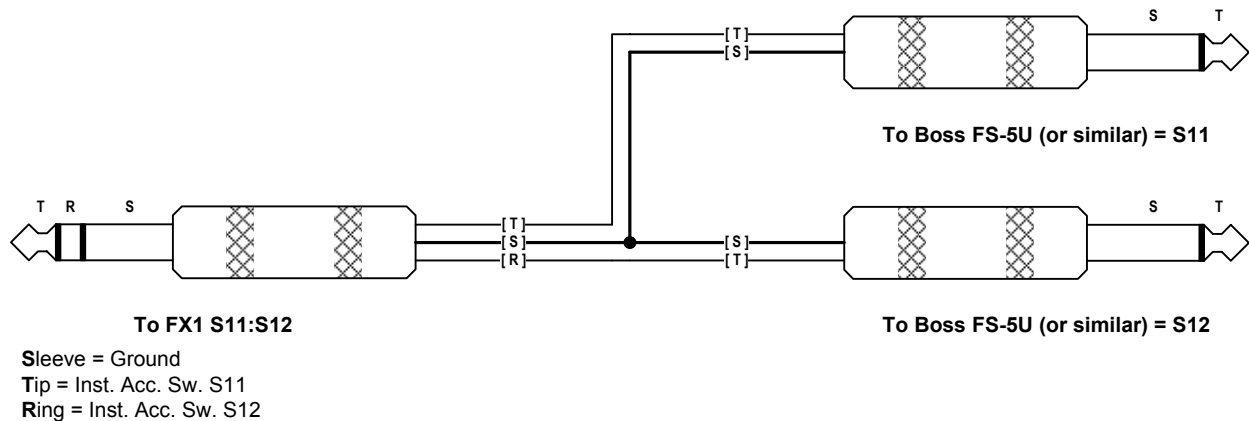

# 17. Cables (Cont'd)

## 17.1.6 S11:S12 & Single External Footswitch (S11)

Using a single external footswitch such as the Boss FS-5U (momentary) for remote access of ONLY the S11 instant access switch requires the use of a special cable with a standard 1/4" TRS (stereo) plug (with its Ring unconnected) on one end and one standard 1/4" mono plug on the other end.

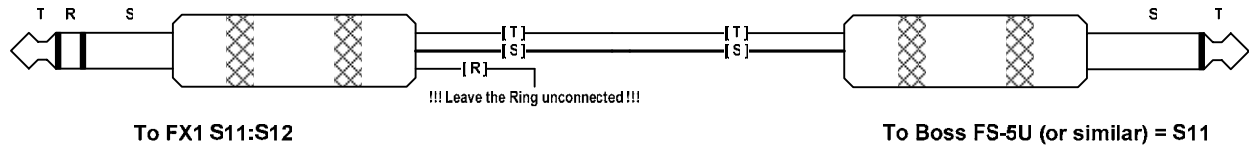

Sleeve = Ground  
Tip = Inst. Acc. Sw. S11  
Ring = Inst. Acc. Sw. S12

## 17.1.7 S11:S12 & Single External Footswitch (S12)

Using a single external footswitch such as the Boss FS-5U (momentary) for remote access of ONLY the S12 instant access switch requires the use of a special cable with a standard 1/4" TRS (stereo) plug (with its Tip unconnected) on one end and one standard 1/4" mono plug on the other end.

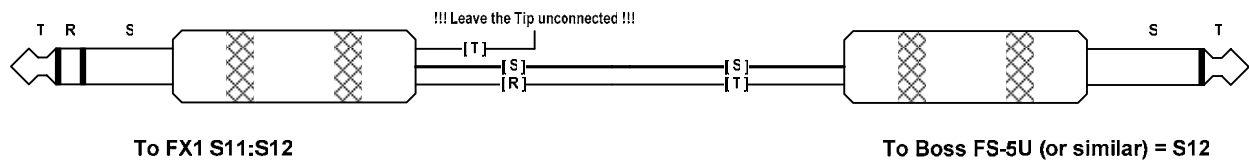

Sleeve = Ground  
Tip = Inst. Acc. Sw. S11  
Ring = Inst. Acc. Sw. S12

# 18. Remote Control

## 18.1.1 PRST Operating Mode

MIDI program change messages received (via the MIDI IN jack – see Section 8.1.7) on the MIDI channel that the FX1 is set to receive them on (see Section 12.1) will allow for remote selection of the FX1 presets by a sequencer or another MIDI footcontroller. The following table shows the relationship between the MIDI program change messages received and the FX1 banks/presets. MIDI program change number 127 selects the Global Preset.

| BANK | P1  | P2  | P3  | P4  | P5  | P6  |
|------|-----|-----|-----|-----|-----|-----|
| 01   | 1   | 2   | 3   | 4   | 5   | 6   |
| 02   | 7   | 8   | 9   | 10  | 11  | 12  |
| 03   | 13  | 14  | 15  | 16  | 17  | 18  |
| 04   | 19  | 20  | 21  | 22  | 23  | 24  |
| 05   | 25  | 26  | 27  | 28  | 29  | 30  |
| 06   | 31  | 32  | 33  | 34  | 35  | 36  |
| 07   | 37  | 38  | 39  | 40  | 41  | 42  |
| 08   | 43  | 44  | 45  | 46  | 47  | 48  |
| 09   | 49  | 50  | 51  | 52  | 53  | 54  |
| 10   | 55  | 56  | 57  | 58  | 59  | 60  |
| 11   | 61  | 62  | 63  | 64  | 65  | 66  |
| 12   | 67  | 68  | 69  | 70  | 71  | 72  |
| 13   | 73  | 74  | 75  | 76  | 77  | 78  |
| 14   | 79  | 80  | 81  | 82  | 83  | 84  |
| 15   | 85  | 86  | 87  | 88  | 89  | 90  |
| 16   | 91  | 92  | 93  | 94  | 95  | 96  |
| 17   | 97  | 98  | 99  | 100 | 101 | 102 |
| 18   | 103 | 104 | 105 | 106 | 107 | 108 |
| 19   | 109 | 110 | 111 | 112 | 113 | 114 |
| 20   | 115 | 116 | 117 | 118 | 119 | 120 |
| 21   | 121 | 122 | 123 | 124 | 125 | 126 |

## 18.1.2 SETn Operating Mode

When in one of the ten Setlist (SET0 – SET9) Operating Modes, MIDI control change and MIDI program change messages received (via the MIDI IN jack – see Section 8.1.7) on the MIDI channel that the FX1 is set to receive them on (see Section 12.1) will allow for remote selection of the FX1 songs/presets by a sequencer...

MIDI control change number 32 with a control value between 001 and 050 selects song 01 to 50 in the current setlist.

MIDI program change number 1 to 7 selects preset P1 to P6 and the Global Preset, respectively, in the current song.

## 18.1.3 SONG Operating Mode

MIDI control change and MIDI program change messages received (via the MIDI IN jack – see Section 8.1.7) on the MIDI channel that the FX1 is set to receive them on (see Section 12.1) will allow for remote selection of the FX1 songs/presets by a sequencer...

MIDI control change number 32 with a control value between 001 and 099 selects song 01 to 99.

MIDI program change number 1 to 7 selects preset P1 to P6 and the Global Preset, respectively, in the current song.

# 19. Master / Slave Loop

Two or more FX1's can be setup to operate in a Master/Slave Loop, allowing multiple FX1's to control the same guitar rig from remote onstage and offstage locations.

A Master/Slave Loop consists of a single master FX1 (set to the PRST, SONG or one of the ten SET0 – SET9 Operating Modes) and as many slaved FX1's as necessary (all set to the SLAV Operating Mode), and they will all act like the master FX1. While it is theoretically possible to connect an infinite number of FX1's in a Master/Slave Loop, the practical limit will be determined by money, cable length and power distribution.

## 19.1.1 Master/Slave Connections

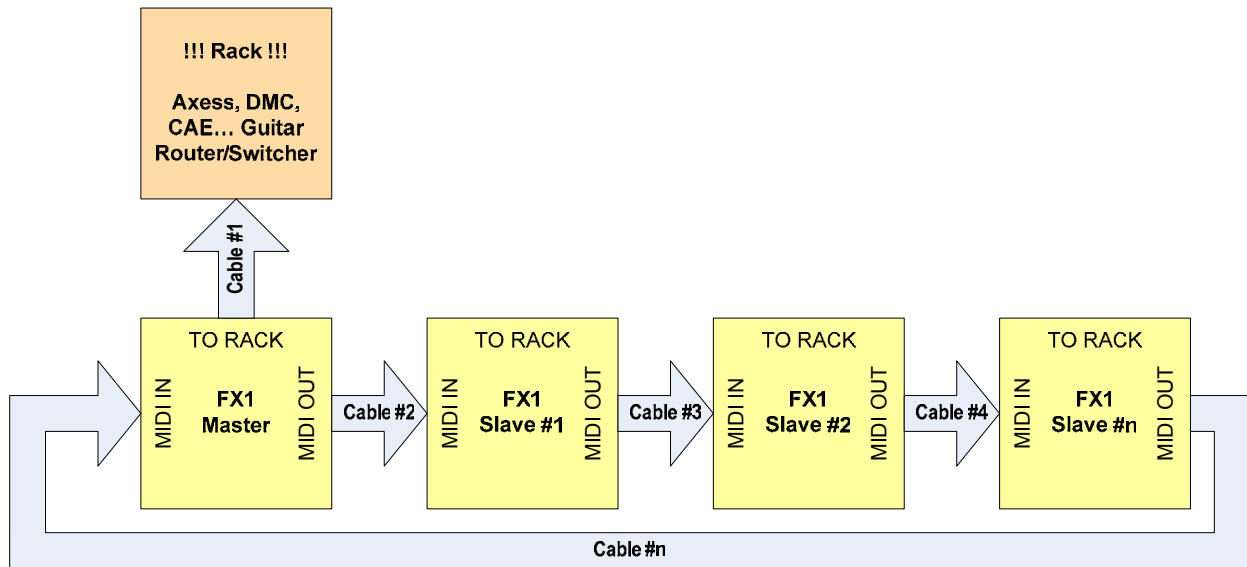

### !!! ATTENTION !!!

A guitar router/switcher should ONLY supply phantom power to a single FX1, or any other footcontroller for that matter... As such, two options exist for powering a Master/Slave Loop of FX1's.

Option #1 – The master FX1 or one of the slaved FX1's is supplied with power (via its power jack) from an adapter or a power supply capable of supplying enough current for all the FX1's being used – phantom power will be distributed via the interconnecting MIDI cables. **This option requires that Cable #1 (in the above diagram) has its phantom power pins disconnected !!!**

Option #2 – The master FX1 is supplied with phantom power via its connection (Cable #1) to the guitar router/switcher and one of the slaved FX1's is supplied with power (via its power jack) from an adapter or power supply capable of supplying enough current for all the slaved FX1's being used – phantom power will be distributed via the interconnecting MIDI cables. **This option requires that Cable #2 and Cable #n (loop back cable from the last slaved FX1 to the master FX1) have their phantom power pins disconnected !!!**

# 19. Master / Slave Loop (Cont'd)

## 19.1.2 Master/Slave Cable Details

The maximum cable length allowed (for each cable in the Master/Slave Connections diagram above) by the MIDI specification is 50ft., but the shorter the better because cable quality will determine the maximum length usable.

Cable #1 – The end of this cable that plugs into the TO RACK jack on the FX1 should be a Neutrik 5-pin XLR female plug (p/n NC5FX). The other end of this cable is determined by the guitar router/switcher being used, it can be a regular MIDI plug or an XLR plug or who knows what... The pinout of the TO RACK jack on the FX1 is as follows:

[1] 9Vac [2] n/c [3] 9Vac [4] MIDI Out Pin#4 [5] MIDI Out Pin #5 [S] Shield/Ground

Cable #2 – This cable should be a standard 5-pin MIDI cable with all five pins connected (as follows) unless phantom power pins [1] and [3] need to be disconnected as per Option #2 of the Master/Slave Loop.

[1] to [1] Phantom Pwr.  
[2] to [2] Shield/Ground  
[3] to [3] Phantom Pwr.  
[4] to [4] MIDI Signal #4  
[5] to [5] MIDI Signal #5

Cable conductor for [2] should be the bare Drain Wire.  
Cable conductors for [1] and [3] should be a twisted pair.  
Cable conductors for [4] and [5] should be a twisted pair.

Cable #3 – Same as Cable #2, but with all five pins connected at all times.

Cable #4 (and on for more slaves) – Same as Cable #2, but with all five pins connected at all times.

Cable #n – Same as Cable #2 with phantom power pins [1] & [3] connected or disconnected as per Option #1 or #2.

## 19.1.3 Power Supply/Adapter Details

The power adapter shipped with the FX1 is capable of supplying 9Vac @ 1000mA which is more than enough to power two FX1's – and if implementing Option #2 (above) a Master/Slave Loop of three FX1's can be realized with the included adapter. Please contact Axess Electronics if a more powerful adapter is required.

## 19.1.4 A Few Things To Remember

The pedals/switches connected to the expression pedal ports on every slaved FX1 must be calibrated to ensure the slaved FX1's act exactly like the master. This is the only editing/programming required on a slaved FX1.

The letter "V" will flash periodically at the 3<sup>rd</sup> display character location (c) to indicate the Slave (SLAV) Operating Mode is active. Other than the operating mode indicator, every slaved FX1 will act like it's the master FX1.

The FX1 does not transmit or receive any Master/Slave Loop information via its MIDI jacks when it is in the Edit Mode. So if an FX1 connected in the Master/Slave Loop enters the Edit Mode, or if a MIDI cable is disconnected or damaged, the following message will be shown on the display of every slaved FX1, indicating that the Master/Slave Loop is broken... As such, the guitar technician or someone else capable of troubleshooting and fixing the Master/Slave Loop during a show/performance should use a slaved FX1, while the guitarist uses the master.

a b c d e f g h i j k l m n o p



# 20. Factory Default Settings

- Receive MIDI Channel = NO
- Program Change Starting Number (MIDI Channels 01 to 16) = 001
- Internal Control Changes (24 of them):
  - Control Change Number = OFF and MIDI Channel = \*\*
- S1 – S24 Control & Program Changes (24 of them):
  - c1 Control Change Number = OFF and MIDI Channel = \*\*
  - c2 Control Change Number = OFF and MIDI Channel = \*\*
  - p<sup>on</sup> Program Change Number = OFF and MIDI Channel = \*\*
  - p<sup>off</sup> Program Change Number = OFF and MIDI Channel = \*\*
- XP1 – XP4 Global Settings (4 of them):
  - MIDI Channel = \*\*
  - Minimum Value = 000
  - Maximum Value = 127
  - Beginning Value = 127
  - Control Change Number = OFF
- S1 – S12 Custom Hex/MIDI Message (12 of them):
  - Byte 1 to Byte 16 (for ON and OFF) = FF
- Setlist Names (10 of them): Rename Set0 - Rename Set9
- Songs Names (99 of them): Rename Sng01 - Rename Sng99
- MIDI Channel Names (16 of them): Rename Chan01 - Rename Chan16
- Internal Control Change Names (24 of them): Rename Icc01 - Rename Icc24
- Instant Access Switches Names (24 of them): Rename IASw01 - Rename IASw24
- Preset Names (126 of them plus the Global Preset):
  - Global Preset = Global Preset
  - Preset 1 (Bank 01 Preset 1) = Preset No.001
  - || || || || || ||
  - Preset 126 (Bank 21 Preset 6) = Preset No.126
- Program Change Messages (all presets and 16 per preset) = OFF
- Instant Access Switch ON/OFF Status (all presets and 24 per preset) = OFF
- Internal Control Change ON/OFF Status (all presets and 24 per preset) = OFF
- XP1 – XP4 Preset Settings (all presets and 4 per preset):
  - MIDI Channel = \*\*
  - Minimum Value = 000
  - Maximum Value = 127
  - Beginning Value = 127
  - Control Change Number = GLO
- Preset Custom Hex/MIDI Message (all presets and 1 per preset):
  - Byte 1 to Byte 16 = FF
- Song Create/Edit:
  - Preset 0 to 6 for all 99 songs = B01 P1
- Setlist Create/Edit:
  - Song 01 to 50 for all 10 setlists = Sng01
- Operating Mode = PRST
- Global Preset Availability:
  - SS = Y
  - PR = Y
- S1 – S12 Switch Link:
  - Link A & B (all switches) = x
- XP1 – XP4 Port Type (4 of them) = LinVP
- Instant Access Switch Type (24 of them) = LTCH



# 21. MIDI Implementation Chart

| Function                             |   | Transmitted      | Recognized       | Remarks   |
|--------------------------------------|---|------------------|------------------|---|
| <b>Basic Channel</b>                 | Default Changed   | None<br>1 – 16   | None<br>1 – 16   | FX1 is shipped with all its MIDI messages turned off, changed settings can be saved in EEPROM memory.   |
| <b>Mode</b>                          | Default<br>Altered<br>Messages                                  | X<br>X<br>X      | X<br>X<br>X      |   |
| <b>Note Number</b>                   | True Voice  | X                | X                |   |
| <b>Velocity</b>                      | Note On<br>Note Off   | X<br>X           | X<br>X           |   |
| <b>After Touch</b>                   | Key's<br>Channel  | X<br>X           | X<br>X           |   |
| <b>Pitch Bend</b>                    |   | X                | X                |   |
| <b>Control Change <sup>(1)</sup></b> |   | O                | O                | Control Change 32hex with Control Value 1 to 50 or 99 selects song 1 to 50 or 99 depending on the Operating Mode (SETn or SONG).  |
| <b>Program Change <sup>(2)</sup></b> | True Number   | O                | O                | Program Changes can be displayed with a starting number of 0 (to 127) or 1 (to 128).<br><br>Program Changes 1 to 7 select presets 1 to 6 and the Global Preset (within the current song) and Program Changes 1 to 127 select presets 1 to 126 and the Global Preset (bank 01-21). |
| <b>System Exclusive</b>              |   | O                | O                | User data dump and load, master/slave messages and firmware updates.  |
| <b>System Common</b>                 | Song Select<br>Song Position<br>Tune Request                    | X<br>X<br>X      | X<br>X<br>X      |   |
| <b>System Real-Time</b>              | Clock<br>Commands   | X<br>X           | X<br>X           |   |
| <b>Auxiliary Messages</b>            | Local On/Off<br>All Notes Off<br>System Reset<br>Active Sensing | X<br>X<br>X<br>O | X<br>X<br>X<br>O |   |

O : Yes      X : No

- Each instant access switch can send two control change messages and each internal control change can send one control change message. The control value for these control change messages is fixed at 0 = off & 127 = on.
- Each instant access switch can send two program change messages, one when the switch is on and the other when the switch is off. Each preset can also send up to sixteen program change messages, one on each MIDI channel.

**Please Note:** Each instant access switch can send two custom 16 byte hex/MIDI messages (one when the switch is on and the other when the switch is off) and each preset can send one custom 16 byte hex/MIDI message. So though it may not be indicated in the above chart, the FX1 can transmit more messages than just those shown with an O.

# 22. Controlling Multiple GCX's

Controlling multiple Digital Music Corp. GCX audio switchers with the FX1 MIDI Footcontroller is a breeze and will not require you to change GCX software EPROM's... When multiple GCX's are used in a single guitar rig, they need to be told which GCX they are - either GCX#1, GCX#2, GCX#3 or GCX#4. The DMC Ground Control (old version) and the Ground Control Pro do this "behind the scenes" with a short MIDI sysex message. To enable the FX1 to do the same, simply create the following custom hex/MIDI message;

(1<sup>st</sup> byte) F0 00 00 07 YY 08 XX F7 (8<sup>th</sup>/last byte)

for one of the (S1 – S12) instant access switches, either when the switch is ON or OFF, both is not necessary. Make sure that the instant access switch you've selected is NOT setup as a hold (HOLD) type switch or is "linked" with other instant access switches as per Section 16.2 : S1 – S12 Switch Link.

Hopefully you've noticed the XX and the YY in the above MIDI sysex message, these two variables will allow you to further dictate how the GCX's will respond/operate in a guitar rig.

The first variable, XX, tells all the GCX's which MIDI channel they should operate on (which must match the MIDI channel that the MIDI control change messages listed below will be transmitted on by the FX1).

Therefore, if XX = 01 all the GCX's will operate on MIDI channel #1  
02 all the GCX's will operate on MIDI channel #2  
03 all the GCX's will operate on MIDI channel #3  
04 all the GCX's will operate on MIDI channel #4  
05 all the GCX's will operate on MIDI channel #5  
06 all the GCX's will operate on MIDI channel #6  
07 all the GCX's will operate on MIDI channel #7  
08 all the GCX's will operate on MIDI channel #8  
09 all the GCX's will operate on MIDI channel #9  
0A all the GCX's will operate on MIDI channel #10  
0B all the GCX's will operate on MIDI channel #11  
0C all the GCX's will operate on MIDI channel #12  
0D all the GCX's will operate on MIDI channel #13  
0E all the GCX's will operate on MIDI channel #14  
0F all the GCX's will operate on MIDI channel #15  
10 all the GCX's will operate on MIDI channel #16

The second variable, YY, tells the GCX physically connected to the FX1 (via the regular 5-pin MIDI OUT jack or via the heavy-duty TO RACK jack > GCX MIDI/PEDAL IN jack) which GCX it should be, then that GCX will tell the next one which it should be, and so on... For example, if YY is 01, then the GCX physically connected to the FX1 will automatically be GCX#1, it will tell the next GCX to be GCX#2, which will in turn tell the next one to be GCX#3, which will then tell the next/last GCX to be GCX#4.

Therefore, if YY = 01 the GCX physically connected to the FX1 will be GCX#1  
02 the GCX physically connected to the FX1 will be GCX#2  
03 the GCX physically connected to the FX1 will be GCX#3  
04 the GCX physically connected to the FX1 will be GCX#4

The GCX loops are activated by MIDI control change messages which should all be on the same MIDI channel. The default MIDI channel that the GCX's use (when no MIDI sysex message is sent to them) is MIDI channel #16, but if/when using the above MIDI sysex message, a MIDI channel MUST be specified... Below is a list of the MIDI control change messages that GCX#1 through to GCX#4 must receive in order to turn their loops on and off.

|       |                                      |   |
|-------|--------------------------------------|---|
| GCX#1 | Latching = (Loop 1) 80 – 87 (Loop 8) | Momentary = (Loop 1) 104 – 111 (Loop 8) |
| GCX#2 | Latching = (Loop 1) 88 – 95 (Loop 8) | Momentary = (Loop 1) 112 – 119 (Loop 8) |
| GCX#3 | Latching = (Loop 1) 64 – 71 (Loop 8) | Momentary = (Loop 1) 96 – 103 (Loop 8)  |
| GCX#4 | Latching = (Loop 1) 56 – 63 (Loop 8) | Momentary = (Loop 1) 72 – 79 (Loop 8)   |

# 23. User Manual Revision History

## Rev. 1 to Rev. 3

- Added this section and Section 22 : Controlling Multiple DMC GCX's.
- Added a note to Section 5 : Quick Start (Item 10) about labeling the instant access switches.
- Updated Section 6 : Display with what is shown on the display when in the SONGS and SETn operating modes.
- Added a picture of an expanded FX1 to Section 8.1.10 : Expander.
- Added a note to the end of Section 12.4 : Internal Control Changes describing what they are.
- Updated Section 12.5 : XP1 – XP4 Global Settings and Section 14.6 : XP1 – XP4 Preset Settings with information about how the NAMES switch can be pressed to display the name assigned to the MIDI channel shown and how entering 444 for the BegValu (for the Global Settings only) will cause the FX1 to transmit the MIDI data corresponding to the actual expression pedal position when a preset is first selected.
- Replaced the following text (crossed out below) from Section 12.6 : S1 – S12 Custom Hex/MIDI Message and Section 14.7 : Preset Custom Hex/MIDI Message with instructions to download (from our website) the MIDI/Hex Calculator (PC version only) or the FX1 Editor (for the Mac/PC), which includes a built-in calculator...

### **!!! ATTENTION !!!**

~~Use of this feature on the FX1 is NOT recommended for MIDI beginners — please proceed with CAUTION and ONLY if you REALLY know what you are doing !!!~~

- Updated Section 16.4 : XP1 – XP4 Port Type with information on how to select different volume/expression pedals; linear or audio/logarithmic.
- Added Section 16.7.1 : Remote Data Dump/Load.
- Added a note after the first paragraph in Section 16.9 : Firmware Version & Update to visit our website to see what the current firmware version is and how to get an update...
- Updated the first paragraph of Section 16.9.1 : Updating The FX1 Firmware with Axess' recommendation for Mac/PC MIDI interfaces (external USB made by [www.m-audio.com](http://www.m-audio.com) ).
- Updated the last sentence in Section 19.1.4 : A Few Things To Remember (Master/Slave Loop) with how a guitar technician or someone else capable of troubleshooting and fixing the Master/Slave Loop during a show/performance should use a slaved FX1, while the guitarist uses the master (FX1).

## Rev. 3 to Rev. 4

- Updated Section 22 : Controlling Multiple DMC GCX's with additional information on how to change the MIDI channel that the GCX(s) will respond to MIDI control change messages on, as well as how to change the number of the first (and subsequent) GCX's from GCX#1 to GCX#2, GCX#3 or GCX#4.

